

# Forgotten Books

— [www.forgottenbooks.com](http://www.forgottenbooks.com) —

Copyright © 2016 FB &c Ltd.

All rights reserved. No part of this publication may be reproduced, distributed, or transmitted in any form or by any means, including photocopying, recording, or other electronic or mechanical methods, without the prior written permission of the publisher, except in the case of brief quotations embodied in critical reviews and certain other noncommercial uses permitted by copyright law.

# LESSONS IN HOROLOGY

BY

JULES GROSSMANN

Director of the Horological School, of Locle, Switzerland

AND

HERMANN GROSSMANN

Director of the Horological and Electro-Mechanical School, of Neuchatel, Switzerland

---

*AUTHORIZED TRANSLATION*

BY JAMES ALLAN, JR.

of Charleston, S. C.

Former Pupil of the Horological School, of Locle, Switzerland

---

VOLUME I

The Principles of Cosmography and Mechanics Relating to the Measurement of Time—Motive Force, Mainsprings, Trains, Gearings, etc.

*WITH OVER 100 ILLUSTRATIONS*

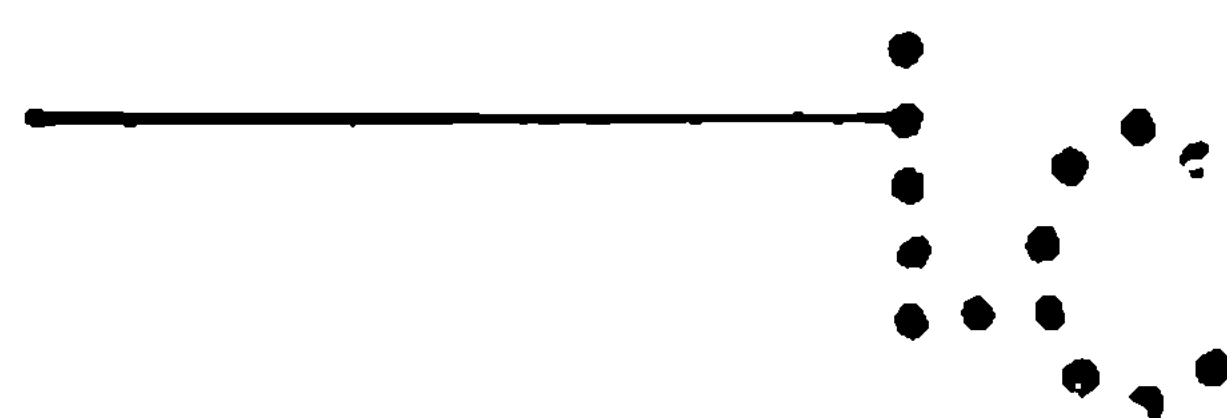

PUBLISHED BY

THE KEYSTONE

THE ORGAN OF THE JEWELRY AND OPTICAL TRADES  
19TH & BROWN STS., PHILADELPHIA, U.S.A.

1905

*All Rights Reserved*

|

TS 545  
G 87

LIBRARY of CONGRESS  
Two Copies Received  
**DEC 23 1905**  
Copyright Entry  
*Oct. 13, 1905*  
CLASS *a* XXc. No.  
*128616*  
COPY B.

---

COPYRIGHT, 1905, BY B. THORPE  
PUBLISHER OF THE KEYSTONE

---

2

## PREFACE BY THE AUTHORS

---

NO one ignores the fact that horology has attained a highly prominent position among the mechanical arts during the past quarter of a century, and that this fact is due to the rapid progress of science, industry and commerce in our epoch. If it sufficed formerly to know the time, approximately, and to make use of the indications of the sun dials, town clocks with single hands and other primitive instruments, modern times, with their multiplied requirements, have rapidly despoiled us of this ancient simplicity; they demand of us an exact marking of every instant, which only modern horary instruments permit us to attain.

The magnificent chronometers, whose superior timekeeping we admire to-day, are the product of the two-fold effort; first, of the theorist who, by his calculations, determines all the principles; then of the practical workman who faithfully follows these in the execution of his work.

In the period in which we live we cannot believe that we have yet attained the highest point of precision, but the results are already so brilliant that the mind now asks the question whether, before going farther into the technical domain, it would not be better first to bring to perfection the means of observation and of rating, which we now invariably employ with a degree of uncertainty. The magnificent instruments to which we have alluded are, moreover, still exceptions; they are very expensive as yet. So the most practical object of the technical study of horology is to approach, as nearly as possible in public timepieces, the results of the precision chronometer, at least so far as concerns the exactness of timekeeping. This purpose will surely be attained when horology, seconded by the admirable resources of mechanics, will entirely cease to be an art, too often empirical, and become a purely mechanical science.

It has long been believed that the theory of horology formed a science by itself, independent of general mechanics, and for a long time the watchmaker would not listen to anything about mechanics,



pretending that it was impossible to apply its data to the minute pieces which compose the mechanism of a pocket watch. This assertion was often apparently sustained by practical results, and frequently the purely mechanical data appeared as if they could not be applied to horology. But this conclusion, let us hasten to say, was false; for the reason that the mathematical formulas employed in mechanics often require less development than when they are applied to horology. In the first case many of the terms could be neglected which in the second would become important. We must not be astonished, either, if the results are not always what we seek. Let us take an example: Would one really dare to pretend that the laws of friction established by Coulomb, are inexact because it is very difficult in horology to separate friction proper from the influence of adhesion produced by the oil or other lubricating material? This second factor, which may often be omitted in large mechanics, becomes, we know, an important factor in horology. The work which we present to the English-speaking watchmakers is written by watchmakers and for watchmakers, and with the idea that horology and mechanics are twin sisters, and that the same laws and the same rules control both.

This work is the fruit of long experience in the domain of professional instruction in horological schools. We have endeavored to avoid speculations purely theoretical, as well as long descriptive explanations, which belong to books suited to the general public. If the solution of some problems cannot, in our estimation, be accomplished without the aid of higher mathematics, because of the precision required to attain the desired end, it must be noted that these questions can generally be put aside by those persons to whom the subtleties of mathematical analysis are unfamiliar.

It is sufficient then to recognize the fact that the calculations have been made to verify the deductions and to make use of the conclusions which may be drawn from them.

We are also obliged to grade the difficulties of calculation so that they are presented in proportion to the development of the mathematical knowledge of the persons who undertake the study, and we follow each problem with at least one numerical application. When it is possible we give also together with a complicated solution, another similar to it, but more simple.

Our plan comprises, first, a short introduction on the principles of cosmography and mechanics having relation to the measuring of

time. Then follow chapters which are devoted to the study of motive forces produced by the weight and the barrel spring, the calculations of trains and the theory of gearings. Then chapters on escapements, and finally the theory of adjusting and regulating forms an important part of the work, and will be treated with all the exactness due the subject. We will close this exposition of the theory by a treatise on the compensation of chronometers.

We hope that this work will contribute its share towards forming a generation of capable and educated horologists who can assist in the development of the fascinating industry of horology.

We owe a just tribute of appreciation to THE KEYSTONE, which has undertaken the publication of this work in the English language, and to James Allan, Jr., of Charleston, S. C., former pupil of the Locle Horological School, who has so well performed the work of translation.

JULES GROSSMANN,  
Locle, Switzerland.

HERMANN GROSSMANN,  
Neuchatel Switzerland.



# TABLE OF CONTENTS.

---

Paragraphs.	Pages.
<b>Preface</b> . . . . .	<b>3</b>

## INTRODUCTION.

### **I. General Principles of Cosmography Relating to Horology.**

<b>1</b> Principles of the measurement of time . . . . .	<b>9</b>
<b>3</b> Units of time. Sidereal day. Solar day . . . . .	<b>9</b>
<b>7</b> True time. Mean time . . . . .	<b>11</b>
<b>9</b> Laying out of a meridian line . . . . .	<b>12</b>
<b>13</b> Determination of the position of a point on the terrestrial sphere .	<b>14</b>

### **II. General Principles of Mechanics.**

<b>19</b> Forces . . . . .	<b>19</b>
<b>27</b> Law of inertia . . . . .	<b>20</b>
<b>28</b> Definition of mechanics . . . . .	<b>20</b>
<b>29</b> Motion . . . . .	<b>21</b>
<b>34</b> Rotary motion . . . . .	<b>22</b>
<b>35</b> Mass of a body . . . . .	<b>22</b>
<b>Work of a force</b> . . . . .	<b>23</b>
<b>37</b> Definition . . . . .	<b>23</b>
<b>38</b> Work of a force tangent to a wheel . . . . .	<b>24</b>
<b>39</b> Unit of work . . . . .	<b>24</b>
<b>40</b> Active power . . . . .	<b>24</b>
<b>Moment of a force</b> . . . . .	<b>25</b>
<b>43</b> Lever . . . . .	<b>26</b>
<b>Transmission of work in machines</b> . . . . .	<b>27</b>

---

## CHAPTER I.

### **General Functions of Clocks and Watches.**

<b>The oscillations of the pendulum and their relation to the motive force</b> . . . . .	<b>32</b>
--	-----------



Paragraphs.	Pages.
<b>The oscillations of the balance and their relation to the motive force . . . . .</b>	<b>35</b>
<b>Wheel-work.—Its purpose in the mechanism of clocks and watches .</b>	<b>37</b>
<b>Escapements . . . . .</b>	<b>39</b>

---

## CHAPTER II.

### Maintaining or Motive Forces.

<b>The weight as a motive force . . . . .</b>	<b>40</b>
<b>The barrel spring as a motive force . . . . .</b>	<b>43</b>
81 <b>Measurement of the force of a spring . . . . .</b>	<b>43</b>
<b>Theoretical study of the moment of a spring's force . . . . .</b>	<b>45</b>
86 <b>Coefficient of elasticity . . . . .</b>	<b>45</b>
91 <b>Variation of the coefficient of elasticity . . . . .</b>	<b>47</b>
92 <b>Values of the coefficient of elasticity <math>E</math> . . . . .</b>	<b>48</b>
93 <b>Limit of elasticity . . . . .</b>	<b>49</b>
94 <b>Moment of the elastic force of a spring subjected to a flexion . .</b>	<b>49</b>
100 <b>Inequality of the elastic force of the spring . . . . .</b>	<b>56</b>
104 <b>Length of the spring . . . . .</b>	<b>58</b>
<b>Development of a spring . . . . .</b>	<b>59</b>
111 <b>Diameter of the hub . . . . .</b>	<b>64</b>
<b>Work produced by spring . . . . .</b>	<b>66</b>
<b>The fusee . . . . .</b>	<b>67</b>
115 <b>Calculation of the variable radius of the fusee's helix . . . . .</b>	<b>69</b>
119 <b>Uniformity of the force of the spring in fusee watches . . . . .</b>	<b>74</b>
<b>Stop-work . . . . .</b>	<b>78</b>
128 <b>Geometrical construction of the Maltese cross stop-work . . . .</b>	<b>79</b>

---

## CHAPTER III.

### Wheel-Work.

129 <b>Purposes of wheel-work . . . . .</b>	<b>82</b>
<b>Calculations of trains . . . . .</b>	<b>82</b>
130 <b>Calculations of the number of turns . . . . .</b>	<b>82</b>
133 <b>Calculation of the number of oscillations of the balance . . . . .</b>	<b>84</b>
136 <b>Calculations of the numbers of teeth . . . . .</b>	<b>86</b>
<b>Problems relative to the preceding questions . . . . .</b>	<b>89</b>

Paragraphs.	Pages.
141-145 Numbers of turns . . . . .	89-90
146 Numbers of oscillations of the balance . . . . .	90
147-149 Numbers of teeth . . . . .	91-92
150 Numbers of teeth of the minute wheels. Description of this mechanism . . . . .	93
153-154 Numbers of teeth of an astronomical clock . . . . .	97-99
155-158 Numbers of teeth of lost mobiles . . . . .	100-102
159 Indicator of the development of the spring in fusee timepieces . .	102
160 Simple calendar watches . . . . .	104
161 Decimal watches . . . . .	106
164 Calculation of numbers comprising the teeth-ranges of the wheels of a watch with independent second hand . . . . .	109
168-169 Wheel-work of the stem-winding mechanism . . . . .	112-113
169 <i>a</i> Calculation of the train in a watch of the Roskopf type . . . .	114

---

CHAPTER IV.

**Gearings.**

170 Definition . . . . .	117
173 Practical examination of a gearing . . . . .	118
<b>First—Distance of the centers</b> . . . . .	119
176 Primitive radii . . . . .	119
179 Applications . . . . .	121
185 Calculation of the primitive radii . . . . .	125
193 Application of the theory of primitive radii to the escapements . .	129
<b>Second—Shape of the teeth and leaves</b> . . . . .	130
195 General study of the transmission of force in gearings . . . . .	130
<b>Determination of the forms of contact in gearings</b> . . . . .	136
209 First—Graphic method. Exterior gearing . . . . .	137
210 Interior gearing . . . . .	138
211 Second—Method of the envelopes . . . . .	140
219 Evolvents of circle gearings . . . . .	146
220 Third—Roller method . . . . .	148
221 Flank gearings . . . . .	150
226 <i>a</i> Determination of the profile of a tooth corresponding to a profile chosen arbitrarily . . . . .	154
226 <i>b</i> Gearings by the evolute of a circle . . . . .	155
<b>Teeth-range</b> . . . . .	156
<b>Third—Total diameters</b> . . . . .	159



Paragraphs.	Pages.
<b>Cycloid</b> . . . . .	159
235 Definition . . . . .	159
236 Drawing of the cycloid . . . . .	159
237 Drawing of the cycloid of a continuous movement . . . . .	160
238 Normal and tangent to the cycloid . . . . .	161
239 Evolute and radius of curvature of the cycloid . . . . .	161
240 Length of the cycloid . . . . .	162
<b>Epicycloid</b> . . . . .	163
241 Definition . . . . .	163
242 Drawing of the epicycloid . . . . .	163
243 Drawing of the epicycloid of a continuous movement . . . . .	164
244 To draw a normal, then a tangent to the epicycloid . . . . .	164
245 Evolute and radius of curvature of the epicycloid . . . . .	165
250 Length of the epicycloid . . . . .	169
251-253 Applications . . . . .	170-171
<b>Relation of the radius vector to the angle formed by the variable radius vector and the initial radius vector</b> . . . . .	171
Table showing the angle traversed by the pinion of several ordinary gearings during the contact of a tooth of the wheel with the leaf of this pinion . . . . .	175
<b>Calculation of the total radius of the wheel</b> . . . . .	176
<b>Form of the excess of the pinion leaf in a flank gearing</b> . . . . .	176
268 Radius of curvature of an ellipse . . . . .	181
270 Total radius of the pinion . . . . .	184
<b>Graphical construction of gearings</b> . . . . .	185
<b>Practical applications of the theory of gearings</b> . . . . .	188
276 The proportional compass and its use . . . . .	190
Table for using the proportional compass . . . . .	195
284 Verification of a proportional compass . . . . .	196
285 Determination of the distance of the centers of a gearing by means of the proportional compass and of a depthing tool . . . . .	196
286 The proportional compass and stem-winding wheel gearings . . . . .	197
286 Gearing of the crown wheel in the ratchet wheel . . . . .	198
287 Gearing of the winding pinion in the crown teeth of the contrate wheel . . . . .	199
288 Gearing of the sliding pinion and of the small setting wheel . . . . .	200
289 Gearings of the dial wheels . . . . .	201
<b>Various calculations relative to gearings</b> . . . . .	202
<b>Conical gearings</b> . . . . .	214
315 Form of the teeth . . . . .	216

Paragraphs.	Pages.
318 Construction of conical gearings . . . . .	218
<b>Defects which present themselves in these gearings</b> . . . . .	222
<b>Passive resistances in gearings</b> . . . . .	227
326 General ideas . . . . .	227
<b>Friction</b> . . . . .	228
330 The two kinds of friction . . . . .	229
332 Laws of friction . . . . .	229
333 Experimental determination of the force of friction . . . . .	230
335 Table of the coefficients of friction . . . . .	231
336 Work of friction . . . . .	232
337 Angle of friction . . . . .	233
<b>Calculation of the friction in gearings</b> . . . . .	234
339 Friction of the teeth ranges . . . . .	234
346 Friction before and after the line of centers . . . . .	238
348 1st. The wheel drives the pinion after the line of centers . . . . .	239
349 2d. The pinion drives the wheel before the line of centers . . . . .	241
350 3d. The wheel drives the pinion before the line of centers . . . . .	242
351 4th. The pinion drives the wheel after the line of centers . . . . .	244
352 Recapitulation of the preceding calculations . . . . .	244
<b>Calculations of the friction of pivots</b> . . . . .	245
354 Work absorbed by the friction of the plane surface of the shoulder of a pivot . . . . .	245
356 Work absorbed by the friction of the cylindrical surface of a pivot	247
357 Determination of the lateral pressure received by the pivots of the mobiles in a train . . . . .	247
<b>Influence of the oil</b> . . . . .	253
<b>Application of the theory of gearings</b> . . . . .	255
<b>Functions of the heart in chronographs</b> . . . . .	255





# LESSONS IN HOROLOGY



# LESSONS IN HOROLOGY.

---

## COURSE IN MECHANICS AS APPLIED TO CHRONOMETRY.

---

### **I. Introduction—General Principles of Cosmography Relating to Horology.**

**1. Principles of the measurement of time.** Cosmography is a science which has for its object the study of the different celestial phenomena as they are given to us by observation and calculation ; it comprehends also the study of the principles which are the basis of the measuring of time.

When one proposes to measure a length, surface, volume or weight of any kind one chooses arbitrarily a unit of length, surface, volume or weight with which one compares the object to be measured, noting exactly the number of times that this unit is contained therein.

When the purpose is to measure the intervals of time, it is no longer possible to make use of an analogical method. But to effect this operation one is obliged to determine the space traversed by a body animated with a uniform or periodically uniform motion (31). In the first place one concludes that the intervals of time are proportionate to the spaces traversed by the body considered.

**2.** It is necessary then to admit that all measurements of time must be deduced from the observation of a regular movement. Thus, formerly, one determined the fraction of time, more or less great, by the running of sand in the “hour glass,” or of water in the “clepsydra.” Now time is measured in clocks and in watches by the periodically uniform movement of the pendulum or balance wheel.

**3. Units of time. Sidereal day. Solar day.** For the determination of the unit of time it is necessary to choose the most uniform movement possible, a movement whose speed must be the same to-day, to-morrow, in a year or in an indefinitely prolonged period. Such a movement filling this condition absolutely, is the rotation of the earth on its axis ; no cause or effect whatever could increase or diminish it. We have positive proofs that this movement is the same to-day as it was in the time of Hipparchus, an ancient astronomer of the school of Alexandria who lived two centuries



before Jesus Christ. We can assure ourselves by the calculation of the eclipses, that the length of one of these rotations is the same to-day as in the time of that astronomer within  $\frac{1}{200}$  of a second. This movement has then been chosen because of its great regularity as the basis for the measuring of time.

The duration of a complete rotation is the unit, and is called a *day*.

4. In order to determine with exactitude the commencement and the end of this movement, it is necessary to choose a point of repose outside of the earth, and for this purpose a fixed star or the sun is taken. Let us remark that the result differs according as we take one or the other of these two points. The following demonstration will explain the reason.

5. We know that the earth not only turns on its axis, but that it has also a simultaneous movement around the sun. Let us take, then  $T$  and  $T'$ , Fig. 1, as the two positions which the earth occupies in its orbit at the commencement and at the end of one of its diurnal rotations. In the first of these positions,  $a$  is a point on its surface from which can be seen at this instant the center of the sun  $S$ , in an imaginary plane passing through the two poles and the point considered  $a$ , this plane is the *meridian plane*. At the end of a certain time, the earth has traveled in its orbit to the position  $T'$  and the point  $a$  arrives at  $a'$  in such a manner that the line  $T' a'$  is parallel to  $T a$ . The earth will then have accomplished one rotation on its axis and all of its parts will have, with relation to the fixed stars, the same positions that they had at  $T$ .

The time during which this rotation is accomplished is called a *sidereal day*.

But from the point  $a'$  in the position  $T'$  one could not see the sun in the meridian plane; in order that the observer placed at  $a'$  could perceive it anew in this plane, it would be necessary for the point  $a'$  to be removed to  $b$  in traversing the arc  $a' b$ . *The solar day*, that is to say, the time which elapses between two consecutive passages of the sun to the meridian plane is then longer than the sidereal day. In dividing the solar day into 24 hours, the hour into 60 minutes and the minutes into 60 seconds, the sidereal day counts only 23 hours, 56 minutes, 4.09 seconds; the sidereal day is then shorter than the solar day 3 minutes, 55.91 seconds.

If we divide, on the other hand, the sidereal day into 24 hours, the solar day will count 24 hours, 3 minutes, 56.55 seconds. This





**THIS PAGE IS LOCKED TO FREE MEMBERS**

Purchase full membership to immediately unlock this page

# DELVE INTO FANTASY, MAGIC, MYTHOLOGY & FOLKLORE

Forgotten Books'  
Full Membership gives  
access to 797,885 ancient  
and modern, fiction and  
non-fiction books.

**Continue**

\*Fair usage policy applies



its movement of translation is slowest. Another cause which still increases this irregularity is due to the fact that the axis of the earth is not perpendicular to the plane of the orbit that it traverses around the sun (plane of the ecliptic).

The length of the solar day can vary in 24 hours as much as 30 seconds, plus or minus. Thus the solar day with its diurnal variation of length does not fill at all the conditions desired for the measuring of time, the unit adopted must be of fixed value, so that our horological instruments, all based on a uniform movement, may follow their regular running without necessitating perpetual resetting. We fall then into a difficulty, since naturally the sun should measure the time for us, while in reality its unequal movement does not lend itself to this measuring. The difficulty has been adjusted as follows. We divide the total duration of the year by the number of solar days that it contains; the quotient will be a mean value, shorter than the solar days of greatest length and longer than the solar days of least duration. It will be, moreover, almost equal to certain days between them. This mean value is called *mean time*. We call, on the contrary, *true time* the direct interval of time elapsing between two successive passages of the sun across the meridian. The difference, plus or minus, between true time and mean time can amount to as much as 17 minutes.

**8. The equation of time** is the value that must be added to or subtracted from the true solar day to obtain the mean solar day. The year book of the Bureau of Longitudes announces each year in a calendar the result of the equation of time, and gives in a column entitled "Mean time at true noon" what a chronometer, regulated on mean time, should indicate at the exact moment of noon. The equation of time is nothing or almost that, four times a year—the 15th of April, 15th of June, 31st of August and 25th of December, while it attains its greatest value between the 10th and 12th of February and the first days of November.

**9. Laying out of a meridian line.** We already have an idea of the importance of the meridian plane in the determination of the length of a rotation of the earth on its axis.

Let us see now how we can proceed to establish the direction of a meridian line, that is to say, of the *trace* of the meridian plane on the surface of the earth. Among the several methods known let us choose the following, which recommends itself on account of its extreme simplicity, and which does not require instruments of precision.

On a horizontal plane, conveniently placed, we fix a vertical style; from its foot,  $O$ , Fig. 2, we describe on this plane several concentric circles of any size, such as  $m n$ ,  $m' n'$ , etc. Let us mark on these circumferences the points  $A$ ,  $B$ ,  $C$ , etc., where the extremity of the shadow of the pin reaches before midday. In the afternoon renew the operation by indicating in the same manner the points  $A'$ ,  $B'$ ,  $C'$ , etc. We connect the points marked on the same circumference by a straight line, and we obtain thus as many straight lines as circles, and they are parallel to each other. The perpendicular laid off from the center  $O$ , on these straight lines, will be

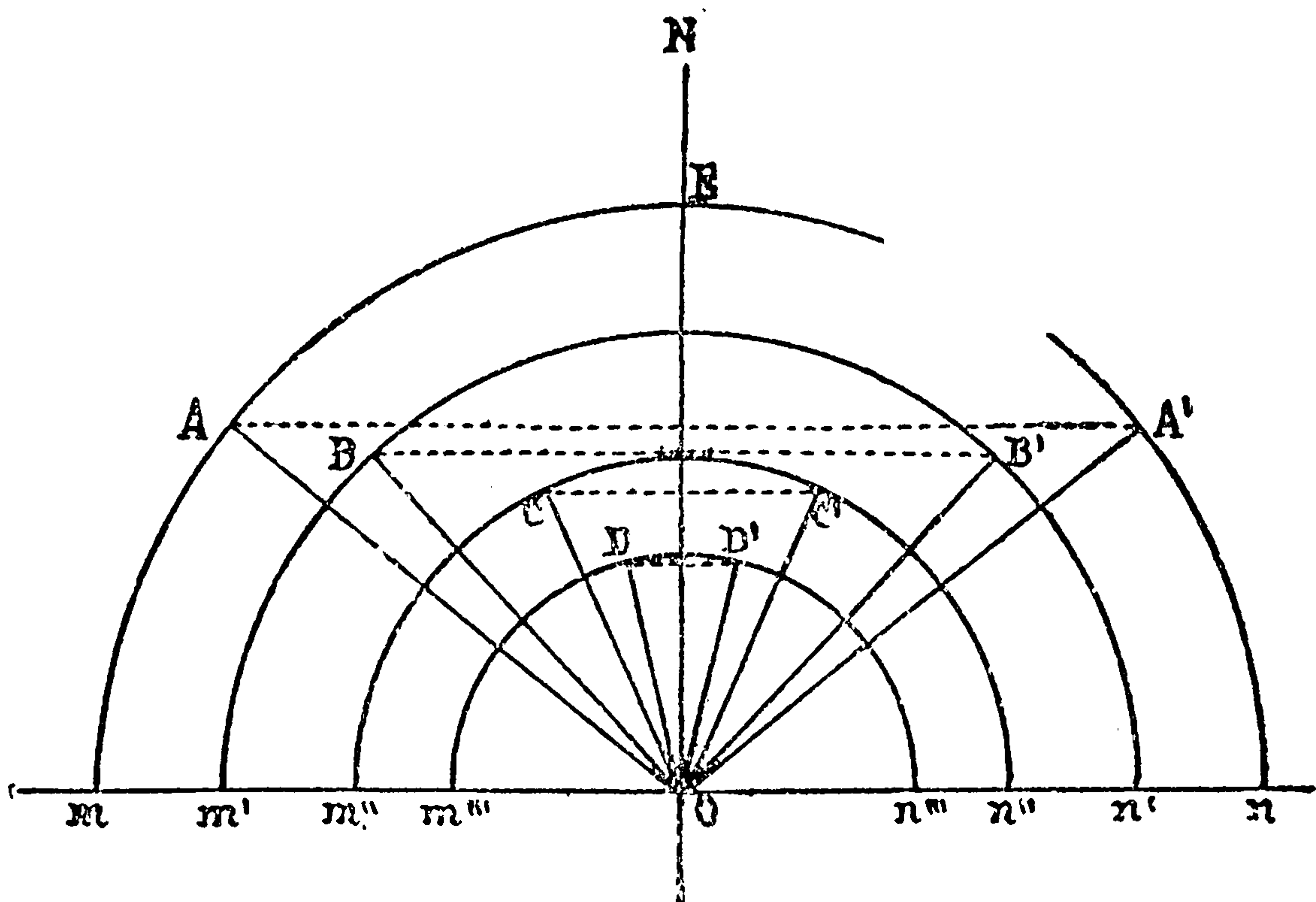

Fig. 2

the meridian line sought. Since the shadow cast by such a style is never very distinct, we will reach a greater accuracy by finishing the extremity of the pin with a metallic plate, in which we pierce a fine hole. We indicate then the center of the image of the sun on each of the circumferences, as previously done. In the above construction a single arc sufficed, but it is preferable to employ several which mutually control each other, the middle of the straight lines,  $AA'$ ,  $BB'$ ,  $CC'$ , etc., should be found with the center  $O$  on the same perpendicular  $ON$ .

10. When the middle of the small image of the sun is found on the meridian it is nearest the foot of the style and consequently the sun is at its greatest height; it is then exactly midday. To obtain the mean hour we must consult a table of equations and add or



subtract, according to the season of the year, the correction indicated for this day. Generally, as we have said, these tables indicate the "mean time at noon," thus for the 17th of November, 1893, we find for example indicated :

Mean time at noon 11 h. 45 m. 10 s. the clock or watch should then mark 11 hours, 45 minutes and 10 seconds when the middle of the small image of the sun is projected on the meridian line.

**11. The Meridian Glass** employed in the observatories is nothing else than a meridian line determined with the greatest exactness. It is generally a glass of sufficiently large size which can only move in the meridian plane, and is divided by it into two symmetrical parts. It is supported on two immovable pillars by means of trunnions, which permit it to take all the positions possible around its axis of rotation. It can then be used to observe the passage on the meridian of all the visible stars above the horizon. The sensitiveness of the instrument is moreover augmented by the magnifying power of the glasses employed.

Since such an instrument cannot be transported, we have recourse to other instruments in order to determine the hour at any locality, on the sea for example. The one generally used is the *sextant*, but its employment is complicated.

**12.** If the mean hour is known, and it is only a question of maintaining it, the apparent motion of the fixed stars is easily used for this purpose ; in short, since these stars return to the same position at the end of 24 sidereal hours, it is sufficient to place a level of any sort, but fixed and invariable, in the direction of a star ; the next day at the same hour (solar time), less 3 minutes, 55.91 seconds this same star would present itself anew before the level. The fixed stars afford the greatest facility for the control of the running of watches and clocks.

**13. Determination of the position of a point on the terrestrial sphere.** Since marine chronometers are among the instruments which are used to determine the position of any point on the surface of the earth, especially that of a vessel at sea, each watchmaker should inform himself of the part that these instruments play in such observations, on which depend the security of the ship and that of the beings which it transports.

**14.** In order to represent the position of a point on the surface of a sphere, such as the earth, we suppose described on this sphere two great circles, one, passing through the two poles,

is called the *meridian circle*; the other, perpendicular to the first, is the *equator*. This last is consequently perpendicular to the terrestrial axis, and at all points equally distant from the poles. Each of these circles is divided into 360 degrees. The divisions marked on the meridian circle commence at the equator, and are reckoned north and south to the poles, therefore from 0 to 90 degrees. These degrees are called *degrees of latitude*.

Since we can imagine an infinite number of meridians passing through the poles, the point  $\sigma$  can be placed arbitrarily, that is to say, the first meridian at whatever place it suits best. Thus England has chosen as the starting point the meridian which passes through the Observatory at Greenwich, in the neighborhood of London; France has made choice of the one which passes through the Observatory of Paris, and other nations have made their first meridian pass through the Isle of Fer.

The degrees reckoned on the equator are called *degrees of longitude*, and are reckoned both to the east and to the west of the first meridian, from 0 to 180 degrees.

By imagining circles parallel to the equator passing through each division of the meridian circle, and meridian circles passing through each division of the circle of the equator, the *latitude* of a point will be then the distance in degrees from the parallel circle passing through this place to the equator, and its *longitude* will be the distance in degrees from the meridian of this place to the meridian chosen as the starting point.

These values constitute what are called the *geographical coördinates* of a point, and the position of this point on the terrestrial globe will be perfectly determined when we know its longitude *east* or *west*, and its latitude *north* or *south*. Thus we would say that the geographical coördinates of the city of Neuchatel, in Switzerland, are

46° 59' 15" north latitude,  
4° 35' 54" longitude, east of the meridian of Paris.

**15.** In order to determine practically the latitude of a point  $A$ , Fig. 3, the simplest manner is to measure the angle formed by a horizontal line  $AB$ , and by the line  $AC$  ending in the Polar star. In short, the fixed stars being prodigiously removed from the earth, which is but a point in relation to this enormous distance, we can say without appreciable error that all the straight lines



drawn from the earth to the Polar star are parallel to each other, which moreover conforms to experience.

Since the Polar star is found almost exactly on the prolongation of the axis of the earth, the straight line that we imagine drawn from any point on the globe to this star is parallel to the axis. We can then say that the latitude of such a place as  $A$ , which is in reality the angle  $A O E$ , is represented by the angle  $B A C$ :

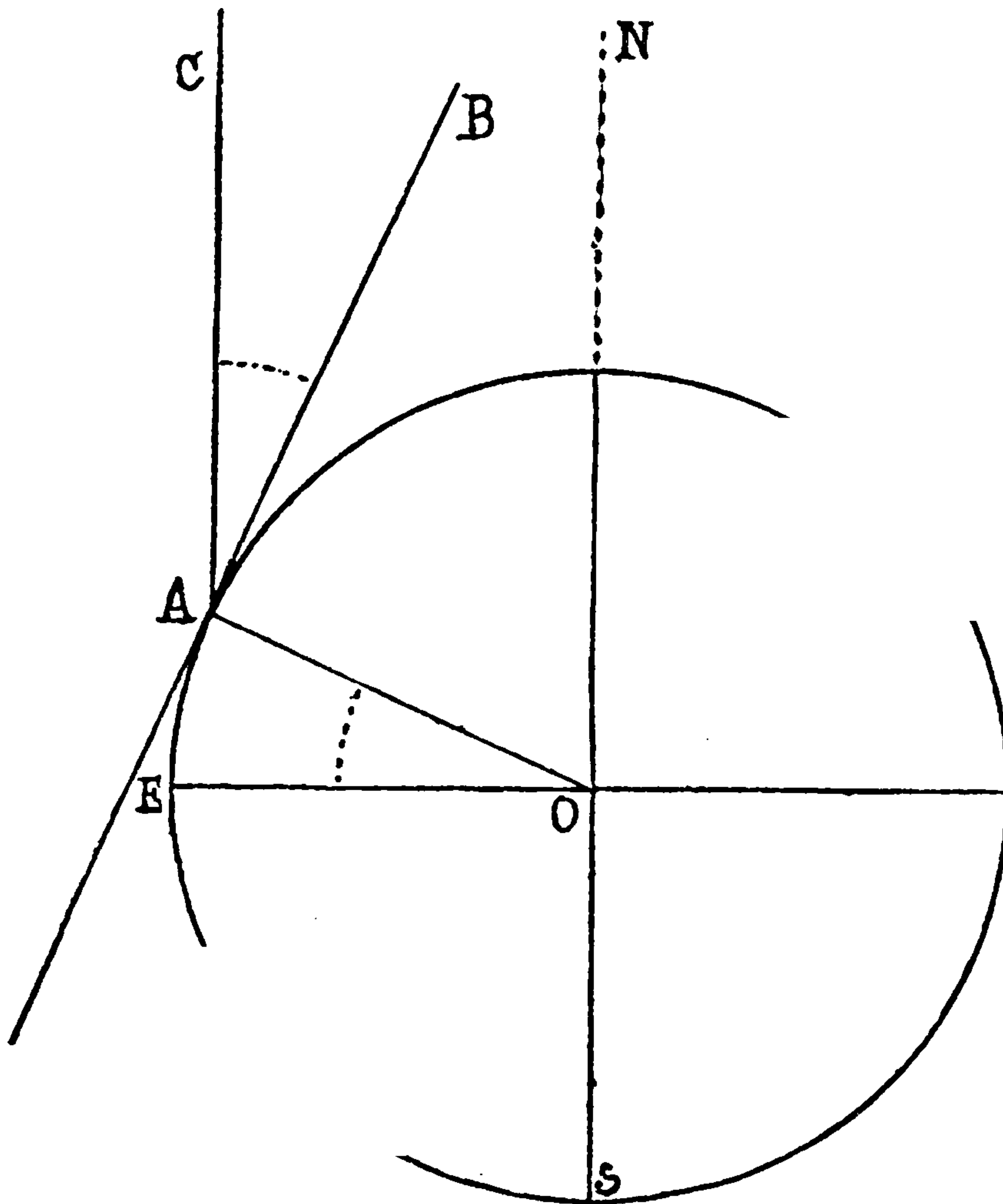

Fig. 3

practically the angles  $A O E$ , and  $B A C$  are equal by having their sides perpendicular each to each. We see then that the latitude of a place is equal to the height of the pole above the horizon. In order to determine it with greater exactness it would still be necessary to take note of the distance of the Polar star from the axis and of the refraction of the luminous rays.

16. The means employed in order to determine the longitude by direct observations are scarcely practicable, therefore we use in preference a marine chronometer whose daily rate is known.

Let us suppose that a ship is one day at a certain point, which we will designate by  $A$ , that we have made the observation of the

passage of the sun across the meridian, and that we have noted the advance or the delay of the hour marked by the chronometer at this instant. Let us call  $C_0$  the number of hours, minutes and seconds shown by the watch at the exact moment of the passage of the sun across the meridian. One or several days later, we repeat this observation and we find, let us suppose, a new correction that we will designate by  $C$ .

The difference between  $C_0$  and  $C$ , divided by four minutes, will give us the number of degrees that the ship has advanced in one or the other direction of longitude.

In short, since the earth takes twenty-four hours to accomplish a complete rotation of 360 degrees, it would require  $\frac{24 \text{ h.}}{360^\circ}$  which is four minutes to cover one degree. We understand that it would still be necessary to take account in the calculation of the daily rate of the chronometer; this value is an average based on a great number of former observations. All the accuracy of this method depends then on the absolute regularity of the daily rate of the marine timepieces.

The values  $C_0$  and  $C$  are algebraic values, that is to say of quantities preceded by positive signs (+) or negative signs (—), since the chronometer can be behind or in advance at the time of the passage of the sun across the meridian.

Let us determine now which of these signs belongs to the advance of the timepiece and which will designate its retardation.

In the first place, it is evident that this choice is arbitrary; thus, at the Observatory of Greenwich, they have adopted the negative sign for the retardation and the positive sign for the advance. This choice seems at first sufficiently normal, but at Neuchatel one is placed at a different point of view. When the chronometer is slow at the passage of the sun, in order to find the true time we must add to the hour indicated by it the correction  $C$ ; this value should then be preceded by the positive sign, while when the chronometer is fast at the passage of the sun we must subtract the correction  $C$  in order to obtain the correct time; in this case then, this value should receive the negative sign. It is this manner of viewing the matter which has led, at the Observatory of Neuchatel, to the adoption of the sign + for slow, and — for the advance of the chronometer

17. As we have said that a chronometer never follows exactly the mean time, its daily rate therefore should be determined in an



observatory ; because this daily rate must be reckoned with in the determination of the longitudes. Let us designate by  $A$  this mean value, and since it can be fast or slow let us precede it by the negative or positive sign. The chronometer is observed at the moment of the passage of the sun across the meridian ; this observation giving the true time it will be necessary to deduct the mean time from it. Let us call  $B$  the difference between the mean time and the true time (equation of time) and let us determine the sign of this last value.

Since it is desired to bring back the correction  $C$  to the mean time we will argue that, if the mean time at noon is fast, the true time is slower than the mean time and the value  $B$  should receive the sign  $+$ , on the other hand, if the mean time is slower than the true time,  $B$  would receive the sign  $-$ .

Let suppose now that a ship leaves a seaport whose longitude is  $E_0$  degrees west of Paris. The day of departure we have observed the passage of the sun and obtained a correction  $C_0$ . The correction  $C'_0$  of the chronometer on the mean time will be for this day

$$C'_0 = C_0 + B_0$$

at the end of  $N$  days we repeat the observation of the passage of the sun, and we will obtain a correction  $C$  between the time of the chronometer and the true time ; the correction  $C'$  between the time of the chronometer and the mean time will be expressed by

$$C' = C + B.$$

The difference  $D$  between the time of departure and the time of the place where the vessel now is will be

$$D = (C + B) - (C_0 + B_0) - NA.$$

Reducing this value to minutes, we will have the longitude  $E$  in degrees by the division :

$$E = \frac{(C + B) - (C_0 + B_0) - NA}{4} + E_0$$

18. Let us take a numerical example.

The longitude of Havre west of the meridian of Paris being  $2^\circ 13' 45''$ , let us imagine a vessel leaving this port November 2, 1893. The time shown this day by a marine chronometer at the moment of the passage of the sun across the meridian is 11 h.





**THIS PAGE IS LOCKED TO FREE MEMBERS**

Purchase full membership to immediately unlock this page



# HISTORY

Tens of thousands of important historical sources, many previously unobtainable, are now available for the first time with a Forgotten Books Full Membership.

Unlimited Access  
\$8.99/month

**Continue**

\*Fair usage policy applies



number of kilogrammes. Let us suppose, for instance, a cord fastened to the car and passing over a fixed pulley placed before the vehicle ; if we suspend weights to the free end of the cord and increase them until the car commences to move, the total of the weight will give us the measure of the effort put forth by the man in order to produce the movement desired.

**21.** As a general rule, we give the name of *motive force* to any power which puts a body in motion, and, on the other hand, that of *resistant force* to every active or passive force in opposition to this movement.

**22.** Without being able to define the nature of forces, the sensations which they invariably produce in us give us immediately an idea of their *intensity* and of their *direction*.

The directions of forces are represented by the straight lines along which they tend to move the body to which they are applied. It is suitable to represent their intensity by lengths which are proportionate, the result is that we can submit forces to the same mathematical processes as any other quantities.

**23.** The **point of application** of a force is that part of a body on which it acts directly in order to change the state of motion or of rest of this body.

**24.** The **line of direction** of a force is that along which it tends to make its point of application advance.

**25.** A force capable of replacing by itself alone a system of forces acting on a body is called the *resultant* of all these forces. These last are called the *components* of the only force able to replace them.

**26.** The **trajectory** is a line which the movable point follows. The movement is called *rectilinear* or *curvilinear*, according as the trajectory is a straight line or a curve.

**27. Law of inertia.** Experience has established a law to which all bodies are subject and which constitutes a fundamental principle of mechanics. This law known under the name of "*principle of inertia*" can be defined as follows :

*A material body cannot put itself in motion if it is at rest and, reciprocally, if it is in motion it cannot of itself modify its movement.*

**28. Definition of mechanics.** Mechanics is the science of forces and their effects. Its object is to find the relations of the forces which affect a body or a system of bodies causing this body or this system to take a certain movement in space. Reciprocally being

given a body or a system of bodies, to find the motion that this body or system of bodies will take in space under the action of given forces.

This general problem comprehends the one in which the forces make no change in the state of the body or of the system, a particular case in which we say that the forces are *in equilibrium*. Thence comes the division of mechanics into *statics* or the science of equilibrium and *dynamics* or the science of motion. We can still study the movements of bodies, considering only their direction, intensity and duration, in leaving out the matter of which the bodies are formed and the forces which produce or modify these movements. This study forms a part of mechanics to which is given the name of *kinematics*, which can also be called geometric mechanics.

**29. Motion.** Motion is *uniform*, when equal distances are traversed in equal times.

We call the space traversed in the unit of time *velocity*, we will have then, designating velocity by  $v$ , space by  $s$  and time by  $t$ ,

$$s = t v$$

whence we have

$$v = \frac{s}{t} \text{ and } t = \frac{s}{v}$$

**30.** The motion is called *variable* if the spaces traversed in any equal times are unequal ; that is to say, when the speed of the body is not constant during the entire duration of the motion.

**31.** When a moving body traverses certain equal distances in equal times, without fulfilling the same conditions for parts of these distances, we say that the motion is *periodically uniform*. Such are, for example, the motion of the earth around the sun and the vibratory motion of a pendulum in small amplitudes.

**32.** The motion is *uniformly variable* when the velocity of the moving body varies equal quantities in equal times.

*The acceleration* is then the quantity which the velocity varies during the unit of time.

If in uniformly variable motion, the velocity increases the acceleration is positive and we say that the motion is uniformly accelerated.

If the velocity diminishes, the acceleration is then negative and the motion is said to be *uniformly retarded*.

**33.** The motion of a body which falls by the action of its *weight* is uniformly accelerated. In this case we designate the acceleration due to the weight by the letter  $g$ ; this value is constant



for the same place and in our regions  $g = 9.8088$  m. This value represents twice the distance traversed during the first second by a body falling freely and without initial velocity.

**34. Rotary motion.** A solid is animated with a movement of rotation on an axis when each of its points describes a circumference whose plane is perpendicular to the axis and whose center is found on this axis. In this movement any two points of the body, describe, in the same time, similar arcs, that is to say, of the same number of degrees; but the lengths of these arcs are different and should be proportionate to their distances from the axis. Let  $e$  and  $e'$  be the arcs traversed in the same time by two points  $m$  and  $m'$  (Fig. 4) situated at the distances  $r$  and  $r'$  from the axis of rotation, we would have

$$\frac{e}{e'} = \frac{r}{r'}.$$

The movement of rotation is uniform if, in equal times, a point of the body describes always equal arcs.

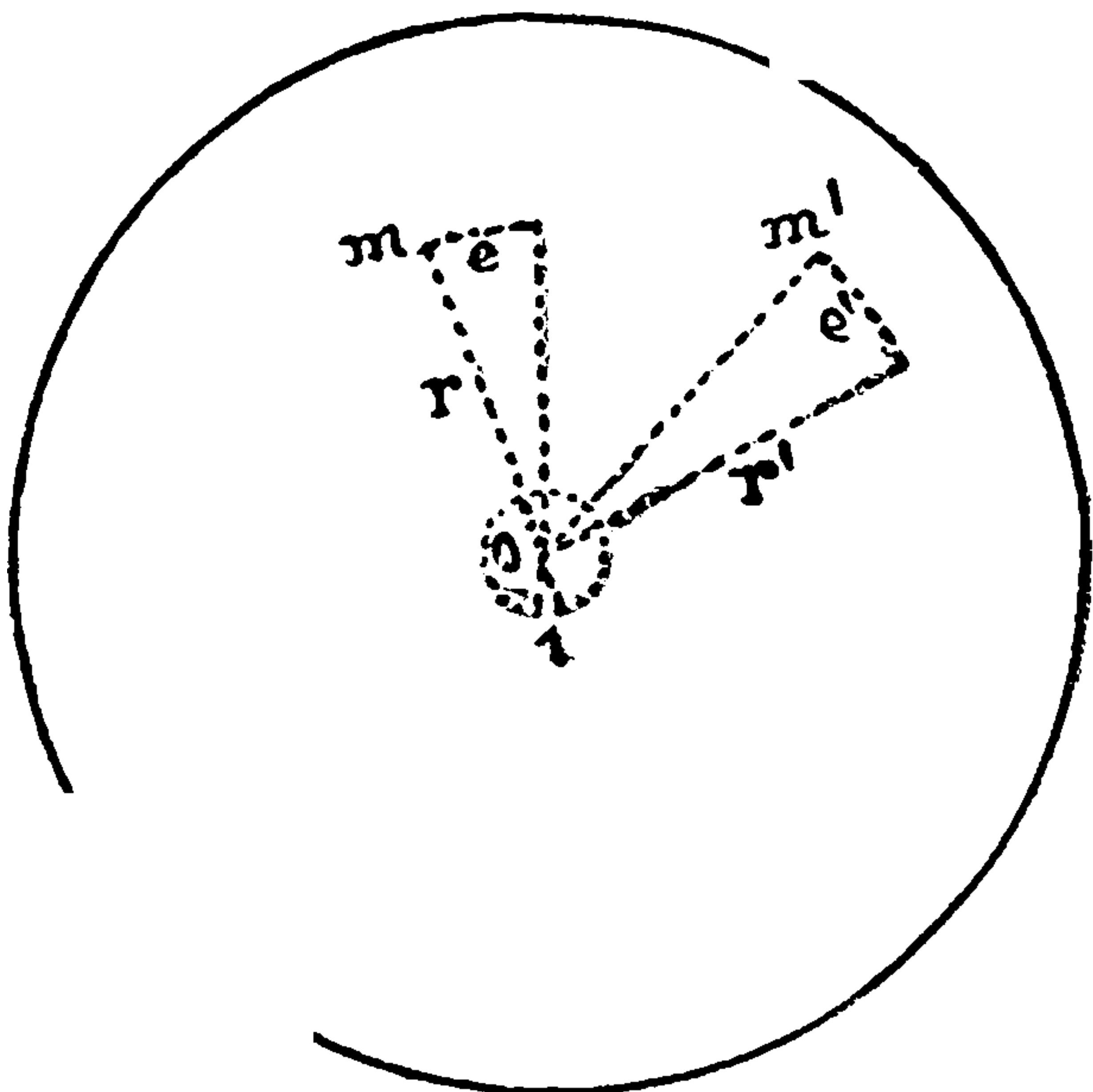

Fig. 4

The velocity of such a motion can only be determined by considering at the same time the path traversed in 1 second by a point of the body and the distance of this point from the axis of rotation. In order to avoid this double data, we consider the points which are at the unit of distance from the axis and we call the *angular velocity* the length of the arc described in 1 second by a point situated at the unit of distance from the axis.

Let  $w$  be this arc, we will have, for the velocity  $v$  of another point situated at the distance  $r$

$$v = r w,$$

from whence we conclude  $w = \frac{v}{r}$ . Consequently, the angular velocity is obtained by dividing the space which is traversed by any point in 1 second, by the radius of the circumference which it describes.

**35. Mass of a body.** The quotient of the weight of a body in any place on the globe, by the acceleration due to gravity at this



place is constant. This value is what is called in mechanics the *mass* of the body. This quantity, which is of a particular nature since it is nothing else than a quotient, can be subjected to calculation just as any other quantity. In designating it by  $M$ , we have

$$M = \frac{w}{g} \text{ from whence } Mg = W \text{ and } g = \frac{w}{m}$$

**36.** The product  $Mv$  of the mass  $M$  of a moving body by the velocity which it possesses, takes the name of *quantity of motion*.

**Work of a Force.**

**37. Definition.** We call in mechanics *work of a force* the product of the intensity of this force by the path traversed by its point of application. In other words :

The work produced by a force constant in magnitude and in direction is represented by the product of the intensity of this force by the projection of the distance traversed by the point of application on the direction of the force.

Thus, the path and the force being in the same direction, we will have (Fig. 5)

$$W = F \times AB.$$

If the path  $AB$  and the force  $F$  have not the same direction,



Fig. 5

we will project in this case the path  $AB$  on the direction  $AF$  and we will have (Fig. 6)

$$W = F \times AC$$

Let us observe that the projection of the path on the force is greater as the angle  $BAC$  becomes smaller ; the work will then

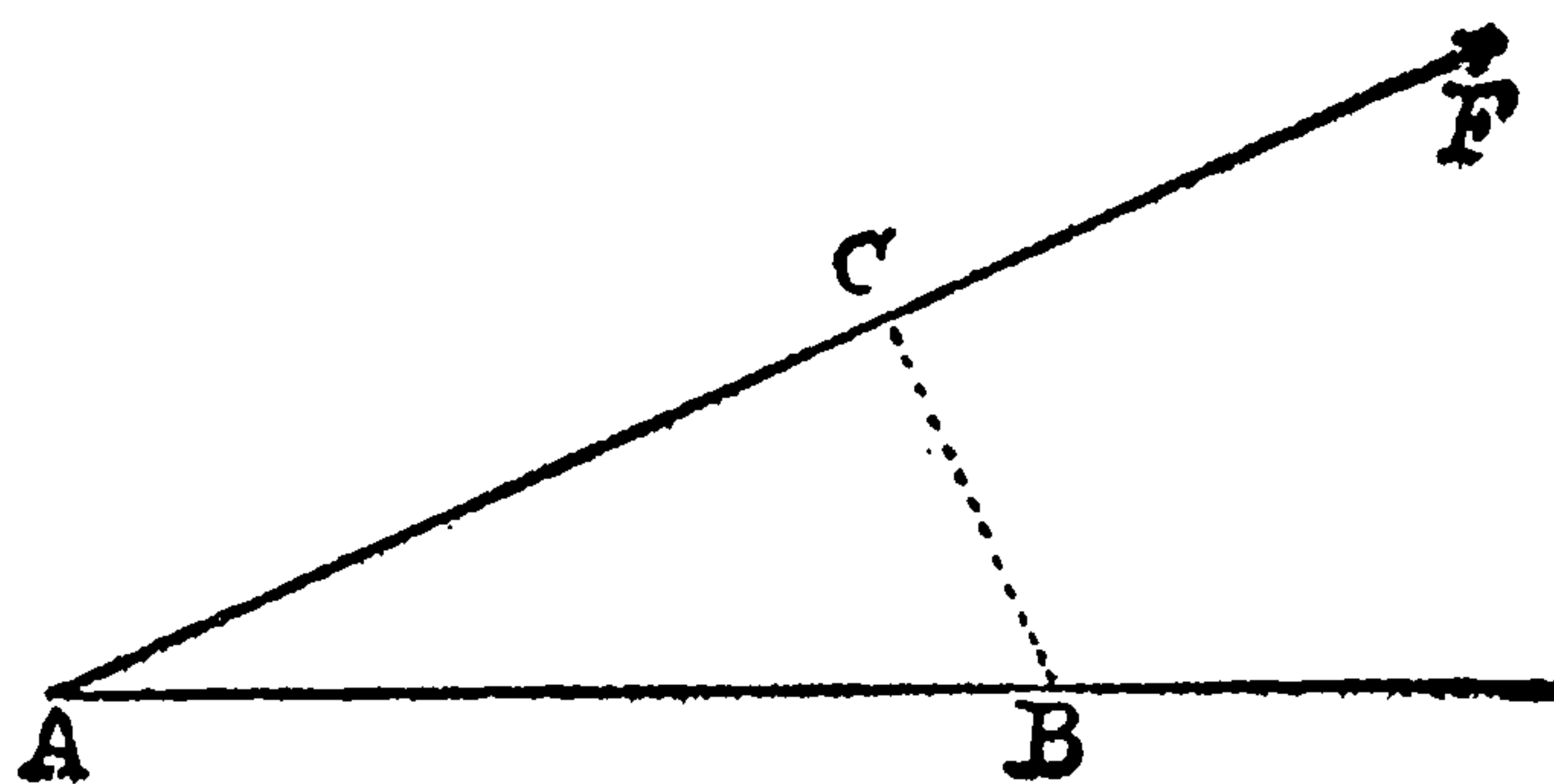

Fig. 6

be greatest when  $AB$  and  $AF$  will have the same direction. If the angle  $BAC$  becomes greater, the projection diminishes, and

becomes nothing when the angle is equal to  $90^\circ$ ; in this last case the work is null.

**38. Work of a force tangent to a wheel.** On imagining the movement of rotation of the wheel to be very small, we can admit that the movement takes place along the tangent. Let us call  $F$  the force and  $s$  the space traversed in its direction, we will have for this slight displacement

$$W = F \times s.$$

When the wheel will have made a complete revolution, the path  $s$  will have become a circumference and we will have the work for one revolution expressed by

$$W = F \times 2 \pi r.$$

**39. Unit of work.** We have chosen for *unit of work* that which is the product of the unit of force by the unit of distance, that is to say, in mechanics, of the kilogramme by the meter and in horology, of the gramme by the millimeter. We have given to this unit the name of *kilogrammeter* for the machines and of *grammillimeter* for the more delicate pieces of horology. As abbreviation, we will designate by the letters gr. m. this last unit which we will make use of in the entire extent of this course. If, for example, the force is 3.5 grammes and the distance 0.4 millimeters, the work of the force will be

$$W = 3.5 \times 0.4 = 1.4 \text{ gr. m.}$$

**40. Active power.** A weight  $P$  which falls from a height  $h$  generates a certain work that we can represent by the product

$$P \times h.$$

We find in mechanics that every body falling from a height  $h$  is animated by a velocity  $v$  which is connected with the height  $h$  by the relation

$$v^2 = 2 gh,$$

from which expression we can draw

$$h = \frac{v^2}{2g}.$$

Replacing in the equation of work  $Ph$ ,  $h$  by this last value, we will have

$$Ph = P \times \frac{v^2}{2g},$$

which we can also write

$$Ph = \frac{1}{2} \frac{P}{g} v^2,$$

but  $\frac{P}{g}$  being the mass  $m$  of the body, we will have at length

$$Ph = \frac{1}{2} m v^2.$$



The expression  $\frac{1}{2} m v^2$  has received the name of *active power*. We can then say that the active power of a body in motion is half the product of its mass by the square of its velocity ; or, also, that the mechanical work which imparts a certain velocity to a body is equal to the active power which animates that body.

We give the name of *active force* to twice the active power ; we have then

$$\begin{aligned} \text{Active power} &= \frac{1}{2} m v^2, \\ \text{Active force} &= m v^2. \end{aligned}$$

**41.** Every body in motion is capable of doing work. In effect the body has a mass  $m$  ; it has a velocity  $v$ , since it is in motion, consequently the product  $\frac{1}{2} m v^2$  gives us the value of the work  $Ph$ , to which the velocity  $v$  corresponds ; we can therefore say that every body in motion is capable of producing work.

**Moment of a Force.**

**42.** Let us now imagine two cylinders of different diameters turning around an axis  $O$  (Fig. 7) and let us admit, for example, that the first is three times as great as the second. Let us suspend weights at the ends of light cords wrapped around each cylinder, in such a manner that each of these weights acts in a contrary sense to the other. In order that equilibrium may exist in this system, we will find that the weight fixed to the small cylinder should be three times as great as that which is fixed to the large one. In this manner, if we turn the cylinder one revolution, one of the weights will rise while the other will fall ; the weight  $p$  traversing a path represented by  $2 \pi \times 3$  its work will be

$$2 \pi \times 3 p.$$

The weight  $P$  traverses a path  $2 \pi \times 1$ , producing at the same time a work

$$2 \pi \times 1 P,$$

Since we have  $3 p = P$  we can admit

$$(a) \quad 2 \pi \times 3 p = 2 \pi \times 1 P,$$

and there will be equilibrium, because the mechanical work of one of the weights is equal to that of the other. The equality of the

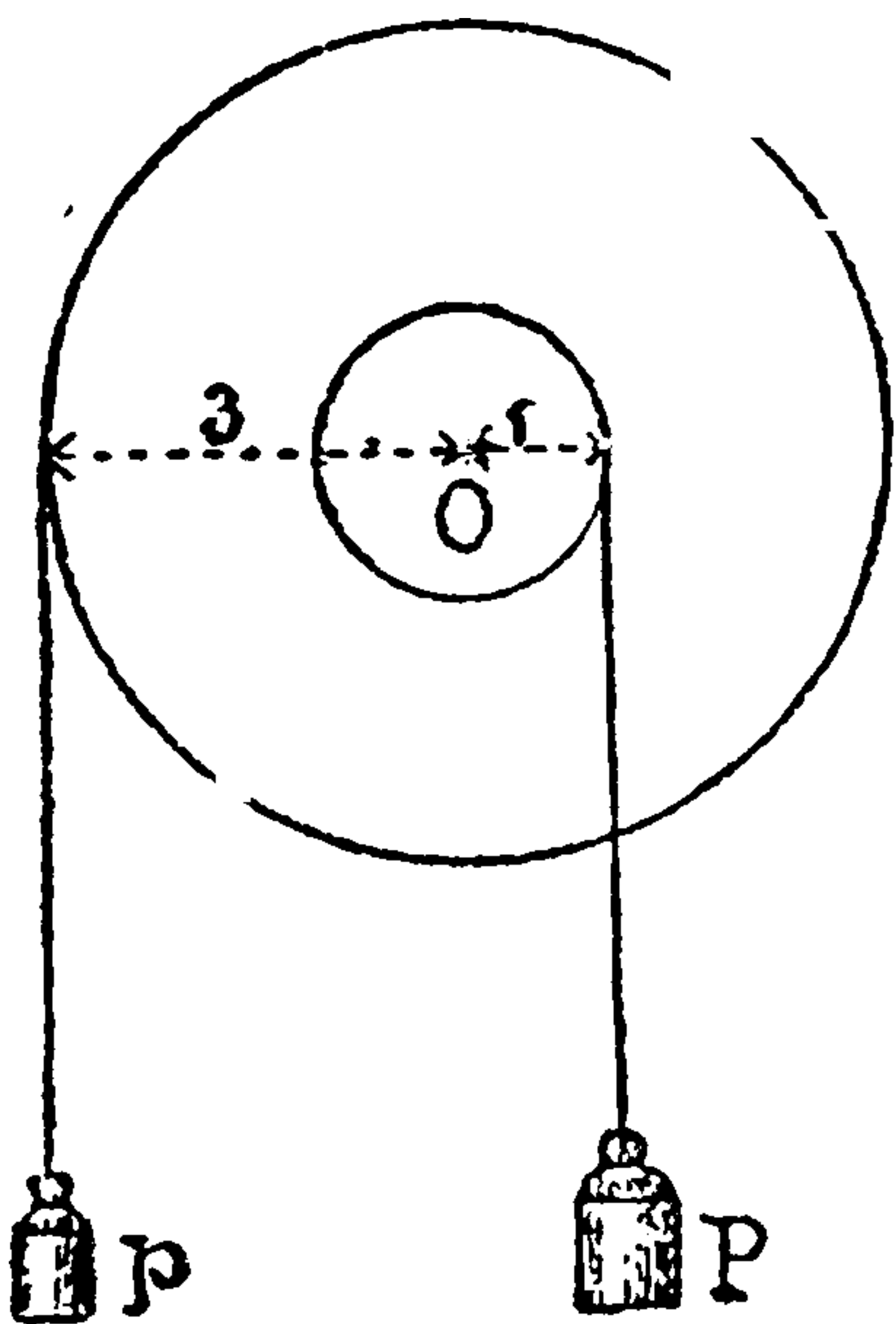

Fig. 7



work of these two weights will exist also when we make the cylinders describe only a fraction of a revolution : as small as this fraction may be.

Dividing the equation (a) by  $2 \pi$  we obtain

$$3 p = 1 P.$$

The figures 3 and 1 are the respective lengths of the radii of each cylinder ; this radius takes the name of *lever arm* and the above product of the intensity of the force by the lever arm is called the *moment of the force*.

Summing up, we have just examined the state of a body which can turn around a fixed point ; to this body are applied two forces whose work mutually counteracting, produces equilibrium. We call such a system a *lever*.

In every lever, for equilibrium to exist it is therefore necessary for the moments of the two forces in action to be equal.

Imagining the system in motion, under the action of an exterior impulse, we will find the *work* of the forces on multiplying their *moment* by the angle traversed ; in this new condition of the body the work of the forces will then be equal.

**43. Lever.** Practically, a *lever* is a solid body, movable around a fixed point and acted upon by two forces tending to

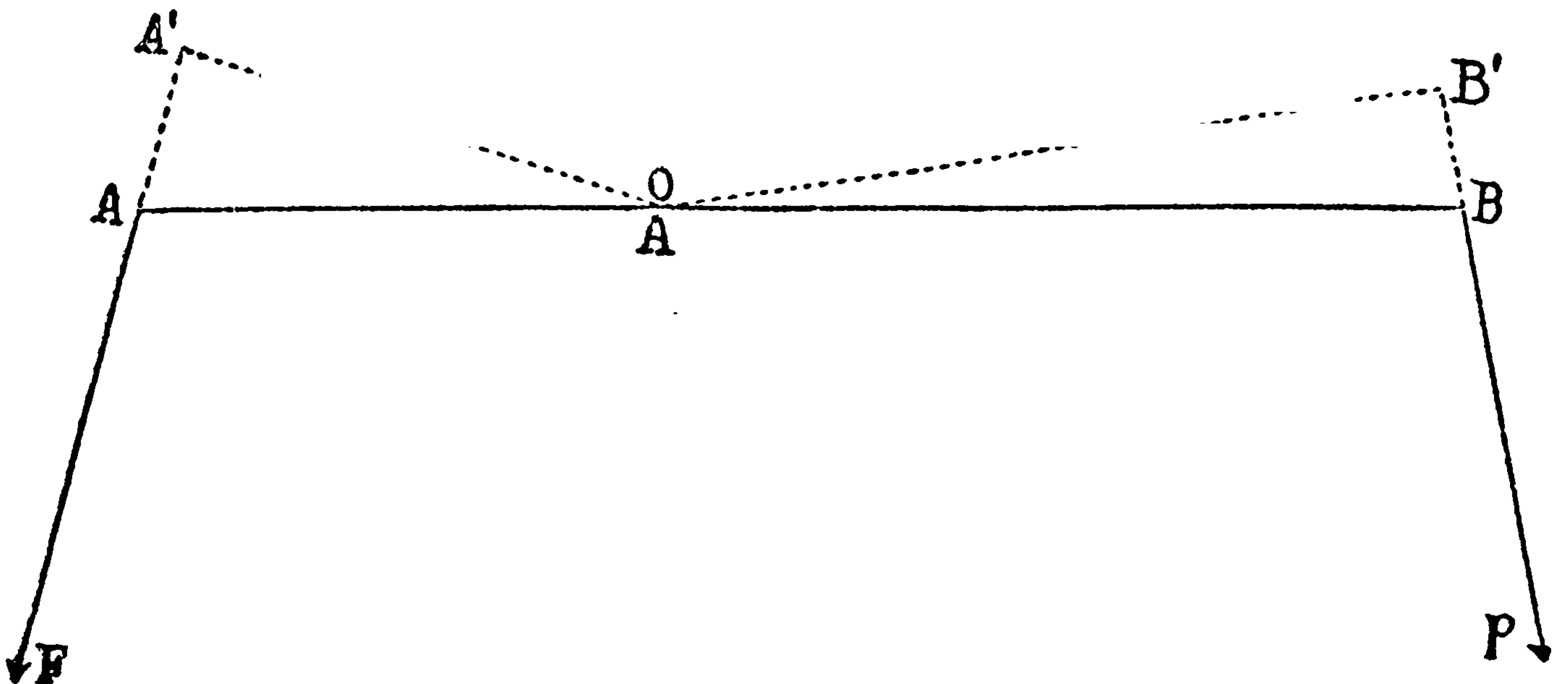

Fig. 8

make it turn in contrary directions. Fig. 8 represents a lever in which  $O$  is the fixed point.  $P$  and  $F$  the two forces. The lever arms of the forces  $P$  and  $F$  are the distances from the fixed point  $O$  to the two forces, that is to say, the perpendicular  $O A'$  and  $O B'$  dropped on the direction of these forces.





**THIS PAGE IS LOCKED TO FREE MEMBERS**

Purchase full membership to immediately unlock this page

# DELVE INTO FANTASY, MAGIC, MYTHOLOGY & FOLKLORE

Forgotten Books'  
Full Membership gives  
access to 797,885 ancient  
and modern, fiction and  
non-fiction books.

**Continue**

\*Fair usage policy applies



of the movement of the parts which they operate ; it is consequently to these that is due the motion of the machine.

**2d. Useful resisting forces**, those which the materials on which the machine operates, oppose to the movement of the parts which act on them ; it is these then which we desire to overcome.

**3d. Passive or hurtful resisting forces**, which arise from the movement of the different parts of the machine to oppose this movement. We have already seen that they are due to the friction of these parts among themselves or on foreign bodies, to shocks which can be produced between these parts on account of sudden changes in speed and to the resistance of the air.

Considering the motive forces as positive, since they act in the direction of the movement, the useful resistances and passive resistances will then be negative. If we suppose the system animated by a uniform movement, the algebraic sum of the work of all the forces for any given time will be null, since the gain or the loss of active power is null, and we will have, in designating by  $W_m$  the work of the motive forces,  $W_u$  the useful work and  $W_p$  the work of the passive forces :

$$W_m - W_u - W_p = 0,$$

from whence

$$W_m = W_u + W_p,$$

which shows us that, the movement being uniform, the motive work is equal to the useful work, augmented by the work of the passive forces.

When in any machine this formula is verified, we say then that there is “dynamic equilibrium.”

When the movement of a machine is periodically uniform, the gain or the loss of active power is null only for a whole number of periods ; for this time we still have

$$W_m = W_u + W_p.$$

We say then that the machine is in “periodic dynamic equilibrium ;” this is the ordinary state of machines, not only on account of the shape of their parts, but because of the variations more or less great in the motive forces, and especially in the resistances.

Thus  $W_u$  is always inferior to  $W_m$  ; that is to say, a machine renders less useful work than the motive power applied, because the work of the passive resistances is never null.



47. Calling  $P$  the motive force acting on any machine, and  $Q$  the useful resistance overcome by this machine,  $E$  and  $e$  being the spaces traversed by the points of application of  $P$  and of  $Q$  in the direction of these forces and in any equal time, at the beginning and at the end of which the speed of the machine is the same, the equation of dynamic equilibrium gives, supposing first that the passive resistances are null :

$$PE = Qe, \text{ or } \frac{P}{Q} = \frac{e}{E}$$

From the equality between the work and the power and that of the resistance, it follows that for the same motive work  $PE$ , according as the force  $Q$  may be multiplied by  $\frac{1}{3}$ ,  $\frac{1}{2}$ , 2, 3, etc., the space  $e$  will be divided respectively by the same numbers ; from whence comes the maxim well known in mechanics: "That which we gain in force we lose in speed, or what amounts to the same thing, in distance, and reciprocally."

The preceding proportion enables us to calculate any one of the four quantities  $P$ ,  $Q$ ,  $E$ ,  $e$ , when we know the three others.

For any simple or complicated machine, if the question is to find the resistance  $Q$  that a power  $P$  can overcome, we determine the spaces  $E$  and  $e$  traversed in the same time by the points of application of the forces  $P$  and  $Q$ .  $E$  and  $e$  are any distance whatever if these points of application have uniform movements, but we take them corresponding to a period if the movement of the machine is periodic. When the machine is constructed, by putting it in motion of any sort, we determine the values of  $E$ ; we deduce those of  $e$  from the relations of the spaces traversed by the different parts which transmit the movement of the point of application from  $P$  to that of  $Q$ .

Let us suppose that the resistance to be overcome  $Q$  be 100 kilogrammes, and that it is desired to determine what will be the power of  $P$ , neglecting the passive resistances. We commence by determining the corresponding values of  $E$  and  $e$ , as has just been shown. Let  $E = 2.5$  m., and  $e = 0.80$  m.; replacing the letters by their values, in the preceding equation we will have

$$\frac{P}{100 K} = \frac{0.80}{2.5}$$

from whence

$$P = \frac{100 \times 0.80}{2.5} = 32 \text{ kilogrammes.}$$

If we had known  $P$  we would have been able to determine  $Q$ , as we have just done for  $P$ .



48. In machines, especially in industrial machines, the passive resistances are so considerable that we cannot neglect the work that they absorb ; the dynamic equilibrium is then expressed by

$$W_m = W_u + W_p .$$

For a certain displacement of the parts of the machine, the work  $W_m$   $W_u$   $W_p$  will be valued as in the preceding case ; thus  $P$  being the power,  $Q$  the useful resistance,  $R, R', \dots$  the different passive resistances, and  $E, e, i, i' \dots$  the corresponding distances traversed in the same time by the points of application in the direction of these forces, we have

$$P E = Q e + R i + R' i' + \dots$$

49. It may happen that one or several hurtful resistances come from the shocks between the parts of the machine. The work absorbed by these resistances is no longer valued by the product of a force by the distance that its point of application traverses, but by the loss of active power due to the shock, and this loss, valued in units of work, enters into the second member of the equation as the other hurtful works  $R i R' i' \dots$

By the aid of the preceding equation, knowing in a machine two of the three following works : the  $W_m = P E$ , the  $W_u = Q e$  and the  $W_p = R i + R' i' + \dots$  we determine the third.

50. Ordinarily one decides to set up a machine capable of producing a given useful work.

$$W_u = Q e$$

It is then necessary to determine the  $W_m = P E$ , capable of producing not only this useful work but of overcoming also the secondary resisting works.

One should then commence by calculating this hurtful work, which is done by determining the values of the different passive resistances  $R, R' \dots$  in function of  $Q$ , and afterward  $W_p$  in function of  $W_u$ .

Having  $W_p$  and  $W_u$ , we can determine the value of  $W_m$  expressed as has been said in kilogrammeters and in grammillimeters.

51. The motive work  $W_m$  being represented by 100, the useful and hurtful works  $W_u$  and  $W_p$  being for example, 75 and 25, the loss is then 25 for 100; we say in this case that the *product* of the machine is 75 per cent. If it were possible for the loss to be nothing, the product would be 100 per cent ; this fact can never be



realized, which renders absolutely illusive the hypothesis of perpetual motion. The product of a machine rarely passes 80 per cent.; it is nearly always much inferior to this limit.

In this preliminary study we have desired to establish a basis which is nothing more than the enunciation of some fundamental principles of mechanics. In the course which is about to follow, we will make a constant use of them, and all their developments will be found in the text.



---

## General Functions of Clocks and Watches.

---

### The Oscillations of the Pendulum and their Relation to the Motive Force.

**52.** We know that in clocks and watches time is measured by the periodically-uniform movement of the *pendulum* or of the *balance wheel*.

History relates that Galileo, while yet young, was struck with the regularity of the pendulous vibrations of a candelabra in the Cathedral of Pisa. He studied the laws of these oscillations and used a pendulum later on for his astronomical observations. This instrument, in its primitive simplicity, presented two difficulties; when the astronomer left his pendulum to itself, after having diverted it from the vertical position, the oscillations which were produced having at first a certain amplitude, diminished little by little, then finally ceased entirely. He was then obliged, from time to time, to give an impulse to his pendulum. The second of these difficulties was the necessity for him to count the number of these oscillations. It is said that he charged a servant with the execution of these two functions.

Now, the mechanism of the clock performs unaided these two functions with a regularity that the man could never achieve directly.

**53.** Let us seek, in the first place, for the causes which make the oscillations of a free pendulum constantly diminish.

When a pendulum is moved from its position of equilibrium  $O A$  (Fig. 10), the attraction of the earth, which was perfectly neutralized by the resistance of the point of suspension  $O$ , is no longer so in the oblique position  $O B$ . It would cause the ball to descend vertically if the cord did not force it to describe the arc of a circle; at each instant of its returning course the speed of the pendulum increases a small quantity until it reaches anew the vertical position  $O A$ . From there on the inertia, or, if one prefers it, the velocity acquired, forces it to continue in its motion and makes it describe the arc  $A B'$ ; from that instant also gravity, acting in the contrary direction of the motion, tends to stop it. The velocity diminishes constantly, and would become null at the moment when the ball would arrive at a height equal and



symmetrical to that from whence it started, if there were no other forces than those of gravity which would act on the pendulum.

These forces which exert their action in the contrary direction to the motion, are *resistances of the suspension and of the air*; it is then to these that is due the diminution of the amplitude of the pendulum's oscillations. If these forces could be suppressed, the motion would be perpetual.

54. There are two manners of suspending a pendulum—by means of a knife edge and by means of flexible springs.

The *knife-edge suspension* is made in such a manner that the friction is very slight, without its being, however, completely annulled. This kind of suspension can be used in regulators whose amplitude of oscillation is generally small. For this purpose a sort of knife blade slightly rounded on its edge, and working in the interior of a hollow cylinder, is fixed transversely to the pendulum rod (Fig. 11).

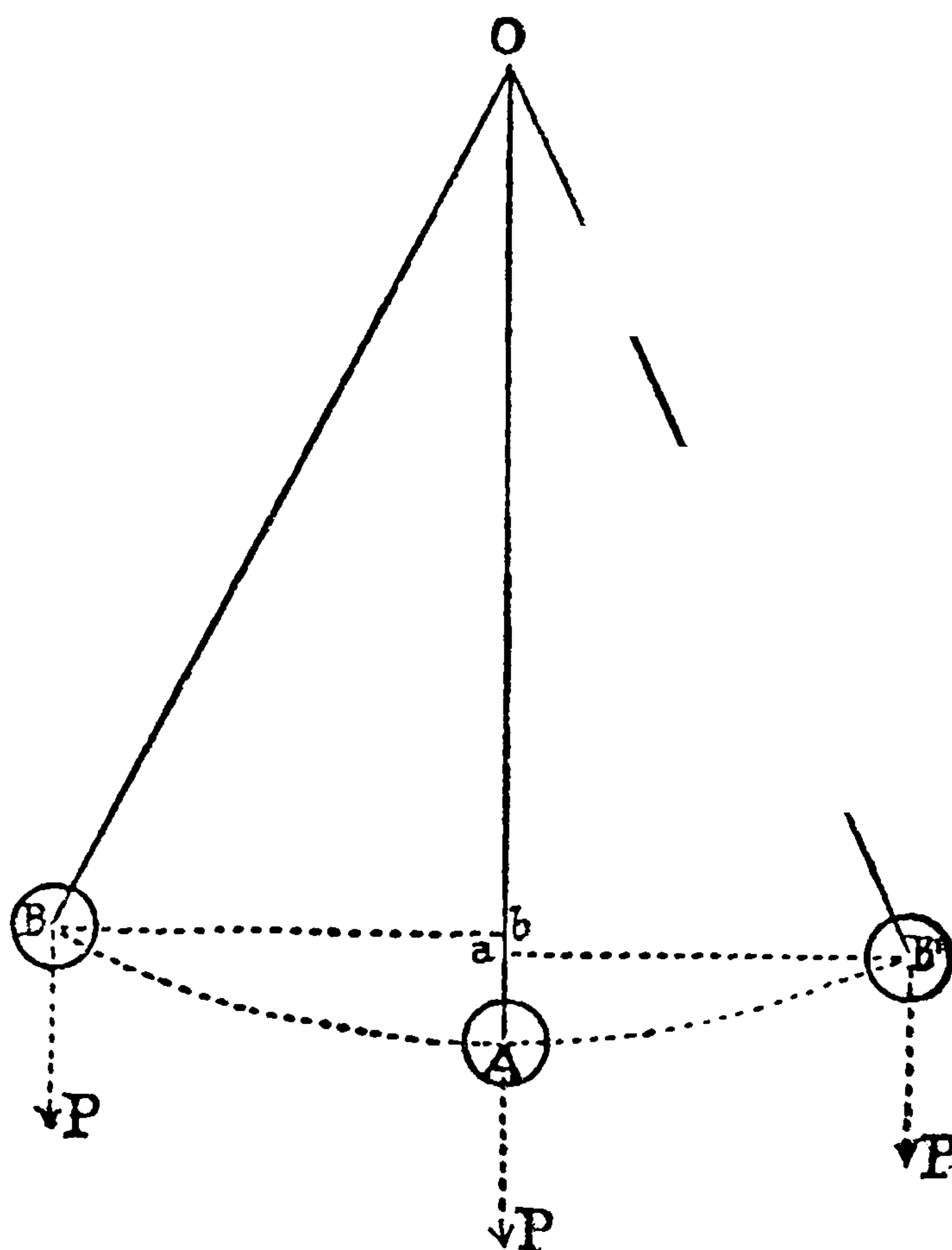

Fig. 10

The knife edge, as also the hollow cylinder, should be made of exceedingly-hard material and thoroughly polished. The knife edge can then be regarded as a pivot of very small dimensions. (We will see later on that the work of friction is proportional to the pressure and to the greatness of the amplitude.)

The *spring suspension* consists in terminating the upper end of the pendulum rod by two short blades of steel securely fastened on the other end to any fixed piece. In this system, which is also very much used, there exists a loss of force resulting from the distorting of the blades.

55. Concerning *the resistance of the air*, we admit that it is in direct relation to the largest transverse section of the body and to the square of the velocity with which it traverses the atmosphere;



it depends, moreover, whether its form is more or less tapering. The work of this force should be proportional to the cube of the size of the amplitudes.

56. Now that we know the nature of the forces which act on the pendulum during its vibrating motion, we can determine their work and establish the relation which connects them with each other.

The *motive work*  $W_m$  developed by gravity during the descending half oscillation, is equal to the weight  $P$  of the pendulum multiplied by the projection of the arc  $BA$  (Fig. 10) on the direction  $OA$  of the force ; therefore, by the length  $Ab$  (37). We will write then

$$W_m = P \times Ab$$

The *resisting work*, that is to say the work of the forces which act in the contrary direction to the motion, is composed of two distinct forces :

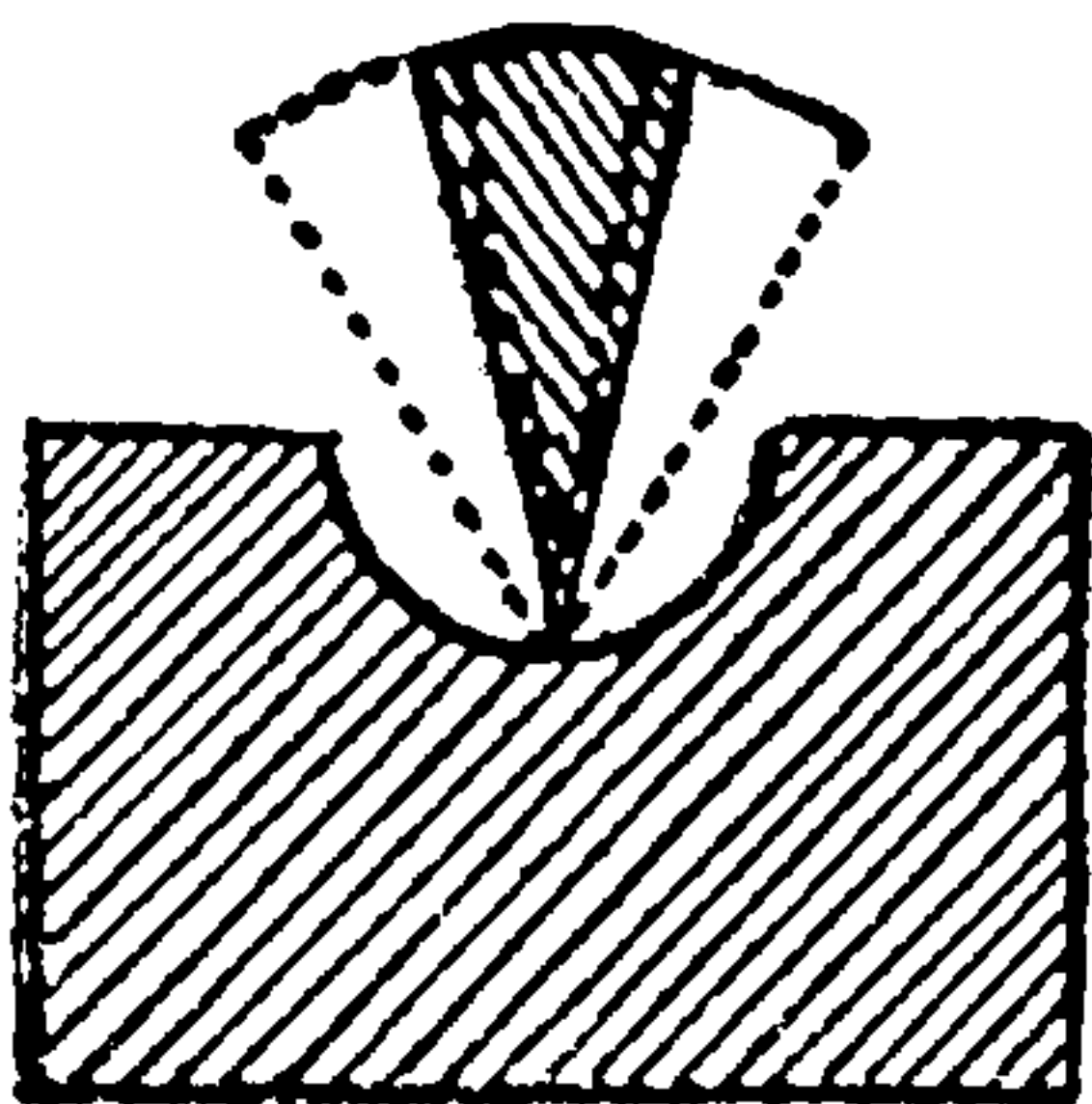

Fig. 11

1st. Of the work of gravity developed while the pendulum traversed the half oscillation ascending, therefore the weight  $P$  multiplied by the projection of the arc traversed  $AB'$  on the direction  $OA$  ; let us represent this work by the formula

$$W_u = P \times Aa$$

2d. Of the secondary resisting works arising from the resistances of the suspension and of the air. Knowing the lengths of the arcs  $AB$  and  $AB'$ , we find the work of the secondary resisting forces by multiplying the weight  $P$  of the pendulum by the difference of the projections  $Ab - Aa$  or  $ab$  ; we will then have

$$W_p = P \times ab$$

The motive work should be equal to the sum of the resisting works (46) ; we will therefore have

$$W_m = W_u + W_p ,$$

or substituting

$$P \times Ab = P \times Aa + P \times ab$$

57. For the oscillations of the pendulum to preserve the same amplitude, it is therefore necessary that at each of these oscillations it must receive an impulse whose work should be equal to  $P \times ab$ .

58. Since the secondary resisting work increases with the amplitude of the oscillations, it is necessary that the impulse, or what we should call the work of the maintaining force, should be greatest when we wish the pendulum to traverse the largest arcs.





**THIS PAGE IS LOCKED TO FREE MEMBERS**

Purchase full membership to immediately unlock this page

# HISTORY

Tens of thousands of important historical sources, many previously unobtainable, are now available for the first time with a Forgotten Books Full Membership.

Unlimited Access  
\$8.99/month

**Continue**

\*Fair usage policy applies





direction of the motion and tending to stop it. If it were possible to produce such a movement without there being any passive resistances acting on the balance wheel, the latter would traverse a

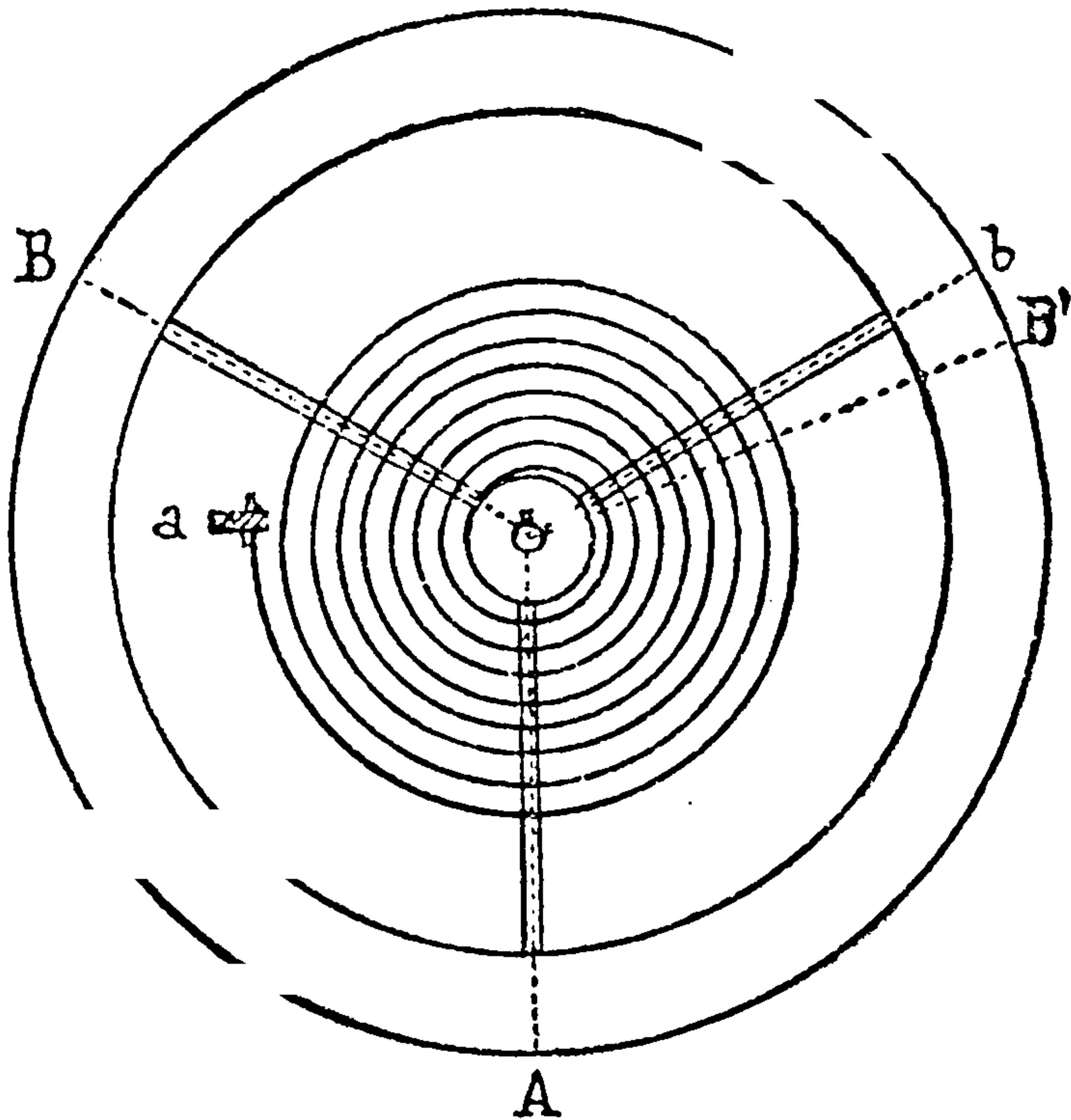

Fig. 12

new angle,  $A O b = \alpha$ , then would come back to  $B$ , and so on indefinitely.

It is not so in reality, for there are a number of resisting forces which act on the balance and which prevent it from arriving at  $b$ . These forces are :

1. The friction of the balance pivots.
2. The resistance of the air.
3. A loss of force resident in the spiral, the true cause of which is not absolutely defined but the existence of which can be perfectly established.

These secondary resisting forces have the effect of diminishing each oscillation a small quantity, which is represented in the figure by the angle  $B' O b$ . Calling  $\alpha'$  the angle  $B' O A$ , we have

$$B' O b = \alpha - \alpha'.$$

If, as we have done for the oscillations of the pendulum, we designate by  $W_m$  the motive work exerted by the spiral while the balance wheel traversed the angle  $\alpha$ ,  $W_u$  the resisting work proceeding from the spiral during the second part of the oscillation ; therefore, while the balance wheel traverses the angle  $\alpha'$ , and  $W_p$  the secondary resisting work of the passive forces, we would obtain the equality (46)

$$W_m = W_u + W_p,$$

or

$$W_p = W_m - W_u.$$

The work of the maintaining force should be, both for the balance and for the pendulum, equal to the secondary resisting work, if you wish to preserve the initial greatness of the amplitude of the oscillations ; otherwise expressed, the work of the maintaining force should be equal to the work of the force of the spiral while the balance wheel traverses the angle  $\alpha - \alpha'$ .



63. We can admit that the resisting work increases with the amplitude of the oscillations, as we have shown for the pendulum, and conclude that more motive work would be necessary to traverse larger arcs than for smaller ones.

64. We use exclusively for motive force in portable timepieces the elastic force developed by a spring enclosed in the interior of a

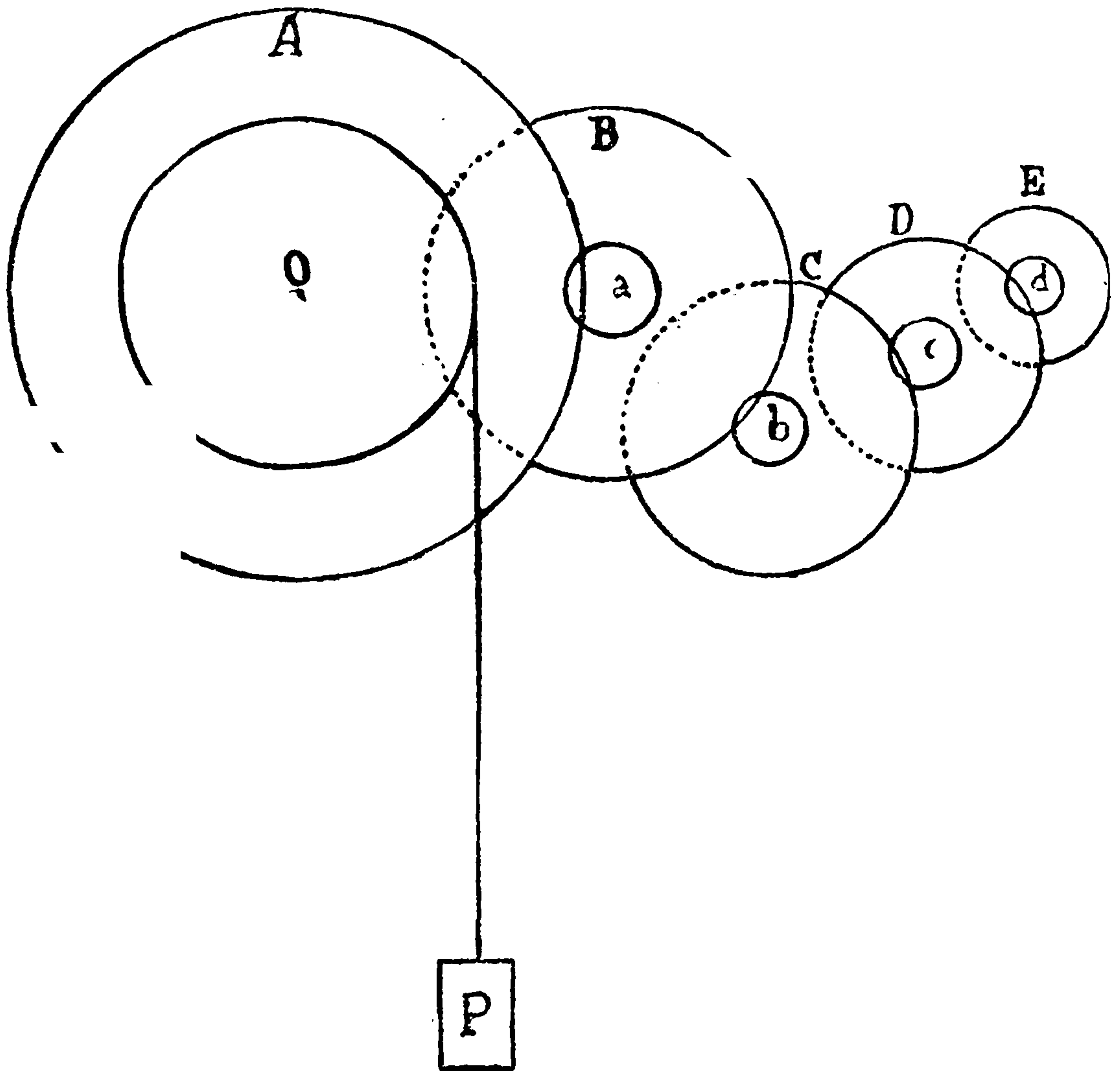

Fig. 13

cylinder called the *barrel*. This piece, generally toothed, turns around an axis, and this action is conveyed to the balance wheel by special mechanism, which we are going to pass rapidly in review.

### Wheel-Work.

#### Its Purpose in the Mechanism of Clocks and Watches.

65. The motive force, not acting directly either on the pendulum or on the balance wheel, is first transmitted by a system of toothed wheels or train of gearings that is called in technical language the *wheel-work* or *the transmission*. This force, thus transported, is received by a mechanism which is the *escapement*; it is



this last whose function it is to restore to each oscillation of the pendulum or balance wheel<sup>1</sup> the loss of force,

$$W_m - W_u,$$

occasioned by the secondary resisting forces.

**66.** When a weight is used as motive force, that weight is suspended to the extremity of a cord unwinding from a cylinder fixed concentrically on the axis of a toothed wheel. This wheel *A* (Fig. 13) gears in a second wheel much smaller than the first and which is called a *pinion*, on which is fixed concentrically a second toothed wheel *B*, which in its turn gears in the pinion *b*, and so on to the last pinion, on whose axis the escape wheel is fastened. The same thing takes place when the motive force is that of the spring in the barrel. In this case the barrel gears directly into the first pinion *a*.

**67.** The different wheels of the wheel-work in watches bear the following names :

1. The barrel.
2. The center wheel \* (large intermediate wheel).
3. The third wheel (small intermediate wheel).
4. The fourth wheel (seconds wheel).
5. The escape wheel (escape wheel).

The pinions carrying the four last mobiles take the same name as the wheel to which they are riveted.

**68.** The mechanical work of the motive force is then transmitted by the wheel-work to the escape wheel. This transmission cannot be effected, however, in a complete manner, because part of the force is absorbed by the friction of the gearings and of the pivots, by the inertia of the moving bodies and sometimes also by the defects resident in the gearings.

**69.** Beside the transmission of the force, the wheel-work should fulfil another function : this is to reckon the number of oscillations that the pendulum or the balance wheel executes during a determined time and to indicate this number by means of hands on a properly-divided dial. We must, therefore, combine the relation of the numbers of teeth in the wheels to the numbers of leaves in

---

\*We give here the appellations still in use in most of the horological workshops of the canton of Neuchatel. The names of large and of small intermediate wheels are really obsolete and should be replaced by the following, which are in better relation to the positions of these two mobiles: "Center wheel" for the first and "intermediate wheel" for the second. To avoid confusion, we conserve, however, in this edition the denominations in use in this locality. (The usual names employed in America have been made use of by the translator.)



the pinions, so as to make this indication conform to the division of time. Thus, the center wheel carrying on its axis the minute hand should complete one rotation during one hour, and the fourth wheel carrying the second hand should make one revolution each minute.

(The hour hand is carried by a wheel forming part of an accessory wheel-work, which will occupy our attention later.)

### **Escapements.**

**70.** Several kinds of escapements have been constructed, differing more or less from each other, but whatever they may be their function consists always in restoring to the pendulum or to the balance wheel the speed which the passive resistances have made them lose. The most perfect escapement will be the one which will effect this work by altering as little as possible the duration of the oscillation.

Since the movement of the balance wheel as well as that of the pendulum is an oscillating movement, the escape wheel is arrested during part of the oscillation ; it is only when the balance or the pendulum has traversed a determined arc that the wheel becomes free and is put in motion. During this time it acts either directly on the balance, as in the "cylinder" escapements or the "detent," or on an intermediate piece, as in the "anchor" escapements. After having traversed the angle of impulse determined, the wheel is arrested anew until another disengagement. The manner in which this arresting is produced differs according to the kind of escapement.

**71.** In most of the escapements the action of each tooth of the wheel corresponds to two oscillations of the balance wheel or pendulum. Thus, in a watch, the balance wheel executes 30 oscillations during one complete revolution of a wheel of 15 teeth ; in a clock, the pendulum makes 60 oscillations during one revolution of an escape wheel of 30 teeth.

**72.** To recapitulate, the study of the functions of horological mechanism can be divided into four principal parts, which are :

1. Power—study of motive powers.
2. Transmission—study of wheel-works and gearings.
3. Reception—study of the escapements.
4. Regulation—study of regulating and adjusting.



## Maintaining or Motive Forces.

### The Weight as a Motive Force.

73. We will adopt in the beginning as *units* in the calculations, the *millimeter* as unit of length, the *gramme* as unit of weight and of force, which gives us for the unit of mechanical work the *grammillimeter*. We will choose the *second* as the unit of time.

74. Among all the forces which are used in horology in order to maintain the oscillations of the pendulum, the weight is at once the most regular, the most simple to obtain and the one whose intensity can be regulated with the greatest facility.

75. If a certain weight  $P$  (Fig. 13) is suspended at the end of a cord wrapped around a cylinder the radius of which increased by half the thickness of the cord is equal to  $r$ , the work of this force while the cylinder executes one revolution will be expressed by (38)

$$P \times 2 \pi r.$$

Dividing this work by the number  $N$  of oscillations that the pendulum executes during one revolution of the cylinder, we will have as quotient the mechanical work developed by the weight during one oscillation of the pendulum, thus :

$$W P = \frac{P \times 2 \pi r}{N}.$$

We know that a part of this mechanical work is lost during its transmission to the pendulum: calling  $W_u$  this last work, we should have the equality

$$W P - W_u = W_p,$$

in which we will replace  $W P$  by its value, thus :

$$\frac{P \times 2 \pi r}{N} - W_u = W_p.$$

We see then that the determination of the work which the pendulum receives at each oscillation ( $W_p$ ) depends also on the knowledge of the work lost during its transmission by the wheel-work and the escapement. We understand, consequently, the difficulty that there is to determine the motive work, since this work does not depend alone on the weight and on the dimensions of the pendulum but also on the resistances to be overcome during an oscillation.

Here are, however, two calculations taken from practice which will aid in more firmly fixing the ideas on this subject :



76. *First Calculation.*—The motive weight of a regulator beating seconds is 2000 grammes ; this weight is suspended at the end of a cord which unwinds from a cylinder, with a radius of 15 millimeters. What will be the work produced by this weight during the unit of time?

The mechanical work effected by the weight while the cylinder executes one revolution will be

$$2000 \times 2 \pi \times 15 = 188496 \text{ gr.m.}$$

A wheel  $A$  is fastened to the cylinder (Fig. 13) gearing in a pinion which carries on its axis a second wheel  $B$ , which in turn gears into a pinion  $b$ , this last pinion carrying on its axis the minute hand should then execute one revolution an hour. The numbers of teeth and leaves of these moving bodies are distributed in such a manner that the pinion  $b$  executes 45 turns while the cylinder makes one ; consequently, one revolution of the cylinder takes place in 45 hours or in

$$45 \times 60 \times 60 = 162000 \text{ seconds} = N.$$

We will then obtain the work produced by the weight during one oscillation of the pendulum, by the application of the formula,

$$W P = \frac{P 2 \pi r}{N} = \frac{188496}{162000} = 1.163 \text{ gr.m.}$$

We will show the manner of calculating the work lost during the transmission when we treat of the questions of frictions, of the inertia of the wheels, etc. ; for the present, let us admit these calculations as made and adopt for this special case the value

$$W_u = 0.413 \text{ gr.m.}$$

We will then have

$$W_m - W_u = W_p,$$

or

$$1.163 - 0.413 = 0.75 \text{ gr.m.}$$

The weight of 0.75 grammes, exerting its action on a distance of one millimeter, is then sufficient to keep up the oscillations of a pendulum whose weight is about 6500 grammes. The amplitude of the oscillations is  $2^\circ 6'$ .

77. Although that which follows is a little outside of the problem which we have just solved, let us profit, however, by the data that we possess to calculate further the angle

$$B O A - B' O A \text{ (Fig. 10).}$$

This adjunct to the preceding solution does not, moreover, lack in interest.



Following an equation previously established (56), the work of the force capable of maintaining the oscillations of a pendulum was expressed by

$$W_p = P \times a b.$$

We can then put

$$P \times a b = 0.75 \text{ gr.m.};$$

or, again,

$$a b = \frac{0.75}{6500} = 0.0001154.$$

The length of a simple pendulum beating seconds is about 994 millimeters for our latitude.\* Let us suppose that the entire weight of our pendulum is assembled at a single point, the distance from the center of gravity to the center of suspension will then be equal to the length of a simple pendulum beating seconds. We will have

$$\begin{aligned} A b &= 994 - 994 \cos A O B \\ A a &= 994 - 994 \cos A O B'. \end{aligned}$$

From Fig. 10 the difference  $A b - A a$  gives the length  $a b$ ; subtracting then the two foregoing equations, one from the other, we obtain

$$a b = 994 \cos A O B' - 994 \cos A O B,$$

whence follows

$$\cos A O B' - \cos A O B = \frac{a b}{994} = \frac{0.0001154}{994}.$$

since the angle  $A O B$  is equal, in this case, to half of  $2^\circ 6'$ , which is  $1^\circ 3'$ , we can write, after having completed the calculation of the second member of the equation:

$$\cos A O B' - \cos 1^\circ 3' = 0.000000116.$$

In order to determine the value of the angle  $A O B - A O B'$ , we can find in a table of natural trigonometrical lines the difference between the cosines of the angles  $1^\circ 2'$  and  $1^\circ 3'$ . This difference is 0.0000053; we will then have the proportion,

$$\frac{0.0000053}{0.000000116} = \frac{60''}{x}$$

$$\text{from whence } x = \frac{60 \times 116}{5300} = 1.3'';$$

$$\text{then } A O B - A O B' = 1.3''.$$

**78. Second Calculation.**—A clock from the Black Forest, such as those that were manufactured in large quantities during the years between 1840 and 1850, runs under the action of a weight of 625 grammes. This weight descends in 24 hours from a height of 1250 millimeters. What is the work produced by this force during one second?

The work produced during the descent of the weight will be

$$W = 625 \times 1250$$

in 24 hours; during one second it will be  $24 \times 60 \times 60 = 86400$  times less; therefore

$$W_m = \frac{625 \times 1250}{86400} = 9 \text{ gr.mm.}$$

\* Latitude of Neuchatel





**THIS PAGE IS LOCKED TO FREE MEMBERS**

Purchase full membership to immediately unlock this page

# DELVE INTO FANTASY, MAGIC, MYTHOLOGY & FOLKLORE

Forgotten Books'  
Full Membership gives  
access to 797,885 ancient  
and modern, fiction and  
non-fiction books.

**Continue**

\*Fair usage policy applies



The moment of the force of the weight will give us then the moment of the force of the spring.

**82.** If the lever of the preceding experiment has not its center of gravity on the axis, it will still be necessary to take account of the effect produced by the weight of this lever, which cannot, practically, be reduced to a simple geometric line. In order to determine this we must find the distance of the center of gravity of the lever from the axis, and multiply this value by the weight of the lever. We then add this product to the moment of the force previously obtained.

Let us suppose, for example, that a weight of 20 grammes, suspended at the extremity of a lever arm 200 millimeters long, makes equilibrium with the elastic force of a barrel spring. The product

$$20 \times 200 = 4000$$

represents the moment of the force exerted by the weight.

If, moreover, the weight of the lever is 7 grammes, and the distance from its center of gravity to the center of the arbor 143 millimeters, the moment of the force exerted by the lever will be

$$7 \times 143 = 1001.$$

Adding this value to the moment of the force of the weight, we obtain the moment of the force of the spring that we will designate by  $F$ , then

$$F = 4000 + 1000 = 5000 \text{ grammes}$$

in round numbers. This is the approximate value of the moment of the force of the spring in a watch of 43 millimeters (19 lines).

Let us remark that generally these levers are furnished with counter weights combined in such a manner that the center of gravity is found on the axis.

**83.** The number 5000 that we have just obtained, signifies that the spring considered is capable of making equilibrium with a weight of 5000 grammes suspended at the extremity of a lever arm equal to the unit of length, therefore 1 millimeter (Fig. 14).

**84.** Examining in this manner the force of a spring, we will prove that it varies very much according to the number of turns that it is set up. Experience proves in fact that the moment of the force of a spring being, for example, at its maximum point of tension, 5000 grammes, this moment constantly diminishes, and will not be more than about 3400 grammes when the barrel will have executed four rotations around its axis.



85. We understand then that the imperfections of the primitive watches being known, the ancient horologists should have sought means for correcting the inequality of the action of the motive spring, and that for this purpose they should have invented the ingenious arrangement of the *fusee*, which will be explained later on.

This corrective is really almost entirely abandoned, and is seldom used except in marine chronometers ; in pocket watches it

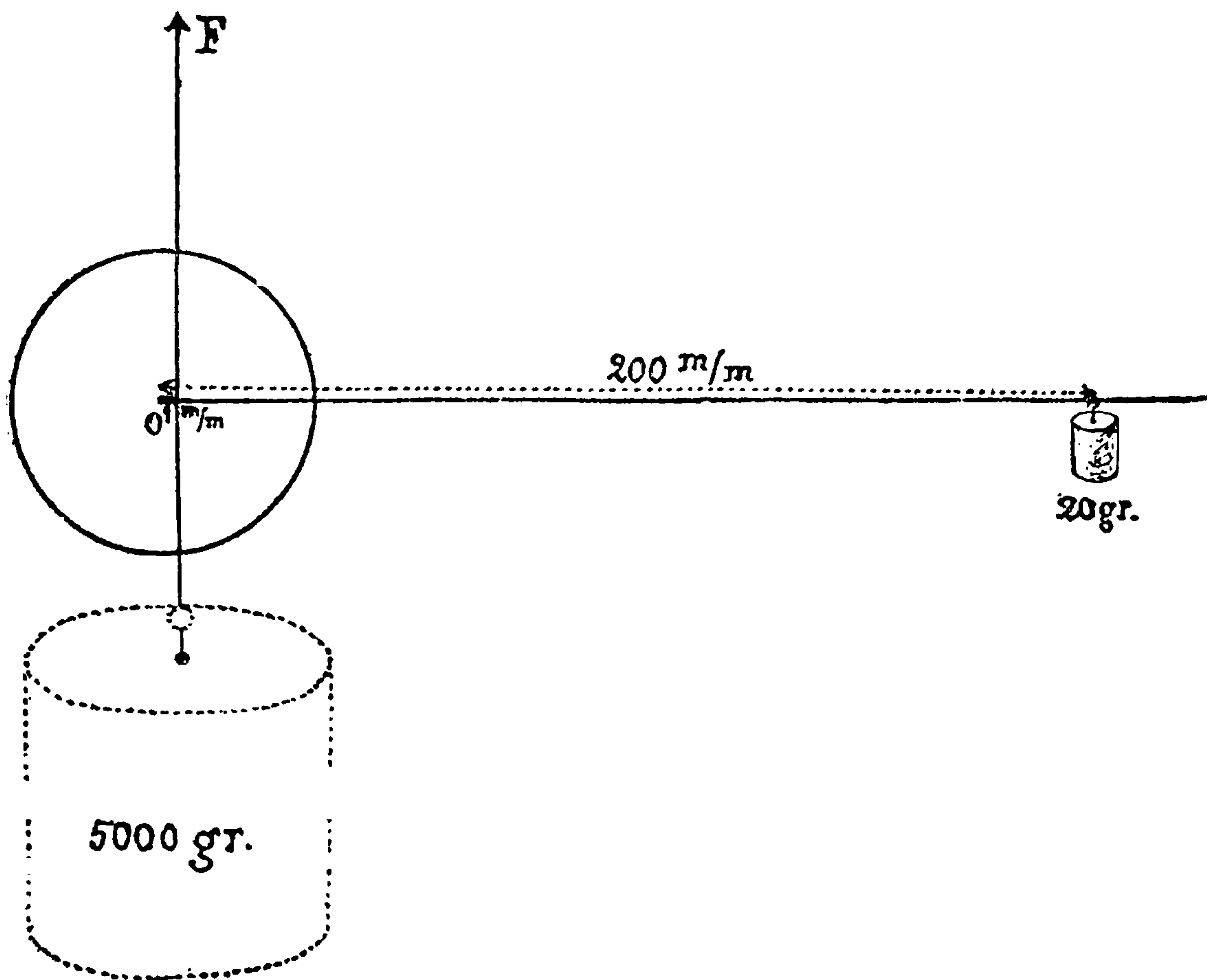

Fig. 14

has become useless in proportion as the improvements in the construction of escapements have come into use, and as the isochronism of the oscillations of the balance wheel has been obtained.

#### Theoretical Study of the Moment of a Spring's Force.

86. Coefficient of Elasticity. When a body receives an exterior effort, the molecules which compose it tend to follow the direction of this force ; they approach each other or separate themselves, the one from the other. The result is a force equal and opposite, which tends to make the displaced molecules recover their former positions.

This property, common to all bodies in different degrees, is called their *elasticity*.



According to the effort exerted, the molecules approach or leave each other; the first case is an effect of compression or contraction, the second is an effect of tension.

**87.** The reaction is always equal to the action; we can then measure the elastic force of bodies by the exterior effort which is applied to them. The following experiment will explain this assertion:

**88.** Let us secure one of the extremities of any vertical rod, to the other extremity we suspend a weight (Fig. 15). This rod from that moment undergoes a certain elongation, and we can prove that the molecular effort developed is equal to the weight producing the elongation. The elongation of this rod will depend on the size of the force  $P$ , on the length of the piece in its natural state, on the cross section of this piece being assumed the same throughout, and finally on the material of which it is composed.

By experimenting on a rubber band we can see that under the action of a force  $P$ , the transverse section of the body diminishes at the same time that the elongation is produced. This regular diminution on almost the entire length of the band does not take place uniformly near the two points of fastening. Therefore, it is necessary to take the elements for the experiment sufficiently removed from these points in order to eliminate a source of error which would influence the final result.

Let us take again, for example, a rod of iron, whose transverse section is 1 square mm.; we have measured the distance between two marked points sufficiently removed from the points of fastening; let  $L$  be this length. We suspend from the lower end of the rod a weight  $P$ , and we measure anew the length between the two marks; we obtain then an elongation  $l$ . Experiments made in this manner have demonstrated that, provided the load  $P$  does not surpass

a certain limit,  $l$  remains proportional to the load.

Supposing now that the experiment were physically possible, let us determine what should be the load  $P$  that could produce an elongation equal to the original length  $L$ . We call this

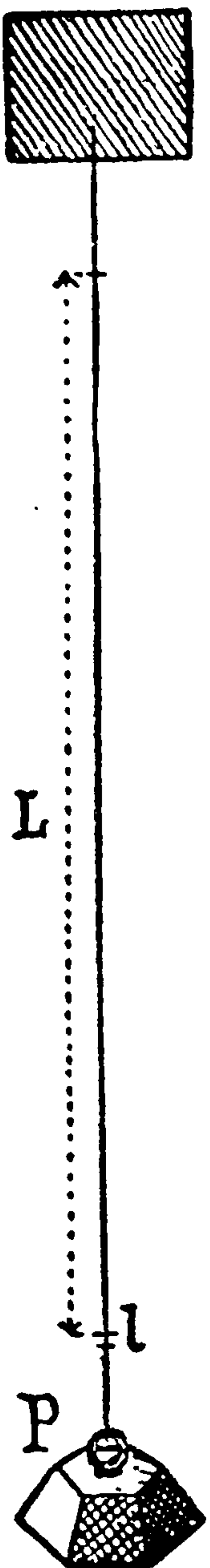

Fig. 15



particular value of  $P$  the *coefficient of elasticity* of the body ; we will designate it by the letter  $E$ .

The elongation being proportional to the load, we have

$$\frac{P}{l} = \frac{E}{L},$$

whence

$$E = \frac{P L}{l}.$$

Thus, in the case of an iron rod, whose original length  $L$  was 1000 millimeters, if we suspended from it a load  $P$  of 1000 grammes, we will find an elongation of 0.05 mm., which gives

$$E = \frac{1000 \times 1000}{0.05} = 20000000 \text{ gr.}$$

as the coefficient of the elasticity of iron.

**89.** The elongation  $l$  is inversely proportional to the transverse section of the body ; thus for a section of surface  $s$  the formula above will become

$$E = \frac{P L}{s l}.$$

**90.** When the coefficient of elasticity is known, it is easy to determine the value of the force exerted by the molecules of a body subjected to the action of an exterior force by the relation

$$P = \frac{E l s}{L}.$$

The fraction  $\frac{l}{L}$  represents the elongation per unit of length ; this fraction should remain very small for this formula to be exact. The quantities  $E$ ,  $s$ ,  $L$  are constant ;  $P$  and  $l$  vary together.

The same formula expresses the relation which connects a force  $P$  of compression to the contraction  $l$ , which results from the action of this force, when the piece compressed does not bend. We will give then to  $P$  and to  $l$  the signs  $+$  and  $-$ ,  $+$  for the forces of tension and the elongations,  $-$  for the forces of compression and the contractions ; the formula then becomes general.

**91. Variation of the Coefficient of Elasticity.** All watchmakers know that after having forged a piece of brass, the elastic force of the metal is increased. In hammering this body one diminishes its volume, but one cannot change its weight ; the molecules which compose the piece are forced together, and the specific weight of the metal will be increased. This simple fact shows us that the coefficient of elasticity of solid bodies should vary with their specific weight.

When a watch (not compensated), regulated to a certain temperature, is exposed to a higher temperature, it loses about



10 seconds in 24 hours for each degree centigrade. The spring is expanded by the effect of the increase of temperature, its molecules are separated from each other; the specific weight of the metal has diminished at the same time as its coefficient of elasticity. The reverse takes place when the watch is observed at a lower temperature than that to which it had been regulated.

It does not appear that the coefficient of elasticity of steel undergoes a great variation by the effect of tempering and that of reheating. A piece of steel in fact changes its dimensions very little by tempering. It has been proven that by tempering in water a piece of steel stretches about  $\frac{3}{1000}$  of its original length, but that this elongation is lost when the piece is reheated to the blue color, the specific weight of the steel not being modified, the coefficient of elasticity retains the same value as that which it possessed before tempering.

92. We give here a table of the coefficients of elasticity of some bodies employed in horology. The figures below are taken from the "Almanac of the Bureau of Longitudes."\*

**Values of the Coefficients of Elasticity, *E*.**

Substance.	Hammer Hardened.	Annealed.
Steel . . . . .	19549	19561
English Steel . . . . .	18809	17278
Creusot Steel {	Very soft . . . . .	20705
	Demi-soft . . . . .	20911
	Hard . . . . .	20599
Silver . . . . .	7358	7146
Bronze : 90 Copper, 10 Tin {	Ordinary . . . . .	7589
	Phosphorous . . . . .	8250
	Laveissiere . . . . .	9061
Copper . . . . .	12449	10519
Berry Iron . . . . .	20972	20794
Brass : {	32 Zinc . . . . .	9277
	68 Copper . . . . .	9395
German Silver : {	18 Zinc . . . . .	10788
	61 Copper . . . . .	
	22 Nickel . . . . .	
Gold . . . . .	8132	5585
Palladium . . . . .	11759	9789
Platinum . . . . .	17044	15518
Iridized Platinum : {	10 Iridium . . . . .	21426
{	90 Platinum . . . . .	
Flat Glass . . . . .		6722
Zinc . . . . .	8735	9292

REMARK—The above values are expressed in kilogrammes; we will always reduce them to grammes whenever we introduce the coefficient of elasticity in our calculations. The coefficient of the extra fine steels employed in horology is generally superior to the value given in the above table. Experience has led us to employ 23000 for its mean value (therefore 23000000 grammes).

\* An almanac published by the astronomers of the Paris Observatory.



**93. Limit of Elasticity.** If we submit any rod to the action of different loads, we note that as long as the load does not exceed a certain limit, proportionate to the transverse section of the body, the rod resumes its original length, after the removal of the weight. By increasing the weight so as to pass this limit, the elongation only partially disappears or perhaps does not disappear at all. This limit is called the "limit of perfect elasticity" of the body con-

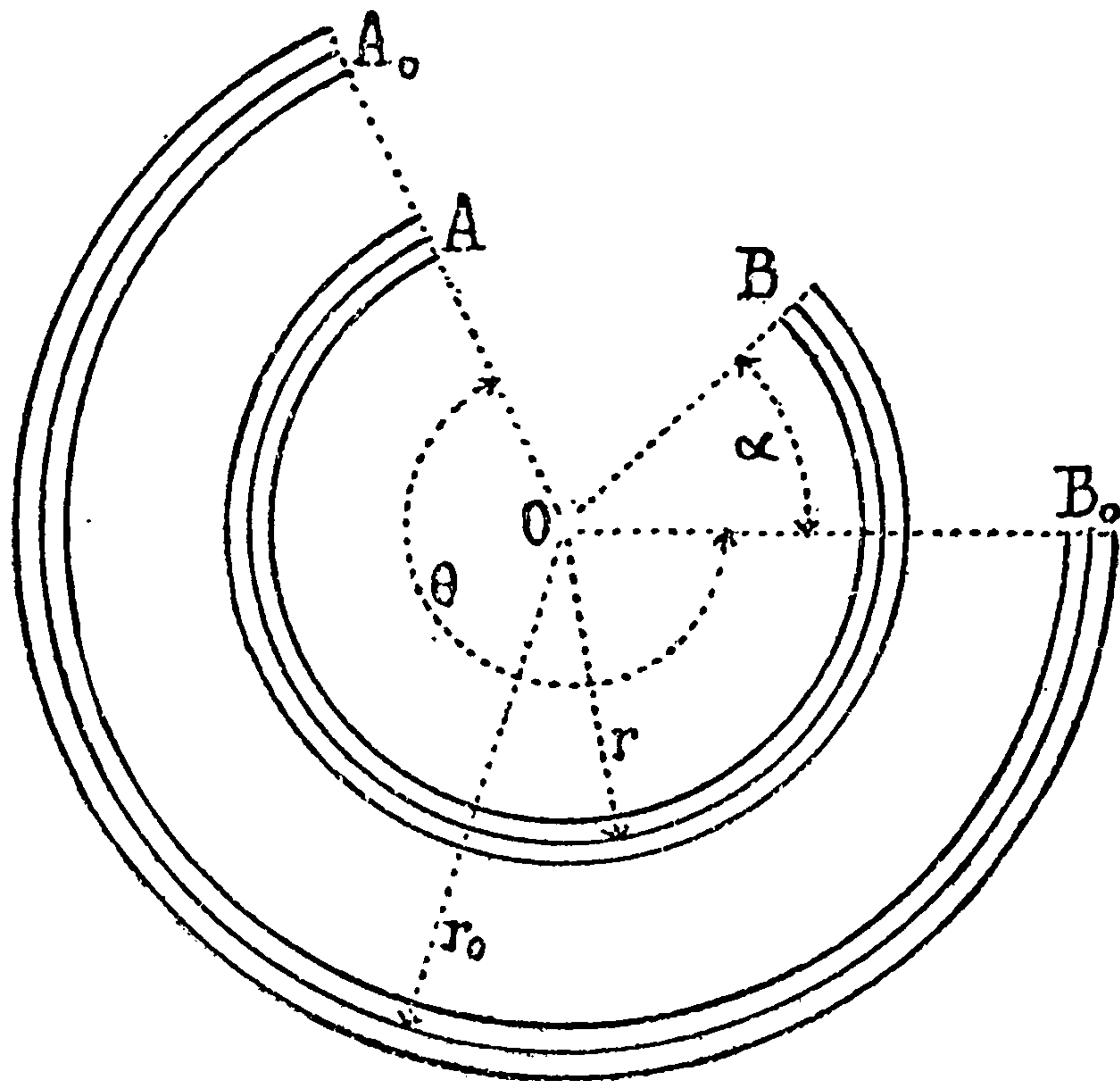

Fig. 16

sidered. If we continue to increase the weight, the elongation becomes more and more apparent and at length a "rupture" is produced.

The limit of perfect elasticity is very slight for certain metals, such as lead, red copper, aluminum, etc. Iron, even, does not possess a very great limit; on the other hand, steel, when it is tempered, increases its limit of elasticity by suitable reheating. This reheating, known under the name of "spring temper," corresponds to the bright blue color.

It would be of great use in horology to know the exact value of this limit of perfect elasticity of hardened and tempered steel; these experiments have not yet been thoroughly studied and the data is consequently lacking. For the present we will confine ourselves to the results with which the practice of horology furnishes us.

**94. Moment of the Elastic Force of a Spring Subjected to a Flexion.** Let  $A_0 B_0$  be a spring of circular form, of rectangular



section, of thickness  $e$  and height  $h$ . Let us imagine that this blade of spring be divided in the direction of its length into a certain number of fibres, one of which, especially, situated in the middle of the body, is called the "neutral fibre" for the reason that it does not change its length when the spring undergoes a flexion. When this blade is bent in such a way that the radius of the neutral fibre diminishes (Fig. 16), the fibres interior to this undergo a shortening, while the exterior fibres are lengthened.

Let  $\pm v$  be the distance of any fibre from the neutral fibre.  $+v$  if the fibre is on the exterior and  $-v$  if it is on the interior of the neutral fibre. If  $r_0$  represents the radius of the neutral fibre in the unchanged position and  $\theta$  the angle that the two radii ending at the extremities  $A_0$  and  $B_0$ , form between them, we will have the length  $L_0$  of the neutral fibre by the equation

$$L_0 = r_0 \theta$$

and the length  $L'_0$  of any fibre whatever whose radius is  $r_0 + v$  will be

$$L'_0 = (r_0 + v) \theta.$$

If now, one of the extremities of the blade is fastened and we bend the other, making it traverse an angle  $\pm \alpha$ , the radius of the neutral fibre will diminish if  $\alpha$  is positive, that is to say, if it adds to the angle  $\theta$ . If, on the contrary, the extremity  $B_0$  is bent in the opposite direction, the angle  $\theta$  becomes smaller and we have in this case  $\alpha$  negative: the radius of the neutral fibre will increase.

The length  $L_0$  of this fibre has not changed by the flexion; we will have then in this new position,  $r$  being the radius of the changed position of the fibre,

$$L_0 = r (\theta + \alpha),$$

we then have

$$r_0 \theta = r (\theta + \alpha),$$

from whence

$$r = \frac{r_0 \theta}{\theta + \alpha}$$

The fibre taken whose length is  $L'_0$  has become

$$L'_0 = (r + v) (\theta + \alpha).$$

Replacing  $r$  by the value above, we will have

$$L'_0 = \left( \frac{r_0 \theta}{\theta + \alpha} + v \right) (\theta + \alpha),$$

and in working out

$$L'_0 = r_0 \theta + v \theta + v \alpha$$





**THIS PAGE IS LOCKED TO FREE MEMBERS**

Purchase full membership to immediately unlock this page

# HISTORY

Tens of thousands of important historical sources, many previously unobtainable, are now available for the first time with a Forgotten Books Full Membership.

Unlimited Access  
\$8.99/month

**Continue**

\*Fair usage policy applies





Replacing in the equation (3),  $P$ , by its value (2) we will have

$$(4) \quad M P = 2 \frac{E a s v^2}{L}.$$

Let us now regard the section  $s$ , of the fibres considered.

The cross section of the spring being imagined rectangular, of height  $h$  and thickness  $e$  we will have, supposing first that the blade

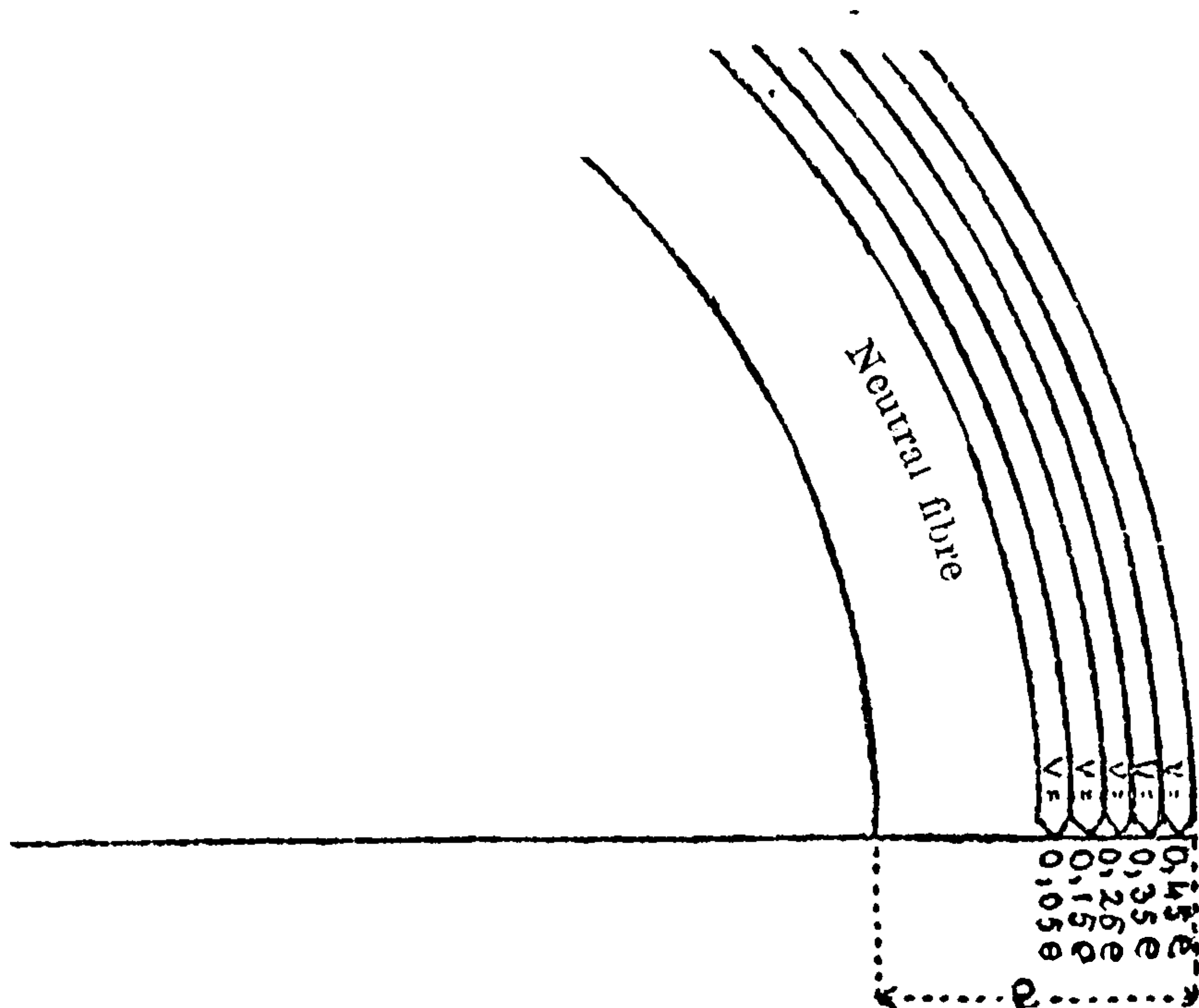

Fig. 17

is divided into a definite number of fibres, 10 for example, the section of one of these fibres

$$s = 0.1 e \times h,$$

since the thickness of one fibre will be in this case the tenth part of the total thickness of the spring.

Let us admit, what is not absolutely exact, that each separate fibre acts through its middle part, that is to say, that the distance  $v$  from the middle of the fibre nearest to the neutral fibre be  $0.05 e$  (Fig. 17), the distance of the middle of the second  $0.15 e$ , that of the third  $0.25 e$ , for the fourth  $0.35 e$  and then for the fifth  $0.45 e$ .

Since in the equation (4) the term  $v$  is to the second power we should raise each of the five preceding values to the square and find the sum of them. We will then have

1st fibre	$v = 0.05 e$	.	.	.	.	$v^2 = 0.05^2 e^2 = 0.0025 e^2$
2d	$v = 0.15 e$	.	.	.	.	$v^2 = 0.15^2 e^2 = 0.0225 e^2$
3d	$v = 0.25 e$	.	.	.	.	$v^2 = 0.25^2 e^2 = 0.0625 e^2$
4th	$v = 0.35 e$	.	.	.	.	$v^2 = 0.35^2 e^2 = 0.1225 e^2$
5th	$v = 0.45 e$	.	.	.	.	$v^2 = 0.45^2 e^2 = 0.2025 e^2$

$$\text{The sum of } v^2 = 0.4125 e^2$$



Replacing now the values determined of  $s$  and of  $v^2$  in the equation (4) we will have

$$\text{Sum } M P = 2 \frac{E \alpha \cdot 0.1 e h \cdot 0.4125 e^2}{L}.$$

This formula represents the moment of the force of all the ten fibres considered, therefore of the entire spring, while the formula (4) gave the value of the moment of two fibres only, the one interior and the other exterior, to the neutral fibre. Designating by  $F$  the preceding sum, we will have, by performing the operations indicated

$$(5) \quad F = \frac{0.0825 E e^3 h \alpha}{L}.$$

We have obtained the coefficient 0.0825 by dividing the blade of the spring into 10 fibres; if we had supposed it divided into a very large number of fibres, we would have arrived at a value very nearly approaching 0.08333, say,  $\frac{1}{12}$ . We would have then in this case.

$$(6) \quad F = \frac{E e^3 h \alpha}{12 L}.$$

96. We have arrived at this last form, which is the exact one, only by approximation.

Integral calculus furnishes us a means of effecting the above calculation with an absolute exactitude and for an infinite number of fibres. (\*)

Let us take up again the equation (4)

$$M P = \frac{E \alpha s v^2}{L}.$$

Designating the infinitely small thickness of a fibre by  $d v$ , we will have for the section  $s$

$$s = d v \cdot h;$$

on replacing

$$d. M P = 2 \frac{E \alpha h}{L} v^2 d v,$$

or

$$\int d. M P = 2 \frac{E \alpha h}{L} \int v^2 d v.$$

We will place

$$\int d M P = F$$

and we will have

$$F = 2 \frac{E h \alpha}{L} \int v^2 d v = \frac{2}{3} \frac{E \alpha h}{L} v^3 + C.$$

(\*) We give below this second manner of calculating the moment of the force of a spring; This calculation, as also all that is written in fine print in this treatise, can be omitted by all persons unaccustomed to the infinitesimal calculus.



Replacing  $v$  by  $\frac{1}{2} e$ , that is to say, taking the integral between the limits  $v = \frac{1}{2} e$  and  $v = 0$ , we will obtain

$$F = \frac{1}{12} \frac{E h e^3}{L} \alpha.$$

97. In the preceding formula,  $\alpha$  is the angle which we have made the free extremity of the spring describe from the position where the elastic effort is null, to the point which we wished to study. Thus, when we have turned the free extremity of the spring one revolution, the original number of revolutions will be increased by 1, etc. We can then estimate the angle  $\alpha$  by counting the number of turns which the spring is wound up at the moment considered, not forgetting to deduct from this figure the number of turns which the spring makes if placed unconfined on a table. Let  $n$  be this difference, we will have

$$\alpha = 2 \pi n;$$

we can write the formula (6)

$$(7) \quad F = \frac{E h e^3 2 \pi n}{12 L}.$$

98. On calculating the moment of the force of a barrel spring by means of this equation, and on then comparing the result obtained with that which the experiment gives (83), we generally find a slight difference. This difference proceeds essentially from the following causes :

1st. As we have already stated, the value of the coefficient of elasticity of the spring with which we are engaged could be perceptibly different from that which we have admitted in the calculation.

2d. It is difficult to measure exactly the thickness of the spring : a slight error will give a considerable difference in the result. Thus, for a spring of 0.18 mm. an error of  $\frac{1}{100}$  of a millimeter will influence the result one-sixth.

3d. The transverse section of the blade is rarely a perfect rectangle ; the spring is often concave on the outside and convex on the inside.

4th. The calculation supposes the spring to be perfectly free, but complicated effects are produced when it is shut up in the barrel.

When it is wound around the hub of the arbor there is only a certain length of the blade which is freed from the coils pressed against the drum of the barrel. The moment of the force should therefore be calculated according to the length of the blade freed.



5th. When the spring is wound up to a certain point, the coils of which it is composed deviate from the circular form and spread out to one side ; there is thus produced a decomposition of force, one of the components of which is directed towards the center of the barrel and is transformed into friction. We can add a similar defect which is produced at the center and which on combining with the exterior fault can diminish, or, in certain cases, increase the moment of the force of the spring.

6th. Considerable friction is produced between the coils of the spring ; the oil which we are obliged to use to reduce friction produces a slight effect by its adhesive force.

**99. Example for the Numerical Calculation of the Formula (7).** The dimensions of the spring for a watch 43 mm. diameter (19 lines) being the following :

Thickness,  $e$ , = 0.18 mm.  
 Height,  $h$ , = 3.6 mm.  
 Length,  $L$ , = 650 mm.

to calculate the moment of the force of this spring.

When the elastic effort of this spring is nothing, that is to say, when it is placed perfectly free on a table, it makes 5 turns. Coiled in the interior of the barrel and pressing against the drum, it makes 14. The development of this spring being 6 turns in the barrel, a half turn is given for safety, and we will have, according to what has been said,

$$n = 14 + 5.5 - 5 = 14.5 \text{ turns,}$$

when the watch is completely wound up.

Let us take the coefficient of elasticity,  $E = 23000000$ . The formula (7) can be written thus :

$$F = \frac{E h e^3 \pi n}{6 L};$$

replacing the letters by their values, we have

$$F = \frac{23000000 \times 3.6 \times 0.18^3 \times 3.1416 \times 14.5}{6 \times 650}.$$

Effecting the above calculations we find that

$$F = 5640 \text{ gr.}$$

for  $n = 14.5$  turns.



The simplest way of effecting the above calculation is by means of logarithms. We give below the method of such an operation :

$$\begin{array}{r}
 \text{Log. } E = \log. 23000000 = 7.3617278 \\
 + \log. e^3 = \log. 0.18^3 = 0.7658175 - 3 \\
 + \log. h = \log. 3.6 = 0.5563025 \\
 + \log. \pi = \log. 3.1416 = 0.4971499 \\
 \hline
 \text{Log. numerator} \quad 6.1809977. \\
 \\
 \text{Log. } L = \log. 650 = 2.8129134 \\
 + \quad \quad \log. 6 = 0.7781513 \\
 \hline
 \text{Log. denominator} \quad 3.5910647. \\
 \\
 \text{Log. numerator} \quad 6.1809977 \\
 - \text{log. denominator} \quad 3.5910647 \\
 \hline
 2.5899330 = \log. 388.985. \\
 + \log. n = \log. 14.5 = 1.1613680 \\
 \hline
 3.7513010 = \log. 5640.
 \end{array}$$

The preceding calculation shows that the moment of the force of the spring is 388.985 gr. for a number  $n = 1$ . For  $n = 14.5$  it is 5640 gr. When, on account of the running of the watch, the barrel has made one turn,  $n$  will have diminished one unit and will only have 13.5 as value ; the moment of the force of the spring will have diminished 388.985 gr., or, in round numbers, 389 gr. We can then form the following table :

$F$	for $n = 14.5 = 5640$ ,	the spring is entirely wound up.
$F_1$	“ $n = 13.5 = 5251$ ,	the barrel has made one turn.
$F_2$	“ $n = 12.5 = 4862$ ,	the barrel has made two turns.
$F_3$	“ $n = 11.5 = 4473$ ,	the barrel has made three turns.
$F_4$	“ $n = 10.5 = 4084$ ,	the barrel has made four turns.

**100. Inequality of the Elastic Force of the Spring.** The moment  $F$  of the force of a spring is then greater when the watch is completely wound than when it is about to stop. This fact has been already demonstrated to us by experiments (84).

It is necessary to confine this inequality of the motive force within the narrowest limits possible. Let us note for this purpose that in the numerical calculation of the formula (7) we have successively replaced  $n$  by  $n - 1$ ,  $n - 2$ ,  $n - 3$ , and  $n - 4$  ; in this last case the watch is at the instant when it is about to stop, if the barrel is furnished with stop works. But the ratio between  $n$  and  $n - 4$  being greater as  $n$  is smaller, it will be proper, in order to diminish the inequality of the force, to give to the number of turns,  $n$ , of



the spring, as great a value as possible. The following demonstration will better explain this idea.

101. Since we can use springs producing the same initial moment of force  $F_0$ , but whose dimensions and number of turns,  $n$ , are different, we understand that  $F_4$  may vary in certain cases much less than in others.

Let us suppose, for example, two springs producing, when wound up, the same moment of force  $F_0 = 4000$ ; the first having a number of turns  $n = 10$ , the second a number  $n = 20$ . For the first we would have in the formula (7) the value

$$\frac{1}{12} \frac{E e^3 h 2 \pi}{L} = 400,$$

and for the second this same value will be

$$\frac{1}{12} \frac{E e^3 h 2 \pi}{L} = 200.$$

When the two barrels will have executed one revolution, the number of turns of the first will be  $n_1 = 9$  and that of second  $n_1 = 19$ . We will then have successively :

First Case.		Second Case.
$F_0 = 400 \times 10 = 4000$		$F_0 = 200 \times 20 = 4000$
$F_1 = 400 \times 9 = 3600$		$F_1 = 200 \times 19 = 3800$
$F_2 = 400 \times 8 = 3200$		$F_2 = 200 \times 18 = 3600$
$F_3 = 400 \times 7 = 2800$		$F_3 = 200 \times 17 = 3400$
$F_4 = 400 \times 6 = 2400$		$F_4 = 200 \times 16 = 3200$

It is thus easy to see that the moment of the force diminishes in the first case much more rapidly than in the second, and that the force of the second spring approaches much more a constant value than that of the first.

It is best, then, to give to the number of turns,  $n$ , the greatest value possible.

For a given spring this number cannot, however, exceed a certain value determined by the limit of perfect elasticity of the steel, which cannot be exceeded without setting or breaking the spring.

This limit depends on the elongation per unit of length  $\frac{l}{L}$  of the exterior fibre. We have had (94)

$$l = v a$$

which can be written

$$\frac{l}{L} = \frac{v a}{L}.$$



In the preceding numerical example we have had the following values :

$$v = \frac{1}{2} e = 0.09, \quad \alpha = 2 \pi n = 14.5 \times 2 \pi, \quad L = 650 \text{ mm.}$$

We will then have

$$\frac{l}{L} = \frac{0.09 \times 14.5 \times 2 \pi}{650},$$

and on performing the calculations

$$\frac{l}{L} = 0.012614 \text{ mm.}$$

We can admit this value of  $\frac{l}{L}$  as the limit allowing sufficient security, and established by practice.

**102.** It must not be forgotten, however, that the nature of the steel, the manner in which the springs are manufactured, hardened and tempered, can materially modify this limit.

The springs are hardened and tempered in circular form, with about 100 mm. radius ; they are then worked in a spring tool and by this operation the fibres undergo quite an unequal elongation, since, from the first circular form, they pass to a spiral form whose radii of curvature for the interior coils are much smaller than those for the exterior coils.

It follows, from this operation, that the exterior fibres are elongated more in the inner coils than in the outer ones. It is for this reason that the springs break more often interiorly than exteriorly.

**103.** The form which a spring has on leaving the hands of the maker is very variable and it can be with difficulty represented by a general equation.

This primitive form is not preserved after the watch has run a certain time : the spring “ gives ” a little at first and finally ends by taking a form which it keeps permanently. This last form is the one which should be taken as the starting point from which to determine the angle  $2 \pi n$  giving the degree of flexion in the formula (7). Starting from this position, we can admit that the elongation per unit of weight  $\frac{l}{L}$  is much the same for the whole length of the spring.

**104. Length of the Spring.** Since we cannot unfold a spring, in order to measure its length, without modifying its interior structure, it is convenient to have at our disposal a simple formula enabling us to calculate the value  $L$ .

Supposing the spring coiled in the interior of the barrel ; we will admit that the radius extending to the interior coils may be





**THIS PAGE IS LOCKED TO FREE MEMBERS**

Purchase full membership to immediately unlock this page

# DELVE INTO FANTASY, MAGIC, MYTHOLOGY & FOLKLORE

Forgotten Books'  
Full Membership gives  
access to 797,885 ancient  
and modern, fiction and  
non-fiction books.

**Continue**

\*Fair usage policy applies



Let  $N'$ , be the number of coils which the spring makes when it is pressed against the side of the barrel ;  $N''$  the number of coils when wound around the hub. We will have then  $N = N'' - N'$ .

In order to simplify the calculations, let us neglect the inner and outer ends of the blade which are disengaged from the coils, and

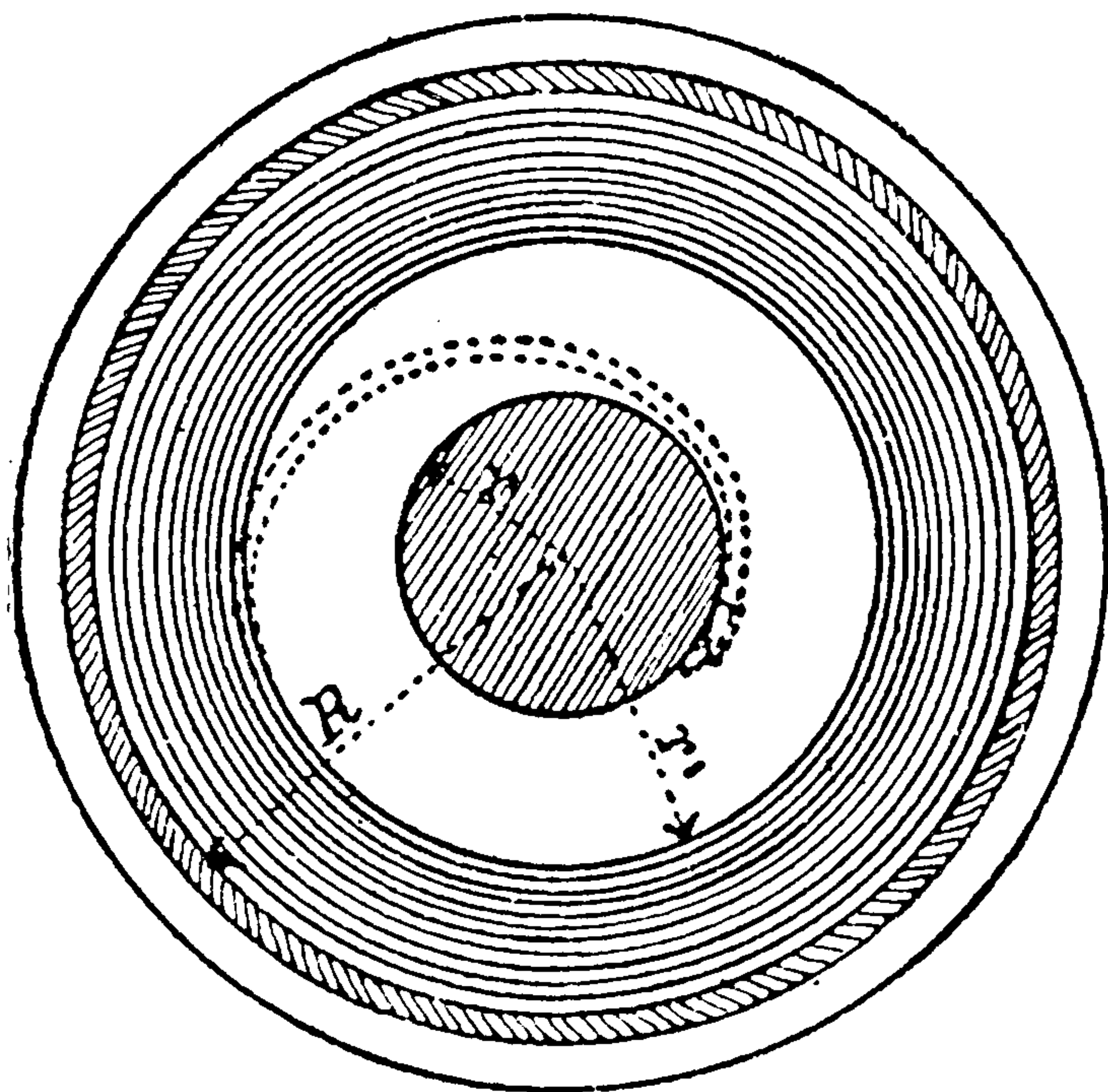

Fig. 18

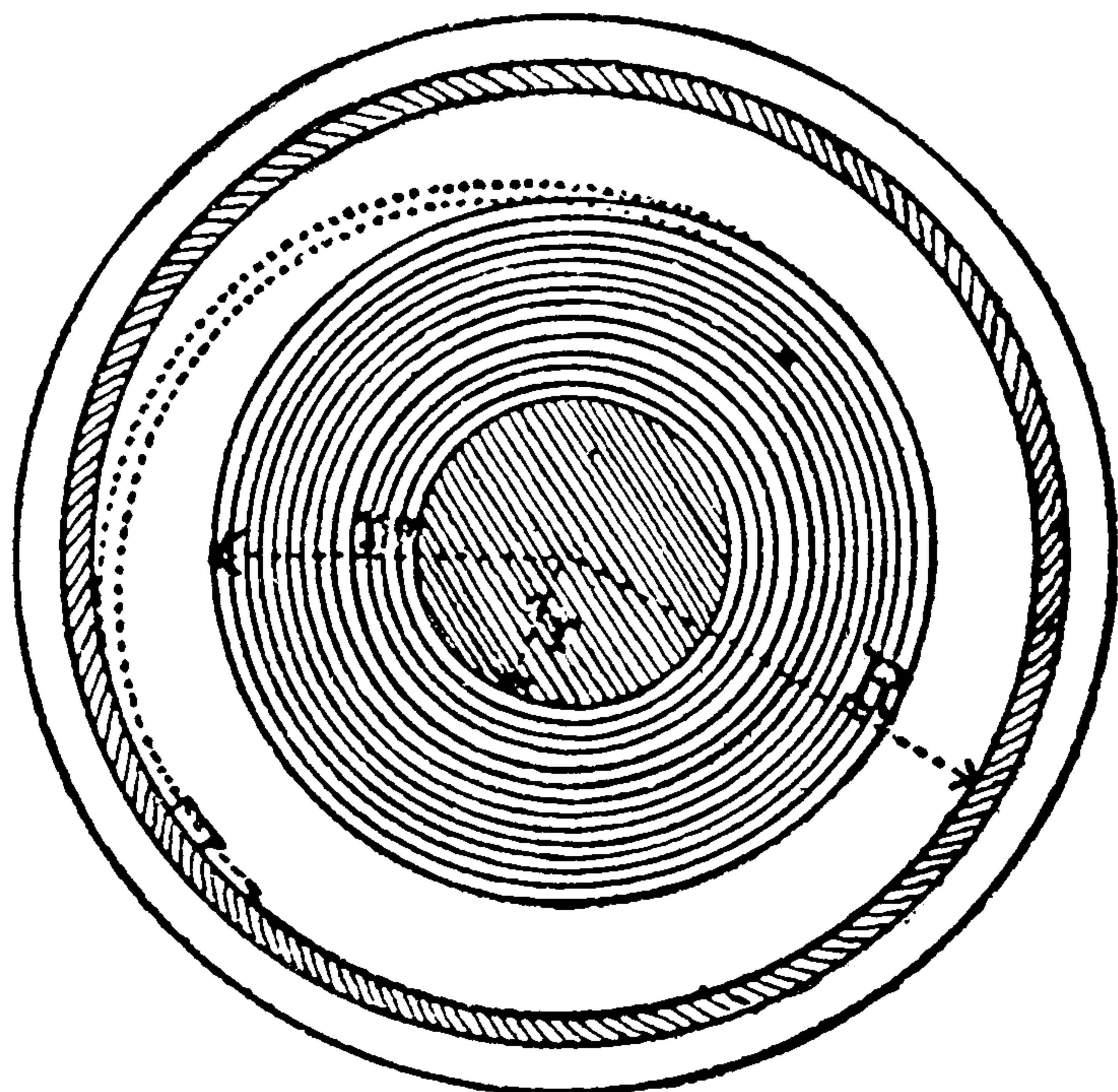

Fig 19.

admit that the space occupied by the spring in the two positions is a cylindrical volume. Let us designate, moreover by

$R$ , the interior radius of the barrel ;

$r$ , the radius of the hub ;

$r'$ , the radius extending to the interior coil of the spring when it is pressed against the side of the barrel (Fig. 18) ;

$r''$ , the radius extending to the outer coil of the spring when it is wound around the hub (Fig. 19) ;

$e$ , the thickness of the spring.

We can write

$$N'' = \frac{r'' - r}{e} \text{ and } N' = \frac{R - r'}{e},$$

and consequently

$$(1) \quad N = N'' - N' = \frac{r'' - r}{e} - \frac{R - r'}{e}.$$

We can find the value of  $r''$  in functions of  $R$ ,  $r'$  and  $r$  on observing that the surfaces occupied by the spring in the two positions are equivalent.

When it is pressed against the side of the barrel, this surface is

$$S = \pi (R^2 - r'^2),$$



and when it is wound around the hub

$$S = \pi (r'^2 - r^2).$$

Therefore,

$$r'^2 - r^2 = R^2 - r'^2,$$

from whence

$$r'' = \sqrt{R^2 - r'^2 + r^2}.$$

Substituting this value of  $r''$  in the equation (1), we have

$$(2) \quad N = \frac{1}{e} \left( \sqrt{R^2 - r'^2 + r^2} - r - R + r' \right).$$

106. Let us note that when we obtain the value of  $e$  in the equation

$$N' = \frac{R - r'}{e}$$

we find that it differs from the real value, which is always less. This difference arises from the fact that on account of certain inequalities of the spring, the coils of the blade do not strictly superpose.

107. **Maximum of  $N$  in Terms of  $r'$ .** The equation (2) indicates that for a barrel whose interior radius  $R$ , the radius of the hub  $r$  and the thickness of the spring  $e$ , are determined, the number of turns of development  $N$  varies with the radius  $r'$  extending to the first inner coil of the spring in its state of rest. This last radius,  $r'$ , depends on the length of the blade.

Let us apply, in the first place, this formula to a numerical example and use the following data :

Interior radius of the barrel . . .	$R =$	$3$
Radius of the hub . . . . .	$r =$	$1$
Fraction $\frac{1}{e}$ . . . . .	$=$	$13.$

The equation (2) will become, after replacing the known quantities by their values,

$$N = 13 \left( \sqrt{9 + 1 - r'^2} - 1 - 3 + r' \right),$$

or

$$N = 13 \left( \sqrt{10 - r'^2} - 4 + r' \right).$$

The smallest value that the radius  $r'$  can have is

$$r' = r = 1$$

and its greatest value may be

$$r' = R = 3.$$

In the first case the spring has a number of coils sufficient to completely fill the space between the side of the barrel and the hub, and in the second this number of coils is nothing. The reasoning shows



that in these two extreme cases the development of the spring would be nothing, which the application of the formula (2) also proves.

Replacing successively in this same formula  $r'$  by 1.1, 1.2, 1.3, etc., up to 2.9, we can form the following table :

$r'$	$N$	$r'$	$N$	$r'$	$N$
1	0	1.7	4.76	2.4	5.96
1.1	0.84	1.8	5.2	2.5	5.67
1.2	1.63	1.9	5.56	2.6	5.2
1.3	2.37	2	5.84	2.7	4.5
1.4	3.06	2.1	6.03	2.8	3.5
1.5	3.69	2.2	6.13	2.9	2.09
1.6	4.26	2.3	6.11	3	0

One sees that the maximum number of coils in the development of the spring is given by a radius  $r'$  equal to about 2.2.

In practice,  $\frac{2}{3}$  of  $R$  has been adopted as the value of  $r'$  for the reason that the regularity of the power from beginning to end increases with the length of the spring.

**108.** The calculus enables one to determine the exact value of the maximum of  $N$  in function of  $r'$ .

Let us take up again the equation (2) :

$$N = \frac{1}{e} (\sqrt{R^2 - r'^2 + r^2} - r - R + r'),$$

in which the two variables are  $N$  and  $r'$ . Let us differentiate this equation by placing

$$R^2 - r'^2 + r^2 = z,$$

we will have

$$dz = -2r' dr'$$

and

$$dN = \frac{1}{e} \left( \frac{1}{2} z^{-\frac{1}{2}} dz + dr' \right),$$

Replacing  $z$  and  $dz$  by their values, it becomes

$$dN = \frac{1}{e} \left( \frac{-r' dr'}{\sqrt{R^2 - r'^2 + r^2}} + dr' \right),$$

$$\text{or } \frac{dN}{dr'} = \frac{1}{e} \left( \frac{r'}{\sqrt{R^2 - r'^2 + r^2}} + 1 \right);$$



equating this derivative to zero :

$$\frac{1}{e} \left( - \frac{r'}{\sqrt{R^2 - r'^2 + r^2}} + 1 \right) = 0,$$

which gives

$$\frac{r'}{\sqrt{R^2 - r'^2 + r^2}} = 1,$$

and

$$r' = \pm \sqrt{R^2 - r'^2 + r^2}.$$

Raising to the square we have

$$r'^2 = R^2 - r'^2 + r^2$$

and

$$(3) \quad r' = \sqrt{\frac{R^2 + r^2}{2}},$$

Substituting this value of  $r'$  in the equation

$$r'' \sqrt{R^2 - r'^2 + r^2}$$

we will have

$$r'' = \sqrt{R^2 - \frac{R^2 + r^2}{2} + r^2} = \sqrt{\frac{R^2 + r^2}{2}}.$$

We see that the maximum of  $N$  occurs when one has

$$(4) \quad r' = r'' = \sqrt{\frac{R^2 + r^2}{2}},$$

Since it is the custom, in practice, to make the radius of the hub equal to one-third of the interior radius of the barrel, we can place

$$R = 3 \text{ and } r = 1$$

and we will have

$$r' = r'' = \sqrt{\frac{9 + 1}{2}} = \sqrt{5} = 2.236.$$

**109.** In order to represent graphically, the equation (2), let us refer it to two rectangular coördinate axes (Fig. 20) and lay off on the axis of the abscissa the values of  $r'$ , and on the axis of the ordinate the corresponding values of  $N$ , and connect the points thus obtained by a curved line.

One sees that on making the unoccupied space of the barrel equal to the part occupied by the spring one does not obtain the maximum turns of development of the spring.

**110.** If one divides the interior of the barrel, giving

$\frac{1}{3} R$  to the part occupied by the spring,

$\frac{1}{3} R$  for the empty space,

$\frac{1}{3} R$  for the radius of the hub,

one has

$$N = \frac{1}{e} (\sqrt{3^2 - 2^2 + 1} - 1 - 3 + 2)$$



and

$$N = \frac{1}{e} (\sqrt{6} - 2) = \frac{1}{e} (2.44 - 2) = \frac{1}{e} \times 0.44.*$$

Consequently, if

$$\begin{aligned} \frac{1}{e} = 13 & \text{ one will have } N = 5.7 \text{ turns} \\ \frac{1}{e} = 14 & \text{ " " " } N = 6.1 \text{ " } \\ \frac{1}{e} = 15 & \text{ " " " } N = 6.6 \text{ " } \end{aligned}$$

**111. Diameter of the Hub.** The custom of making the radius

81.

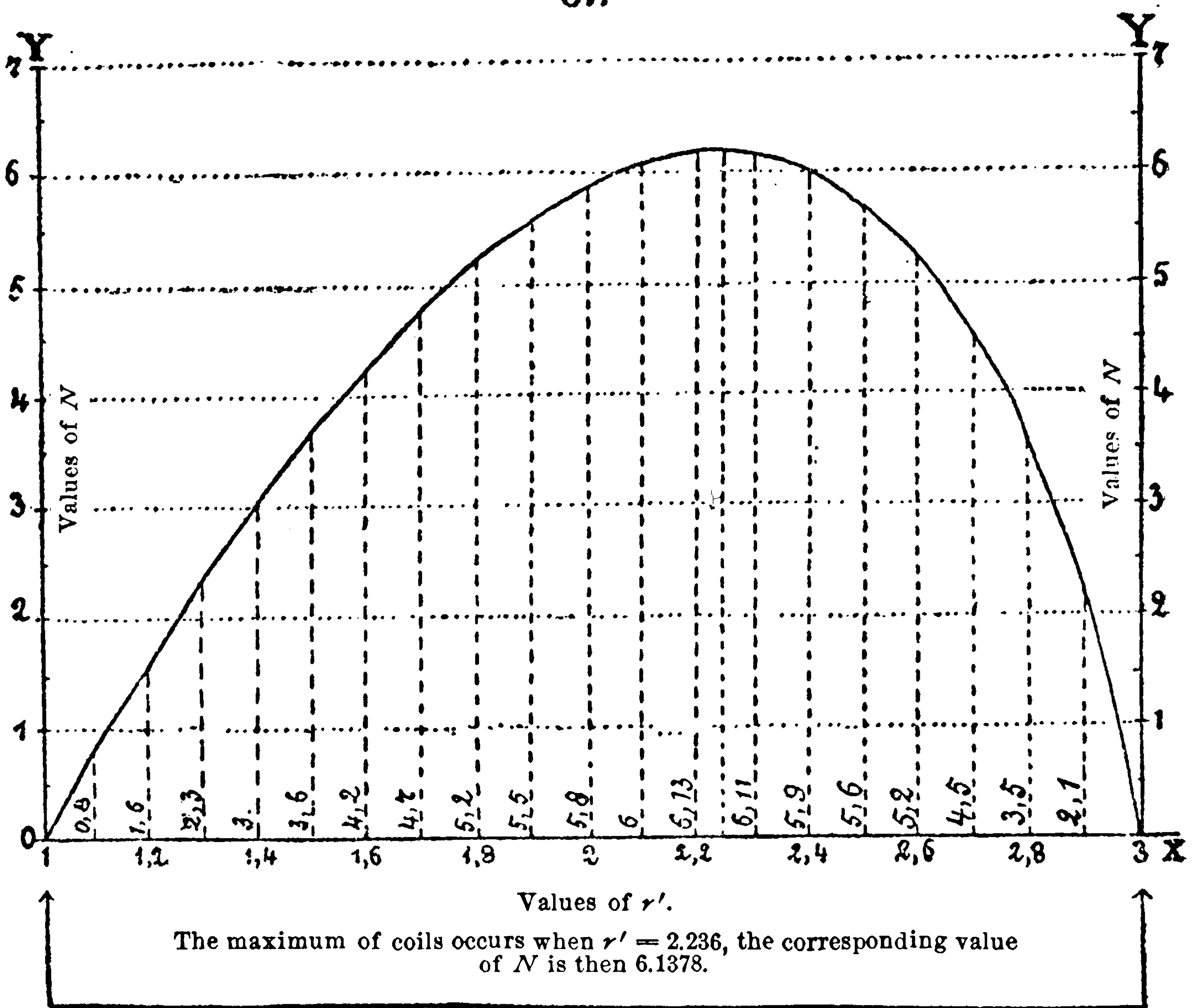

Fig. 20

of the hub equal to one-third of the interior radius of the barrel has been established by long practice. When one leaves the hub greater than this value, one does not obtain a sufficient number of turns of development of the spring, and when one makes it smaller the spring is apt to break, or if it is too much reduced in temper it

\*It is best not to extend the figures of the square root of 6, because on account of the interior part of the spring being attached to the hub, one therefore loses more readily a little of the development.



may "set." Cases present themselves, however, where, in a given barrel, one desires to introduce a thinner spring than that which one has been in the habit of using and it may then be asked if one could not reduce the diameter of the hub, in order to obtain a greater development of the spring. Let us then examine this question.

It is known that when one submits a rod of steel to a tension, the transverse section being equal to one square millimeter, this rod lengthens, and that when the load which produces this elongation reaches a certain value, a rupture is produced. Now, experiments made with spring wire have demonstrated that the wire breaks if the weight reaches a value of 135 kilogrammes.

Let us note that the wire which was used for this experiment was not hardened.

Let us first seek again the elongation  $l$  per unit of length which the rod underwent at the instant immediately preceding the rupture.

We have (88)

$$P = \frac{E l}{L}$$

Taking  $E = 23000000$ ,  $P = 135000$  gr.,  $L = 1$ , we will place

$$l = \frac{135000}{23000000} = \frac{135}{230000},$$

whence

$$l = 0.0058695 \text{ mm.}$$

On the other hand, let us calculate the elongation of the exterior fibre of a barrel spring as it is admitted in practice and compare the two results. For this purpose let us take the spring of a watch of 43 mm. (19 lines) which has furnished proof of being able to bear the desired flexion.

We will have the elongation per unit of length from the formula (94)

$$l = \frac{v a}{L},$$

The thickness of this spring is 0.18 mm., consequently

$$v = 0.09 \text{ mm.}$$

In the interior of the barrel and pressed against the drum this spring had 13 turns and 5 outside of the barrel; moreover, after being wound, it was set up 5.5 turns. With this information we find

$$a = (13 - 5 + 5.5) \times 2 \pi = 27 \pi.$$



The length of the spring is 600 mm.; one will have consequently

$$l = \frac{0.09 \times 27 \times 3.1416}{600} = 0.01272.$$

Comparing the above figures,

$$\begin{aligned} \text{elongation by tension, } l &= 0.0058695, \\ \text{elongation by flexion, } l &= 0.01272, \end{aligned}$$

we can establish the astonishing result that the exterior fibres of a spring can sustain an elongation per unit of length twice as great as that which produces a rupture by tension.

This fact cannot be explained by the supposition of a superior quality of steel to that of the metal composing the rod which broke under the action of a weight of 135 kilog.; because this last steel was certainly of the first quality. It must then be admitted that the exterior fibre of a spring does not break, when the elongation that it acquires is equal to that which produces rupture by tension, for the reason that it is retained by the interior fibres.

In the presence of this fact one can admit as the limit of elongation that the exterior fibre of a spring can bear without breaking, the value

$$l = 0.012 \text{ mm.}$$

One remains within this limit in making the diameter of the hub equal to one-third of the interior diameter of the barrel and in using a spring making 13 turns in one-third of the interior radius of this same barrel.

When one desires to use a thicker or thinner spring, one must in this case determine the diameter of the hub with relation to the thickness chosen. Thus the interior diameter of the barrel which we have used in the preceding experiment being 17.4 mm., the diameter of the hub was then

$$\frac{17.4}{3} = 5.8 \text{ mm.}$$

Dividing this diameter by the thickness of the spring 0.18 one arrives at the conclusion that the diameter of the hub should be 32 times the thickness of the spring, in round numbers. If the diameter of the hub is smaller than this proportion, the spring runs the risk of breaking or, if it is too soft, of setting.

#### **Work Produced by a Spring.**

**112.** One determines the mechanical work which a spring produces at each oscillation of the balance wheel, by dividing the work





**THIS PAGE IS LOCKED TO FREE MEMBERS**

Purchase full membership to immediately unlock this page



# HISTORY

Tens of thousands of important historical sources, many previously unobtainable, are now available for the first time with a Forgotten Books Full Membership.

Unlimited Access  
\$8.99/month

**Continue**

\*Fair usage policy applies



sectional revolution is very nearly parabolic, and whose surface is grooved with a helicoidal curve. This piece is mounted on the axis of a toothed wheel *A* (Fig. 21) gearing with the pinion of the center wheel. The teeth of the barrel are, in this case, suppressed, and its arbor remains constantly fixed.

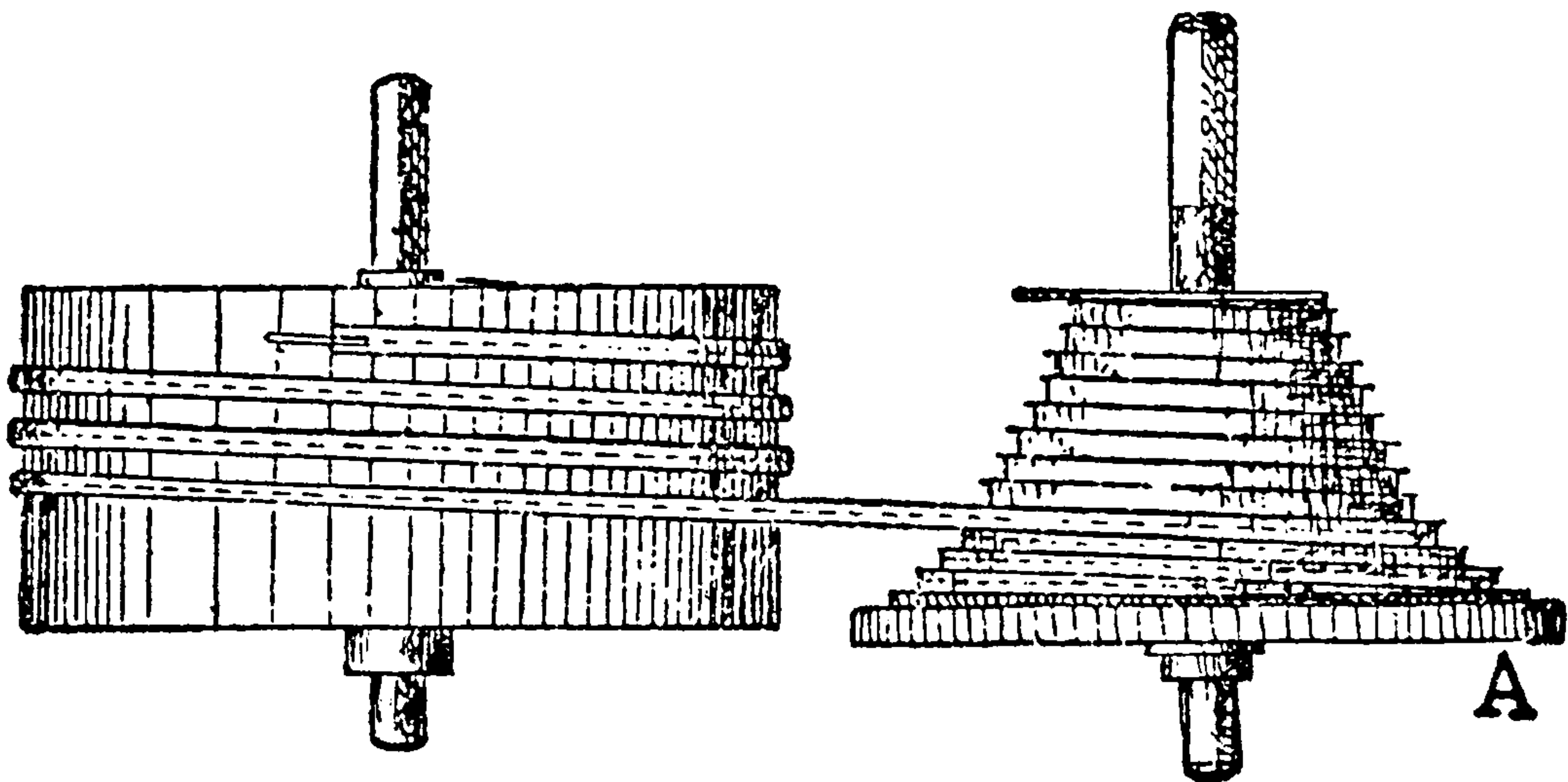

Fig. 21

This arrangement permits of the complete equalization of the motive action of the spring. In effect, when one has just wound the watch, the spring is completely coiled; a steel chain, one end of which is hooked to the fusee and the other to the barrel, is at this moment almost completely wrapped around the spiral lines of the axis of the fusee. On unwinding itself, the spring turns the barrel, which communicates its movement to the fusee by the intermediary of the chain. This unwraps itself, little by little, from the fusee, and wraps around the barrel until there remain no more turns on the fusee. It is evident that if the tension of the spring continually diminishes, this action works in the contrary sense, always at a greater distance from the axis of the fusee. The motive work, product of the tension by the distance traversed, gives, designating the tension by  $P$ , the distance to the axis by  $r$  and the speed of rotation by  $w$ ,

$$P r w.$$

This work should be constant if the speed of the wheel fixed on the axis of the fusee is constant, that is to say, if there is a uniform angular speed, and the fusee is grooved in such a manner that the product  $P r$  remains constant. The variations of  $P$  must then be the reverse of those of  $r$ . An exception, however, must be made to the preceding, if one takes into account the friction of the pivots in the plates; this friction, in fact, diminishes constantly as



the pressure diminishes. We will, however, neglect this factor, in order not to complicate the following theory.

**114.** To determine practically whether or not the variation of the force of a spring is exactly counterbalanced by the form of the fusee, one uses a lever and a weight, as we have seen before (81); one fixes the lever on the square of the arbor of the fusee; the form of this piece will be exact if the weight carried by the lever makes equilibrium with the force of the spring at the same distance from the axis for each point of the successive rotations of the fusee.

**115. Calculation of the Variable Radius of the Fusee's Helix.** Let  $R$ , be the interior radius of the barrel, half the thickness of the chain being included therein;

$r$ , the variable radius of the fusee;

$r_0$ , its initial radius (in  $r$  and  $r_0$  is also included half the thickness of the chain);

$\theta$ , the maximum angle which the spring is wound, starting from the position where the elastic effect is null, and corresponding to the instant when the chain acts at the extremity of the radius  $r_0$ ;

$\alpha$ , the angle which the barrel has turned, starting from the position  $\theta$ ;

$\beta$ , the angle which the fusee has turned, starting from the instant when the chain acts at the extremity of the radius  $r_0$ .

The moment of the force of the spring can be expressed by

$$F = \frac{\frac{1}{2} E e^3 h}{L} (\theta - \alpha).$$

Placing

$$\frac{\frac{1}{2} E e^3 h}{L} = M$$

we will have

$$F = M (\theta - \alpha).$$

The force  $F'$  acting at the exterior of the barrel should be

$$F' = \frac{M}{R} (\theta - \alpha),$$

and the moment  $F_1$  with relation to the axis of the fusee is

$$F_1 = \frac{M r}{R} (\theta - \alpha).$$

The values of  $r$  and of  $\alpha$  should vary in such a manner that, in order that  $F_1$  may be constant, we should have  $\alpha$  equal to zero for  $r$  equal to  $r_0$ ; we will then have



$$\frac{M r_0}{R} = \frac{M r}{R} (\theta - \alpha),$$

whence

$$(1) \quad r = \frac{r_0 \theta}{\theta - \alpha}.$$

When the chain wraps up an infinitely small quantity,  $R d\alpha$ , on the barrel, it unwraps the same length,  $r d\beta$ , from the fusee. One has then

$$R d\alpha = r d\beta,$$

but, because of the equation (1),

$$d\beta = \frac{R}{r_0 \theta} (\theta - \alpha) d\alpha.$$

On integrating, it becomes

$$\beta = \frac{R}{r_0 \theta} \int (\theta - \alpha) d\alpha = \frac{R}{r_0 \theta} \left( \int \theta d\alpha - \int \alpha d\alpha \right).$$

These integrals should be taken between the limits  $\alpha = 0$  and  $\alpha = \alpha'$ , one will have

$$\int \theta d\alpha = \theta \alpha \text{ and } \int \alpha d\alpha = \frac{1}{2} \alpha^2;$$

consequently,

$$\beta = \frac{R}{r_0 \theta} (\theta \alpha - \frac{1}{2} \alpha^2).$$

Drawing from this equation the value of  $\alpha$  one will have first

$$-\frac{1}{2} \alpha^2 + \theta \alpha = \frac{r_0 \theta}{R} \beta;$$

changing the signs, adding  $\theta^2$  to each member and multiplying by 2, it becomes

$$\alpha^2 - 2\theta \alpha + \theta^2 = -\frac{2 r_0 \theta}{R} \beta + \theta^2,$$

and

$$\alpha - \theta = \pm \sqrt{\frac{2 r_0 \theta}{R} \beta + \theta^2};$$

consequently,

$$\alpha = \theta \pm \theta \sqrt{1 - \frac{2 r_0}{R \theta} \beta}.$$

Replacing now in equation (1)  $\alpha$  by this value, we will obtain

$$r = \frac{r_0 \theta}{\theta - \theta \pm \theta \sqrt{1 - \frac{2 r_0}{R \theta} \beta}},$$

or

$$r = \frac{r_0}{\sqrt{1 - \frac{2 r_0}{R \theta} \beta}}.$$



Placing  $\theta = 2 \pi n$  and  $\beta = 2 \pi n'$  we will have, finally,

$$(2) \quad r = \frac{r_0}{\sqrt{1 - \frac{2 r_0}{R} \frac{n'}{n}}}.$$

**116. Numerical Calculation of the Preceding Equation.** Let  $R = 8$  mm.,  $r_0 = 5$  mm.,  $\theta = 12 \times 2 \pi$  and let us calculate first the value of the radius  $r$  for an angle  $\beta = 2 \pi$ ; we will write, on replacing values,

$$r^1 = \frac{5}{\sqrt{1 - \frac{2 \times 5}{8 \times 12}}} = \frac{5}{\sqrt{1 - \frac{10}{96}}},$$

the calculation gives :

Log : 86 = 1.9344985	Log : 5 = 0.6989700
— log : 96 = 1.9822712	— log : $\sqrt{\frac{86}{96}}$ = 0.9761136
1.9522273 — 2	Log : $r^1$ = 0.7228564
Log : $\sqrt{\frac{86}{96}}$ = 0.9761136 — 1	and $r^1$ = 5.2827 mm.

Successive calculations will give us in an analogous manner the following results, which we group in a table :

For $\beta = 2 \pi$ ,	$r^1 = 5.2827.$
“ $\beta = 4 \pi$ ,	$r'' = 5.6195.$
“ $\beta = 6 \pi$ ,	$r''' = 6.0302.$
“ $\beta = 8 \pi$ ,	$r'''' = 6.5491.$
“ $\beta = 10 \pi$ ,	$r''''' = 7.2231, \text{ etc.}$

**117. Other Calculations.** It more often happens, in practice, that one is given the greatest radius of the fusee, and that the question is to determine the variable radius, starting from this value. This problem, the inverse of the preceding, is solved in an analogous manner. Preserving the same notations as in the preceding case, let  $r_0$  in this case be the greatest radius of the fusee and  $\theta$  the angle which the spring is set up at the instant when the chain acts at the extremity of the radius  $r_0$  of the fusee. We have the moment of the force of the spring :

$$F_0 = M \theta,$$

and in the initial position, when the barrel has turned an angle  $\alpha$ ,

$$F = M (\theta + \alpha).$$



The force  $F'$  acting at the exterior of the barrel will be for the two cases :

$$F'_0 = \frac{M}{R} \theta \text{ and } F' = \frac{M}{R} (\theta + \alpha),$$

and the moment of these forces with relation to the axis of the fusee will be :

$$F''_0 = \frac{M r_0}{R} \theta \text{ and } F'' = \frac{M r}{R} (\theta + \alpha).$$

Making these two values equal, one has

$$\frac{M r_0}{R} \theta = \frac{M r}{R} (\theta + \alpha),$$

or

$$r_0 \theta = r (\theta + \alpha),$$

from whence one extracts

$$(1) \quad r = \frac{r_0 \theta}{\theta + \alpha}.$$

As in the preceding case, we place

$$r d\beta = R d\alpha,$$

from whence

$$d\beta = \frac{R}{r} d\alpha.$$

Replacing  $r$  by its value (1), one obtains

$$d\beta = \frac{R}{r_0 \theta} (\theta + \alpha) d\alpha,$$

and on integrating,

$$\beta = \frac{R}{r_0 \theta} \left( \int \theta d\alpha + \int \alpha d\alpha \right),$$

from whence

$$\beta = \frac{R}{r_0 \theta} \left( \theta \alpha + \frac{1}{2} \alpha^2 \right).$$

Transformations analogous to the preceding case will give us successively :

$$\frac{1}{2} \alpha^2 + \theta \alpha = \frac{r_0 \theta}{R} \beta,$$

$$\alpha^2 + 2\theta \alpha + \theta^2 = \frac{r_0 \theta}{R} \beta + \theta^2,$$

$$\alpha + \theta = \sqrt{2 \frac{r_0 \theta}{R} \beta + \theta^2},$$

$$\alpha = -\theta \pm \sqrt{2 \frac{r_0 \theta}{R} \beta + \theta^2},$$

$$\alpha = -\theta \pm \theta \sqrt{\frac{2 r_0}{R \theta} \beta + 1}.$$



The value of  $\alpha$ , extracted from the equation (1), is equal to

$$\alpha = \frac{r_0}{r} \theta - \theta,$$

consequently,

$$\frac{r_0}{r} \theta - \theta = -\theta \pm \theta \sqrt{\frac{2 r_0}{R \theta} \beta + 1},$$

and

$$\frac{r_0}{r} \theta = \pm \theta \sqrt{\frac{2 r_0 \beta}{R \theta} + 1},$$

from whence

$$r = \frac{r_0}{\sqrt{\frac{2 r_0 \beta}{R \theta} + 1}};$$

or still further, by substituting  $\beta = 2 \pi n'$  and  $\theta = 2 \pi n$ ,

$$(2) \quad r = \frac{r_0}{\sqrt{\frac{2 r_0}{R} \frac{n'}{n} + 1}}.$$

**118. Numerical Calculation of the Preceding Equation.** As an example of the application of the preceding calculation, let us determine the dimensions of a marine chronometer's fusee and let the following be the data :

Exterior radius of the barrel including half the thickness of the chain, . . . . .  $R = 21.7$  mm.

Maximum radius of the fusee, . . . . .  $r_0 = 18.3$  mm.

Development of the spring, . . . . .  $n = 3.4$  turns.

Let us admit, that when the spring is set up one turn, the chain acts on an angle  $\beta = 0$ , in this case then

$$n' = 0.$$

When the fusee has made one turn, we then will have  $n' = 1$ , and on replacing the letters by their values in the formula (2), we will have

$$r = \frac{18.3}{\sqrt{\frac{2 \times 18.3 \times 1}{21.7 \times 3.4} + 1}}.$$

The calculation gives

$\begin{array}{r} \text{Log : } (2 \times 18.3) = \log : 36.6 = 1.5634811 \\ - \log : (21.7 \times 3.4) = \phantom{\log : 36.6} = 1.8679386 \\ \hline 0.6955425 - 1 \end{array}$	$\updownarrow$	$\begin{array}{r} \text{Log : } 21.7 = 1.3364597. \\ + \log : 3.4 = 0.5314789. \\ \hline 1.8679386. \end{array}$
Corresponding number = 0.4961		



$$\log : \sqrt{0.4961 + 1} = \frac{\log : 1.4961}{2}$$

$$\begin{array}{r} \log : 1.4961 = 0.1749606 \\ \log : \sqrt{1.4961} = 0.0874803 \end{array} \quad \begin{array}{r} \uparrow \\ \text{Log : } 18.3 = 1.2624511 \\ \text{---} \\ \phantom{\text{Log : }} = 0.0874803 \\ \hline \phantom{\text{Log : }} = 1.1749708 \\ \downarrow \\ \text{Number} = 14.961 \end{array}$$

We will then have the radius of the fusee for a number of turns  $n' = 1$  :

$$r_1 = 14.961 \text{ mm.}$$

Replacing, successively, in the preceding formula  $n'$  by 2, 3, 4, etc., one will arrive at the following results :

For $n' = 0,$	$r_0 = 18.3$
“ $n' = 1,$	$r_1 = 14.961$
“ $n' = 2,$	$r_2 = 12.965$
“ $n' = 3,$	$r_3 = 11.601$
“ $n' = 4,$	$r_4 = 10.593$
“ $n' = 5,$	$r_5 = 9.809$
“ $n' = 6,$	$r_6 = 9.177$
“ $n' = 7,$	$r_7 = 8.653$
“ $n' = 8,$	$r_8 = 8.21$

**119. Uniformity of the Spring's Force in Fusee Watches.** In order to obtain perfect uniformity of the spring's force in fusee watches, it is not sufficient alone to construct the fusee in a manner conformed to the data of the preceding calculations. There are other factors which must be taken into account, and about which we will give some explanations.

In order to verify the uniformity of the force of the spring with relation to the fusee, or, to speak in shop parlance, in order to *equalize* the fusee, one places the fusee and the barrel between the two plates of the watch, puts the chain in place, sets up the spring, and fastens on the arbor of the fusee the lever that we have mentioned (114).

Holding the movement of the watch in the hand, one then turns the lever a quarter of a turn and establishes equilibrium by means of weights ; then one turns the lever 1, 2, 3, etc., turns, taking care to notice if at each revolution the equilibrium is maintained.

But practice teaches that if, in this operation, one finds an *increase* of force, one approaches perfect equality by further *setting up* the mainspring ; if, on the contrary, the instrument shows a





**THIS PAGE IS LOCKED TO FREE MEMBERS**

Purchase full membership to immediately unlock this page

# DELVE INTO FANTASY, MAGIC, MYTHOLOGY & FOLKLORE

Forgotten Books'  
Full Membership gives  
access to 797,885 ancient  
and modern, fiction and  
non-fiction books.

**Continue**

\*Fair usage policy applies



**122.** In establishing the theory of the barrel spring, we have admitted these springs to be of the same thickness from one end to the other, that their coiled blades remain always concentric, that is to say, retain a spiral form during their development ; and, finally, that they are always free.

Practice shows that these conditions are not fulfilled by the spring inclosed in a barrel and that they cannot be so except for a free spring, such as the hairspring.

Let us examine rapidly, however, these three facts, commencing with the last expressed.

**123.** Complete liberty of the blades of the spring does not exist practically. Let us suppose, in effect, that one has turned the barrel arbor a small angle, a quarter turn, for example. In this position all the coils of the spring have not yet entered into play : there are found a certain number which remain pressed against each other, forming part of the barrel. One should then take the acting length of the spring  $L$ , equal to the length of the spring which has become free, and the number  $n$  equal to the number of turns that this free part contains at the instant considered, diminishing this value by the number of turns that this same length possesses when

it is placed freely on the table (97).

Thus (Fig. 22), if  $a$  is the end of the spring hooked to the hub, and  $b$  the point at which the free coils become separated from those which remain pressed against the drum of the barrel, the length  $L$  in the equation (97)

$$F = \frac{E h e^3 2 \pi n}{12 L}$$

is then only equal to the length of the part  $a b$  of

the spring. Furthermore, the number  $n$  will be equal to the number of coils which this part of the blade contains, diminished by the number of coils which this same length contains in the free position of the spring (Fig. 23). For example, we have (Fig. 22)

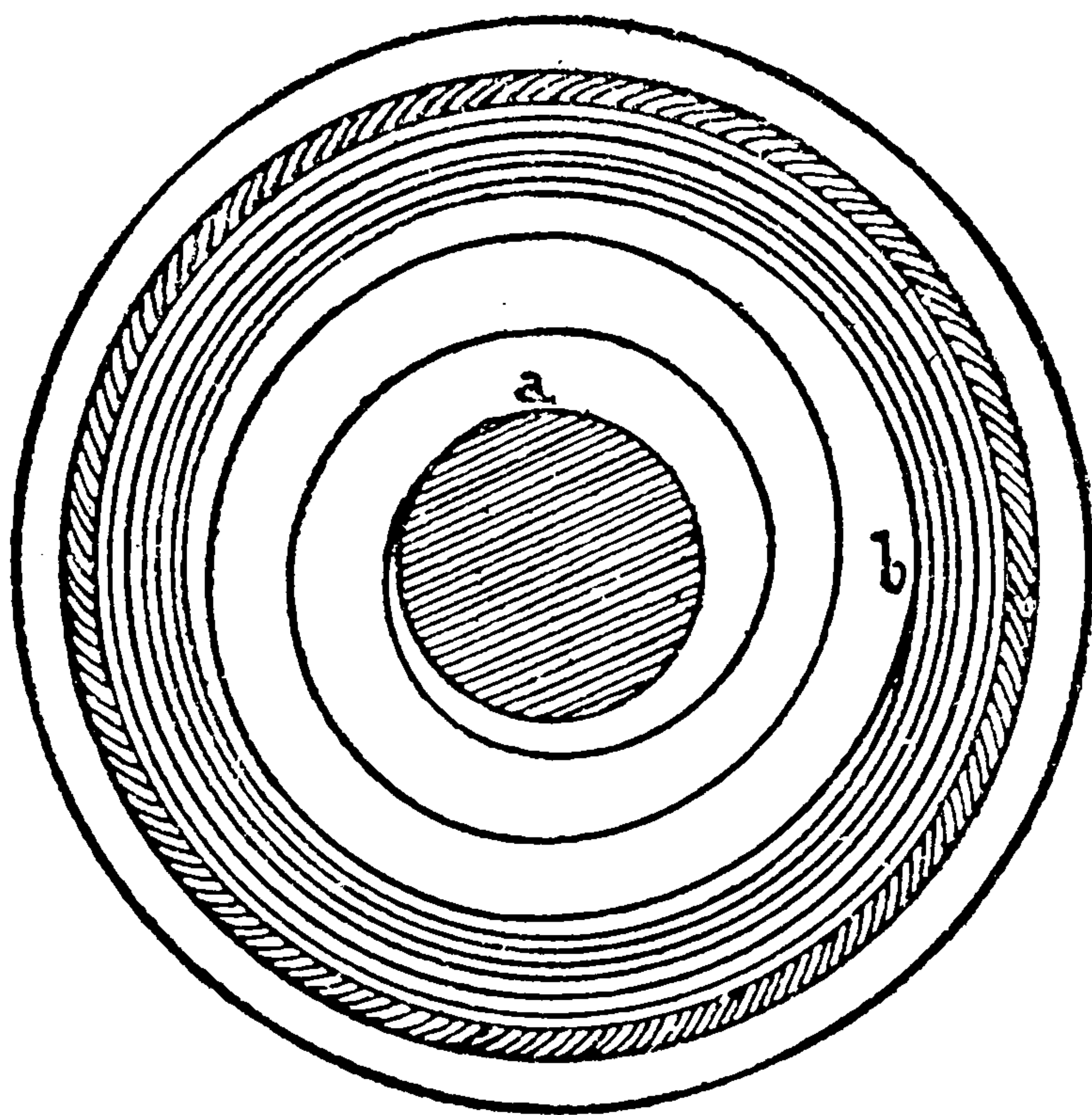

Fig. 22



$a b = 2\frac{3}{4}$  coils and (Fig. 23)  $a b = 2\frac{1}{2}$  coils ; consequently,  
 $n = 2\frac{3}{4} - 2\frac{1}{2} = \frac{1}{4}$ .

Let us note that in most watches in which the barrel makes three turns in 24 hours, one can readily admit that the whole blade

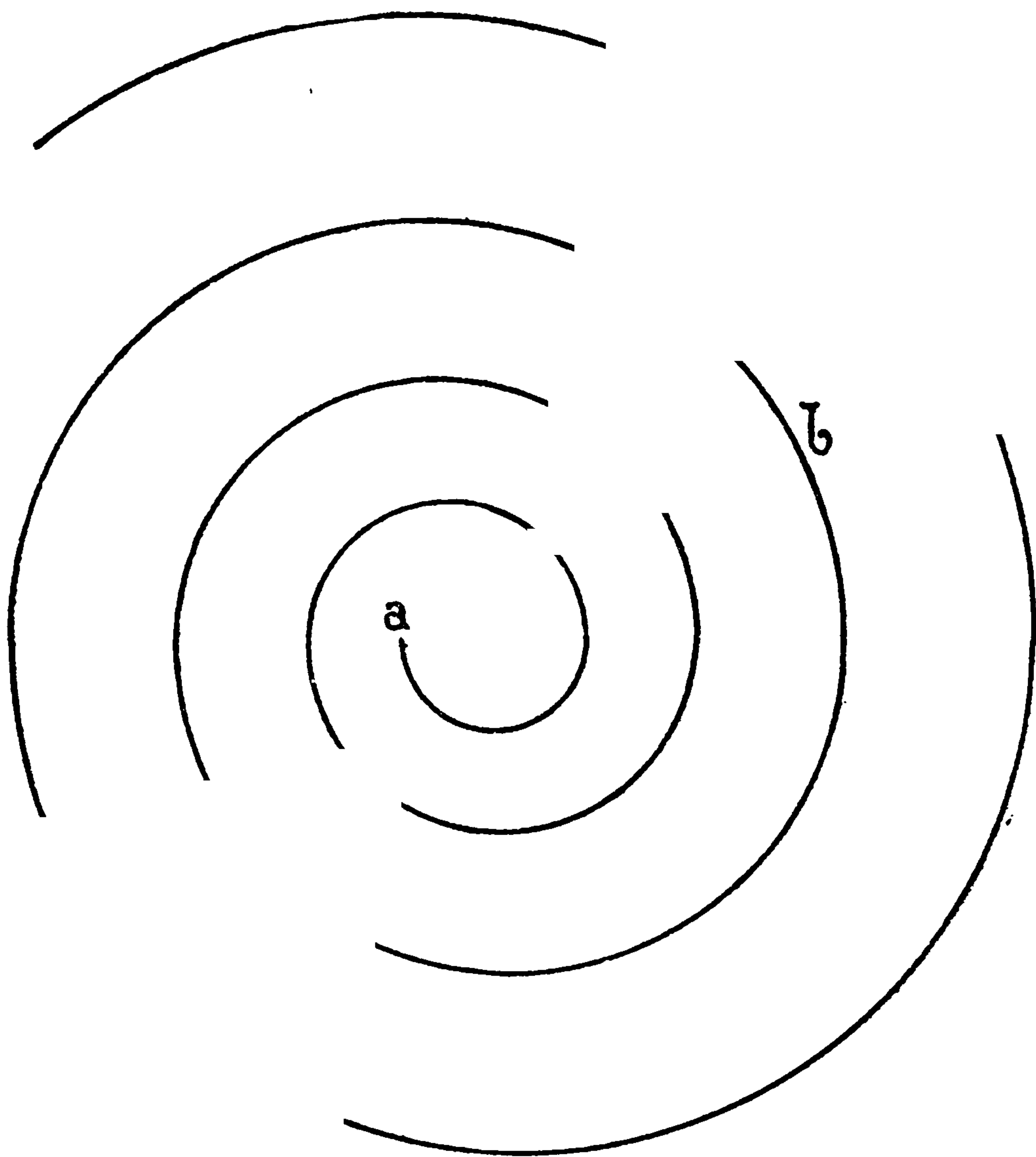

Fig. 23

becomes free, while the spring is developed these three turns, and one can employ, without great error, the above formula, without modifying anything therein.

**124.** Some have tried to use springs of varying thickness, that is, those whose blades increase or diminish in thickness from one end to the other.

Let us suppose in the first place that the thickness may constantly increase ; at the interior, the blade, being thinner, will bend more easily ; during the winding of the watch, the coils which detach themselves from those which remain pressed together, will perform this movement in a more gradual manner than if the



thickness were the same along the whole length. On continuing to wind the spring some of the coils will be wrapped around the hub and form part of it. Thus, the moment of the force of the spring could only be determined in this case by taking the length of its free part alone, and the value of  $n$  should also be determined according to this length. Since the thickness, moreover, is variable, it becomes difficult to determine by calculation the force of such a spring in a sufficiently exact manner.

Such springs are used to advantage in fusee watches, because they have a more concentric development and consequently produce less friction between the coils.

If, on account of the diminution of thickness at the interior, there results a greater difference between the moments of force of the beginning and the end, this difference could easily be corrected by the fusee.

**125.** Springs thicker at the interior than at the exterior are hardly to be recommended, for the interior part of the blade bending only with difficulty is hard to wind around the hub ; it has, moreover, the effect of detaching a greater length of blade from the part that remains pressed against the barrel, which produces considerable friction between the coils. These springs have, moreover, a great tendency to break.

**126.** The principal defect of the development of the spring in the interior of the barrel is that which arises from the eccentric coiling or uncoiling of the blades ; these push themselves to one side, both at the interior and at the exterior of the spring. This is, also, an analogous fact to that which shows itself in a flat spiral without return curve. When the interior fault comes into contact with the exterior fault, the spring makes a sudden jump, producing a noise well known to watchmakers. The exterior fault can be remedied by fixing to the spring a flexible check of sufficient length, about a half turn ; this check should be made thin in the part which is fastened to the barrel, in order to permit it to follow freely the coiling up of the spring. A better remedy would be to have the last exterior half turn thicker and make it gradually thinner to suit the conditions.

### **Stop-Work.**

**127.** We designate by this name a mechanism fastened to the barrel and whose object is to stop the winding before the spring is completely coiled around the hub. This same mechanism also



stops the running of the watch before the spring is completely pressed against the inner wall of the barrel; its effect then is to utilize only a part of the development of the spring, that during which the force is most equal. Thus the total development of the spring being, for example, six turns, if the unwinding is arrested by the stop-work after four turns and a half, the spring will still be stretched one turn and a half when the watch stops.

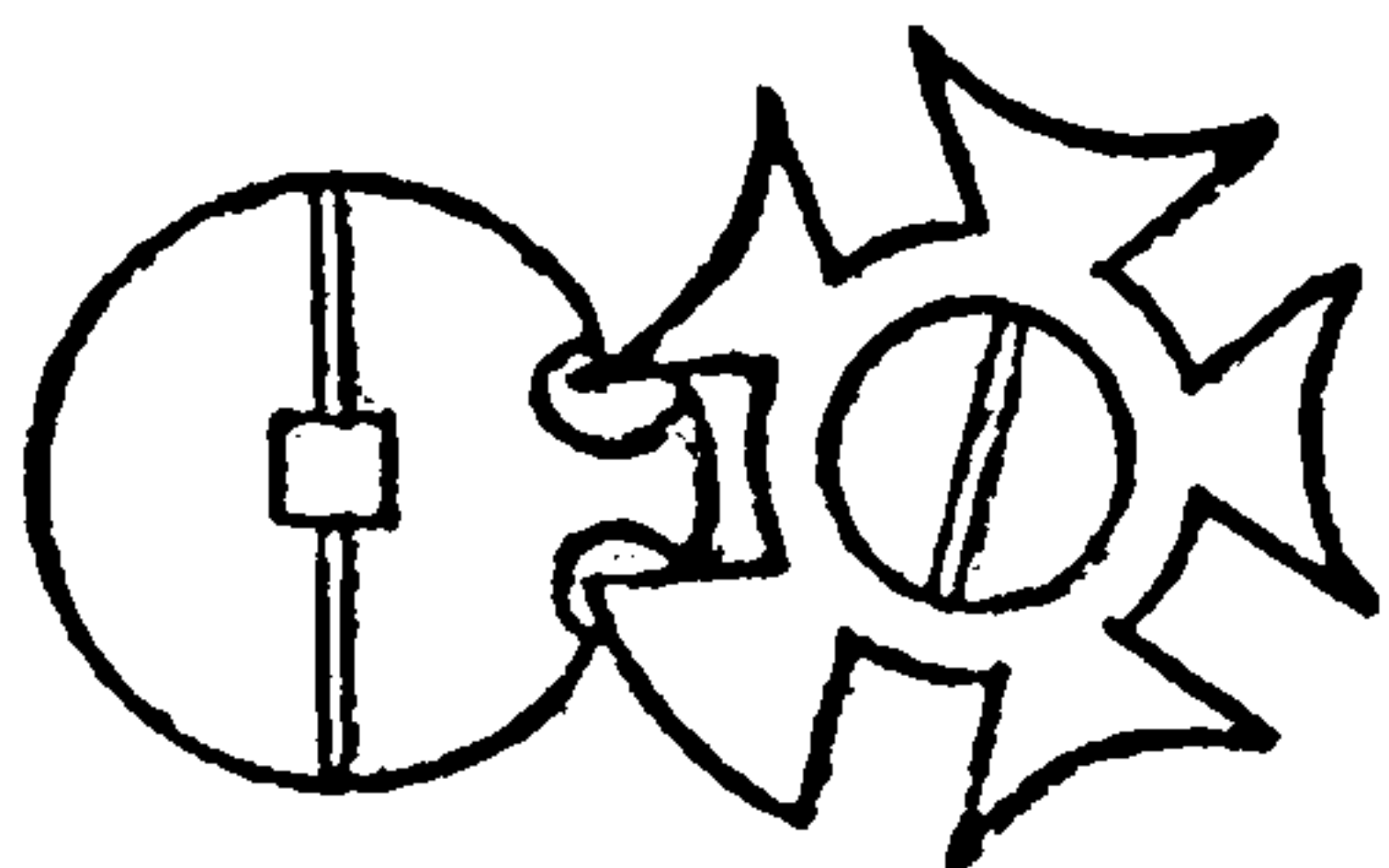

Fig. 24

In most watches, in fact, this mechanism allows the barrel to make four revolutions on its arbor, and if it makes one turn in eight hours, as is often the case, the watch should run for 32 hours.

The most modern stop-work is what is called the "maltese cross." It is composed of two pieces, the *finger* and the *wheel*.\* The latter being shaped like a maltese cross, gives it this name. The wheel is placed on the barrel, where it can turn freely, while the finger is placed on the arbor. The head of this piece gears in the notches of the cross, the rounded out teeth of which can successively slip around the circumference of the finger.

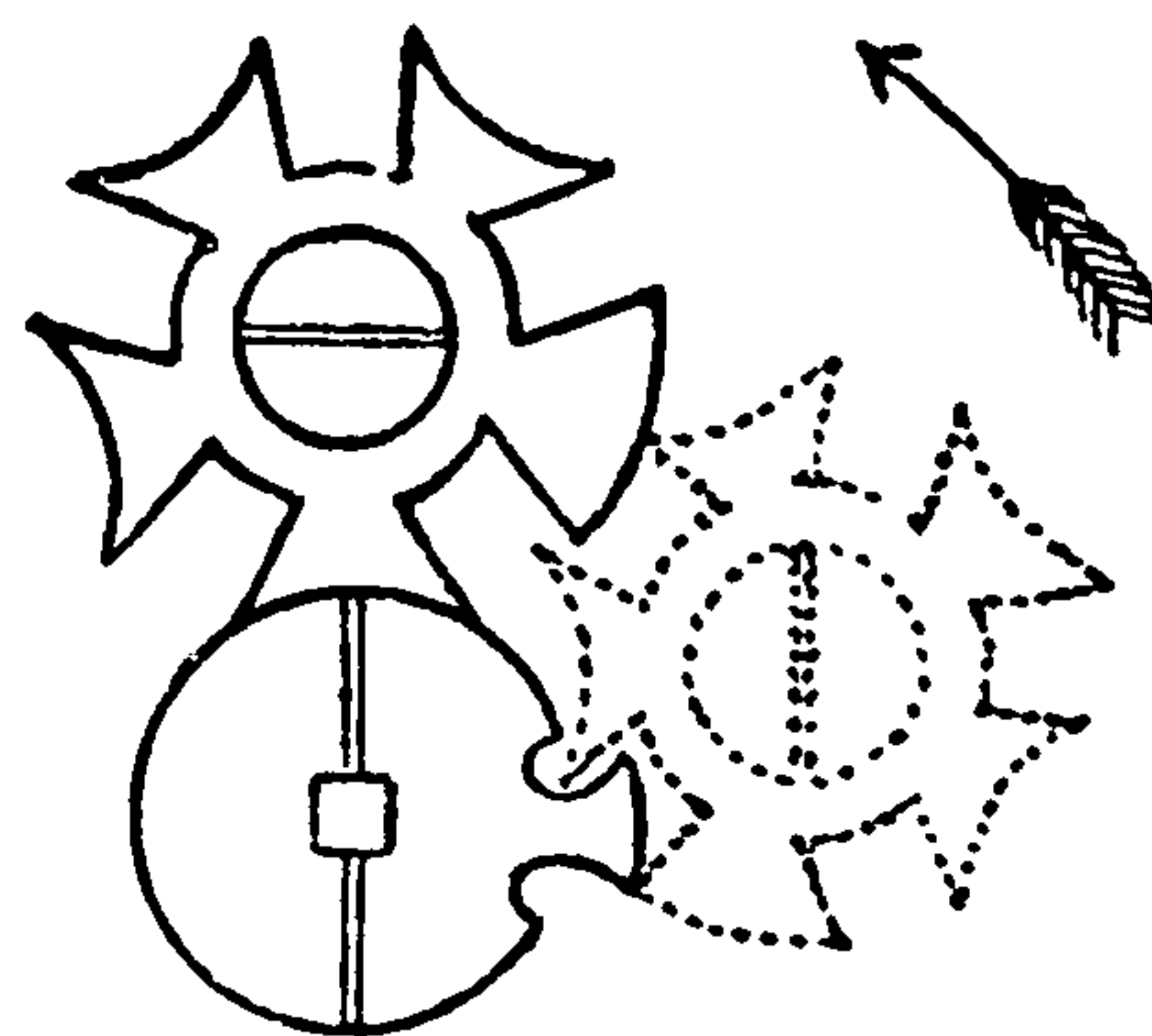

Fig. 25

On winding the watch, one turns the barrel arbor; the finger participates then in this movement and pushes, at each turn, a tooth of the wheel until the moment when the shoulder of the finger comes into contact with the full tooth of the wheel; the movement is then stopped, and the watch is wound (Fig. 24).

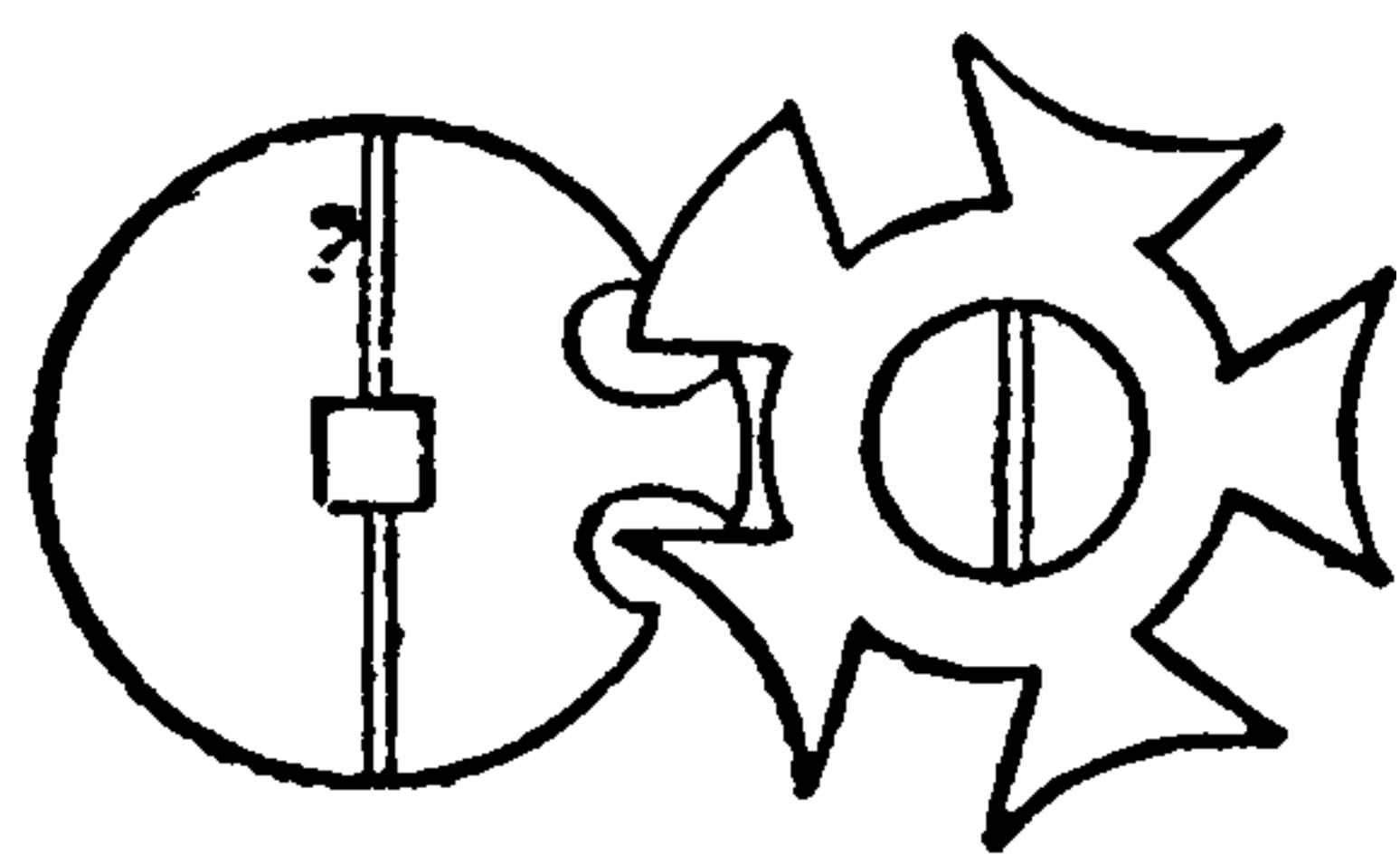

Fig. 26

During the running of the watch, the finger is stationary and the wheel, turning with the barrel, at each turn presents one of its openings in front of the end of the finger, which forces it to make a fraction of a revolution on its axis (Fig. 25). After the four revolutions of the barrel, the other shoulder of the finger comes again in contact with the full tooth of the wheel, and the watch is stopped (Fig. 26).

### 128. Geometrical Construction of the Maltese Cross Stop-Work.

In order to construct, graphically, this stop-work, we will suppose

\* These pieces are commonly known as the male and female.—TRANSLATOR.



that the distance  $O O'$  between the centers of the barrel and of the maltese cross wheel is known (Fig. 27). We divide this distance into five equal parts, and from the center  $O$ , with a radius equal to three of these divisions, one describes a circumference, which is repeated a second time from the point  $O'$  as center. From this last center we further describe a new circle passing through the center of the barrel, and we divide this last circumference into five

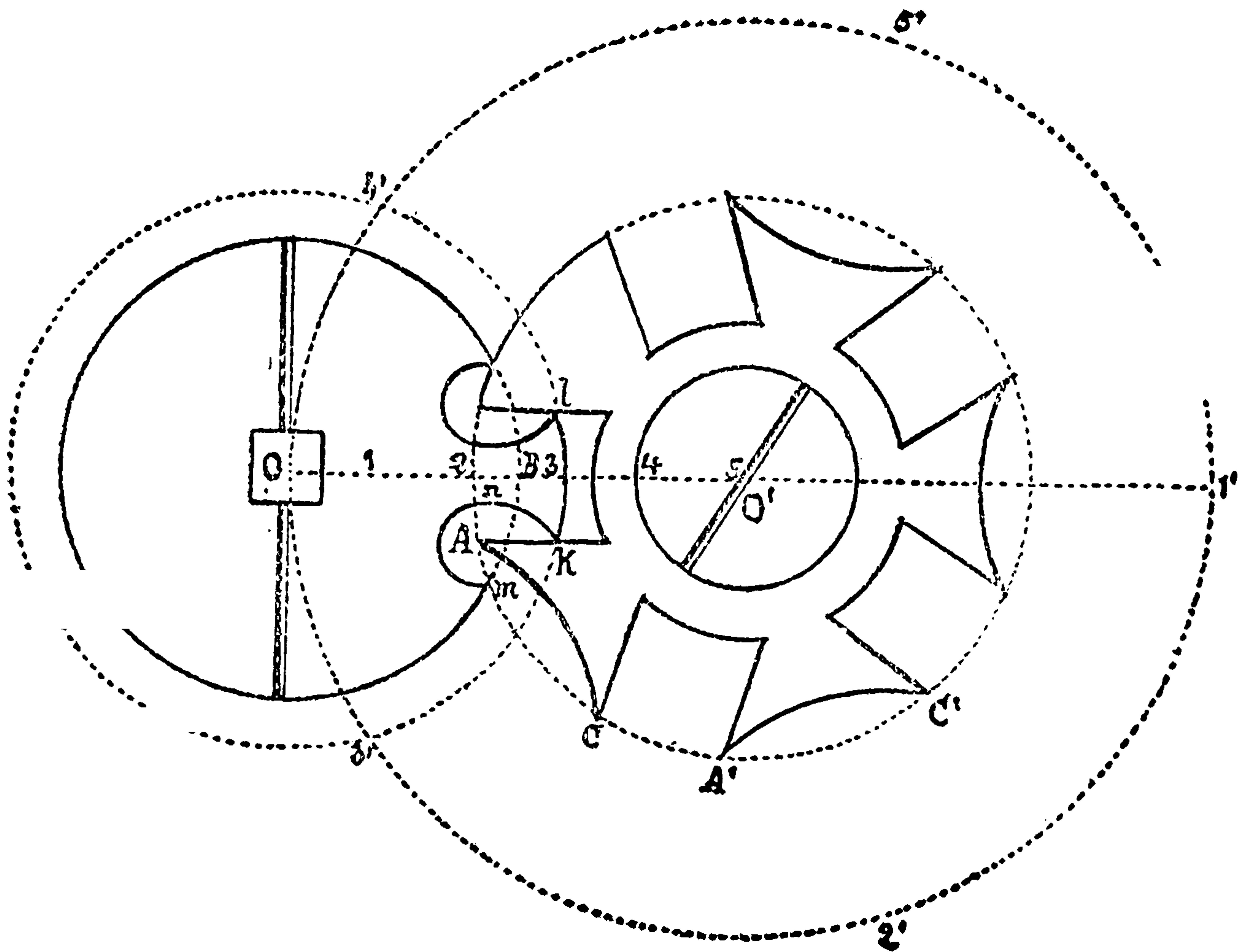

Fig. 27

equal parts. In order to get the end of the finger in one of the openings of the maltese cross, the division is commenced at the point  $1'$ ; for other cases we will commence to divide at the point  $O$  or any other intermediate point.

The circumference of the finger is described with a radius equal to half of the distance  $O O'$ ; from the points  $1'$ ,  $2'$ ,  $3'$  and  $5'$  we will trace with the same radius the arcs  $A C$ ,  $A' C'$ , etc., the arms of the cross. The intersections  $C A'$ , etc., will, consequently, determine the size of the openings, the straight sides of which are drawn parallel to each other and at equal distances from the center  $O'$ .



The essential conditions to be fulfilled in making the end of the finger are the solidity of the piece and the free action of the mechanism. We prefer to represent it by means of two arcs of circles : one  $m n$ , whose length equals a semi-circumference, and the other  $n k$ , whose center is found almost on the point of the shoulder of the finger.

Practically, the end of the finger  $k l$  should be slightly smaller than the corresponding opening of the other piece, that is to say, there should exist a certain play, to assure the free action of the mechanism ; this play will be easily obtained by taking off the sharp corners  $k$  and  $l$  of the finger.

It is also to be recommended, in practice, to make the full tooth of the maltese cross with a radius  $O' D$  longer than the radius  $O' C$  of the cut-out teeth, in order to cause the stoppage a little before the line of centers. It is, moreover, necessary to slightly round off the corners  $A, C, A', C'$ , etc., of the teeth of the wheel.



## CHAPTER III.

### Wheel-Work.

**129. Purposes of Wheel-Work.** The wheels of a watch and of a clock have a double duty to fulfill : first, to transmit the movement arising from the motive power, from the first mobile down to the escapement ; second, to reckon the number of oscillations accomplished by the balance wheel in a given time, indicating this time by means of hands on a spaced dial.

Since on the one hand the movement of the balance wheel is a rapid one and on the other the motive force should only be expended slowly, and, moreover, the wheels carrying the hands should make certain numbers of turns, according to given relations, one understands that the wheel-work should be arranged in such a manner as to multiply, progressively, the speed of the first mobile. This is why we make the wheels gear into pinions, and the numbers of teeth of these different mobiles should be exactly determined.

Let us further remark that in thus considerably increasing the speed, we diminish in the same proportion the force transmitted to the escape wheel.

#### Calculations of Trains.

**130. Calculations of the Number of Turns.** Let us determine, first, the relation which should exist between the number of turns made by the moving bodies of a gearing and their number of teeth. Knowing the number of teeth  $A$  in a wheel, and of leaves in the pinion  $a$ , in which it gears, we have then to find the number of rotations accomplished,  $n'$ , by the pinion while the wheel makes a number  $n$ .

Let us suppose a wheel  $A$  of 96 teeth gearing in a pinion  $a$  of 12 leaves : since each tooth of the wheel drives one leaf of the pinion, it is evident that, while the pinion makes one rotation, as many teeth of the wheel will have advanced as there are leaves in the pinion, and, consequently, the pinion will make as many turns as the number of times its leaves are contained in the teeth of the wheel ; one will have, then,

$$n' = \frac{A}{a} = \frac{96}{12} = 8.$$





**THIS PAGE IS LOCKED TO FREE MEMBERS**

Purchase full membership to immediately unlock this page

# HISTORY

Tens of thousands of important historical sources, many previously unobtainable, are now available for the first time with a Forgotten Books Full Membership.

Unlimited Access  
\$8.99/month

**Continue**

\*Fair usage policy applies





fourth pinion 10 leaves, one will find the number of turns that this last pinion should make while the center wheel makes 1, by replacing the letters of the formula (3) by their numerical values, then

$$n'' = 1 \times \frac{80 \times 75}{10 \times 10} = 60 \text{ turns.}$$

The fourth pinion, then, makes 60 rotations while the center wheel makes one. Since the axis of the center wheel carries the minute hand and the axis of the fourth wheel carries the second hand, the movement will be executed, properly, according to the accepted division of time.

If it were necessary to calculate the number of rotations of the fourth pinion, while the center wheel made 24, one would place in an analogous manner

$$n'' = 24 \times \frac{80 \times 75}{10 \times 10} = 1440 \text{ turns.}$$

**132.** One could determine, in like manner, for any number of wheels and pinions, the relation of the numbers of turns of the last pinion to those of the first wheel. This relation is always equal to the quotient obtained by dividing the product of the numbers of teeth in the wheels by the product of the number of leaves in the pinions. One can then establish, in a general manner

$$(5) \quad \frac{n'''}{n} = \frac{A B C D E \dots\dots\dots}{a b c d e \dots\dots\dots}$$

Suppose, for example, we wish to determine the number of revolutions accomplished by an escape pinion while the barrel makes 4, knowing that this barrel has 96 teeth, the center wheel also 96, the third wheel 90, the fourth wheel 80, and that all the pinions have 12 leaves, except that of the escape, which has 8. We would write the formula (5) under the form :

$$(6) \quad n'''' = n \frac{A B C D}{a b c d},$$

from whence, by replacing values,

$$n'''' = 4 \times \frac{96 \times 96 \times 90 \times 80}{12 \times 12 \times 12 \times 8} = 19200 \text{ turns.}$$

### **133. Calculation of the Number of Oscillations of the Balance.**

It is generally customary to indicate the number of oscillations which the balance wheel of a watch makes during one hour, that is, while the center wheel, which carries the minute hand on its axis, makes one turn.



134. We have already called attention to the fact that in most of the escapements the action of each tooth of the wheel corresponds to two oscillations of the balance (71). Knowing then the number of rotations which the escape wheel makes during one hour, one will easily calculate the number of oscillations which the balance executes during this same time, by multiplying the number of turns of the escape wheel by twice the number of its teeth, an operation which can be represented, designating the number of teeth of this last wheel by  $E$  and the number of oscillations by  $N$ , by the formula

$$(7) \quad N = 2 E n'''.$$

If an escape wheel with 15 teeth makes, for example, 600 turns while the center wheel makes 1, we will obtain the number of oscillations made by the balance by

$$N = 2 \times 15 \times 600 = 18000 \text{ oscillations.}$$

135. If we designate by

$B$ ,	the number	of teeth	of the	center	wheel,	
$C$ ,	“	“	“	“	“	third “
$D$ ,	“	“	“	“	“	fourth “
$b$ ,	“	“	“	leaves	“	“ third pinion,
$c$ ,	“	“	“	“	“	“ fourth “
$d$ ,	“	“	“	“	“	“ escape “

we should have, according to the formula (5)

$$n''' = n \frac{B C D}{b c d};$$

but since  $n = 1$

$$n''' = \frac{B C D}{b c d}.$$

Replacing  $n'''$  by this last value in the equation (7), we will obtain the general formula

$$(8) \quad N = \frac{B C D 2 E}{b c d},$$

a formula which enables us to calculate the number of oscillations made by a balance wheel during one hour, knowing the numbers of teeth of the different mobiles.

Suppose, for a numerical example, we desire to calculate the number of oscillations of a balance, knowing that

$$\begin{array}{llll} B = 64 & C = 60 & D = 60 & E = 15 \\ b = 8 & c = 8 & d = 6. & \end{array}$$



The application of the formula (8) will give

$$N = \frac{64 \times 60 \times 60 \times 2 \times 15}{8 \times 8 \times 6} = 18000 \text{ oscillations.}$$

**136. Calculations of the Numbers of Teeth.** Suppose now we wish to calculate the numbers of teeth in the wheels and of leaves in the pinions, the numbers of turns or of oscillations being known. This question, the reverse of the preceding one, can have several solutions ; in short, if one takes the equation

$$\frac{n''''}{n} = \frac{A B C D}{a b c d},$$

in which the relation  $\frac{n''''}{n}$  alone may be known, and in which the unknown quantities may be  $A, B, C, D$  and  $a, b, c, d$ , one sees immediately that an unlimited number of values could satisfy this relation ; the equation is, in fact, indeterminate and affords as many unknown quantities as there are wheels and pinions.

In order to determine them, one chooses arbitrarily the value of some of these unknown quantities, and, in order that the result will contain no fractions, one chooses for numbers of leaves in the pinions those employed in practical use.

These numbers are, generally, 6, 7 and 8 for the escape pinions, 8, 10 and 12 for the pinions of the third and fourth wheels, 10, 12 and 14 for the pinions of the center wheels.

The values  $a, b, c, d$  becoming, thus, known quantities, could be transposed to the first member of the equation, which will be written under the form

$$\frac{n''''}{n} a b c d = A B C D.$$

In order to solve this equation, it will suffice, then, to resolve all the known numbers of the first member into their prime factors and to form these factors into as many groups as there are unknown quantities to be determined.

Let us take a numerical example, and suppose that the relation in the above equation be

$$\frac{n''''}{n} = 4800.$$

We will then have

$$4800 = \frac{A B C D}{a b c d};$$

let us choose the following numbers of leaves for the pinions :  $a = 10, b = 10, c = 10$  and  $d = 7$ , we will place

$$4800 \times 10 \times 10 \times 10 \times 7 = A B C D.$$



Resolving 4800 with its prime factors, we obtain

4800	
2400	2
1200	2
600	2
300	2
150	2
75	2
25	3
5	5
1	5

$$4800 = 2^6 \times 3 \times 5^2$$

$$10 = 2 \times 5$$

and 7 is already a prime number.

One will have then the total product :

$$2^9 \times 3 \times 5^5 \times 7 = 4800 \times 10 \times 10 \times 10 \times 7 = A B C D,$$

with the factors of which we can form the following groups :

$A = 2^4 \times 5$	$= 80$	or	$A = 2^2 \times 5^2$	$= 100$
$B = 2^4 \times 5$	$= 80$	“	$B = 2^2 \times 3 \times 7$	$= 84$
$C = 3 \times 5^2$	$= 75$	“	$C = 2^4 \times 5$	$= 80$
$D = 2 \times 5 \times 7$	$= 70$	“	$D = 2 \times 5^2$	$= 50$

etc., etc.

By employing other numbers of leaves for the pinions, one can multiply the solutions to infinity. As proof, we could have

$$4800 = \frac{80 \times 80 \times 75 \times 70}{10 \times 10 \times 10 \times 7} = \frac{100 \times 84 \times 80 \times 50}{10 \times 10 \times 10 \times 7}.$$

**137.** When the relation  $\frac{n'''}{n}$  is fractional, one factors the numerator and denominator separately, then cancels the common factors. In a case where this elimination could not be effected, the problem would become impossible with the number of leaves chosen, and it would be necessary to replace them by others.

For example, let the formula be

$$\frac{n''}{n} = \frac{360}{7}.$$

It is impossible to solve this case with two pinions of 10 leaves, for in

$$\frac{360 \times 10 \times 10}{7} = \frac{2^5 \times 3^2 \times 5^3}{7}$$

there exists no factor 7 in the numerator which could serve to eliminate that of the denominator. On the other hand, if one chooses the two numbers 14 and 10, one will have

$$\frac{360 \times 14 \times 10}{7} = \frac{2^5 \times 3^2 \times 5^2 \times 7}{7}$$

and will be able to cancel the factor 7. One forms, then, two groups with the figures which remain, and obtains, for example,

$$A = 2^4 \times 5 = 80$$

$$B = 2 \times 3^2 \times 5 = 90.$$



As proof, one will have correctly,

$$\frac{80 \times 90}{10 \times 14} = \frac{360}{7}.$$

138. Let the question be, now, to determine the numbers of teeth in the wheels of a watch, whose balance should make 16200 oscillations per hour. The formula (8) gives

$$16200 = \frac{B C D 2 E}{b c d};$$

let us choose for the pinions the following numbers of leaves :

$$b = 12, c = 10, d = 8;$$

since the number of teeth in the escape wheel varies only within very narrow limits, we can further replace the letter *E* by the figure 15, for example. This number is, in fact, that which is very generally used for watches of medium size. One will then have :

$$16200 = \frac{B C D \times 2 \times 15}{12 \times 10 \times 8}.$$

or, on transposing the known terms,

$$\frac{16200 \times 12 \times 10 \times 8}{2 \times 15} = B C D.$$

Further simplification gives

$$16200 \times 2 \times 4 \times 4 = B C D.$$

Resolving into prime factors, one obtains

$$2^8 \times 3^4 \times 5^2 = B C D,$$

with which one can form the following groups :

$$\begin{aligned} B &= 2 \times 3^2 \times 5 = 90 \\ C &= 2^4 \times 5 = 80 \\ D &= 2^3 \times 3^2 = 72. \end{aligned}$$

The verification of the operation should give

$$16200 = \frac{90 \times 80 \times 72 \times 2 \times 15}{12 \times 10 \times 8}.$$

We will occupy ourselves, in the problems which follow, with the numbers of teeth to be given to the barrel and to the pinion of the center wheel.

139. The number of oscillations of the balance varied greatly in the earliest watches ; this figure was governed by no fixed rule and would vary between 17000 and 18000. As these watches had



no second hands, this number had only a relative importance within these limits.

In our modern timepieces, especially in watches above 12 lines (27 mm.), five oscillations per second, which would be 18000 per hour, are generally adopted.

In smaller pieces, this figure is increased to six oscillations per second, being 21600 per hour, with the object of diminishing the influence of jars in carrying, always very perceptible on the small balance with which these watches are supplied.

A great many of the English watches beat 16200 oscillations, being  $4\frac{1}{2}$  per second.

Marine chronometers beat four oscillations per second, or 14400 per hour.

**140.** The problems which follow are the applications of the preceding theories and will aid in the better understanding of these various questions. We especially insist on the constant use of the formulas, and urge the pupils to accustom themselves to solve these questions by applying to each case the equation which suits it. The algebraic way is a sure guide which leads always to a correct solution and to exact results. In the following exercises we give numerous examples of the reliability of calculation which results from the use of the simple formulas which we have just established.

#### Problems Relative to the Preceding Questions.

**141.** *A barrel of 80 teeth gears in a center pinion with 10 leaves; how many turns will this pinion make while the barrel makes 1?*

Solution : We have the formula (1) which gives

$$n' = n \frac{A}{a} = 1 \times \frac{80}{10} = 8.$$

The pinion executes 8 turns while the barrel makes 1 ; one revolution of the barrel has then, in this case, a duration of 8 hours.

**142.** *How many turns will this same pinion make while the barrel makes 4?*

Solution : The formula (1) further gives

$$n' = n \frac{A}{a} = 4 \times \frac{80}{10} = 32.$$

While the barrel makes 4 turns the center pinion makes 32. Since the stop-works are placed in such a manner that the barrel



can execute exactly four rotations on its axis (127), the watch will, therefore, run for 32 hours.

**143.** *A center wheel with 64 teeth gears in a third wheel pinion with 8 leaves; the third wheel with 60 teeth gears in a pinion with 8 leaves also. How many turns will this last pinion make during one turn of the center wheel?*

Solution : The formula (3)

$$n'' = n \frac{A B}{a b}$$

gives us, after substituting,

$$n'' = 1 \times \frac{64 \times 60}{8 \times 8} = 60.$$

The fourth pinion will make 60 rotations during one revolution of the center wheel, therefore, during one hour.

**144.** *What is the number of rotations which an escape pinion with 7 leaves will make during 12 hours, knowing that the center wheel with 80 teeth gears in a pinion of the third wheel with 10 leaves, the wheel of which with 75 teeth gears in the fourth pinion with 10 leaves; the fourth wheel having 70 teeth?*

Solution : We will use the general formula for a train of three gearings :

$$n''' = n \frac{A B C}{a b c},$$

from whence, after substituting values,

$$n''' = 12 \times \frac{80 \times 75 \times 70}{10 \times 10 \times 7} = 7200 \text{ turns.}$$

**145.** *What is the number of turns executed by an escape pinion during 3 turns of the barrel, the wheel-work having the following teeth-ranges :*

Barrel . . . .	96 teeth,	Center pinion	12 leaves,
Center wheel	90 "	Third	" 12 "
Third	" 80 "	Fourth	" 10 "
Fourth	" 72 "	Escape	" 8 "

Solution : Using the formula, we have

$$n'''' = n \frac{A B C D}{a b c d},$$

or

$$n'''' = 3 \times \frac{96 \times 90 \times 80 \times 72}{12 \times 12 \times 10 \times 8} = 12960 \text{ turns.}$$

**146.** *Suppose we wish to calculate the number of oscillations which a balance makes during one hour; the center wheel having 64 teeth, the third wheel 60, the fourth wheel 56, the escape*





**THIS PAGE IS LOCKED TO FREE MEMBERS**

Purchase full membership to immediately unlock this page

# DELVE INTO FANTASY, MAGIC, MYTHOLOGY & FOLKLORE

Forgotten Books'  
Full Membership gives  
access to 797,885 ancient  
and modern, fiction and  
non-fiction books.

**Continue**

\*Fair usage policy applies



It is then preferable to choose, always, the number of leaves in the pinion, and to determine from these the numbers of teeth in the wheels.

**148.** *To determine the number of teeth in a third wheel and the number of leaves in a fourth pinion combined in such a manner that the pinion makes 15 rotations while the wheel makes 2.*

Solution : One will use (2)

$$\frac{n'}{n} = \frac{A}{a}.$$

and, after substituting

$$\frac{15}{2} = \frac{A}{a}.$$

Since 15 and 2 are prime to each other and it is, therefore, impossible to simplify their relation, it is necessary, in order to avoid fractional numbers, that  $A$  be a multiple of 15 and  $a$  a multiple of 2 ; thus one could have

$$\frac{15}{2} = \frac{45}{6} = \frac{75}{10} = \frac{90}{12}, \text{ etc.}$$

The numbers 45, 75, 90 will, therefore, be suitable for the wheel  $A$ , and 6, 10, 12 for the pinion  $a$ .

**149.** *We wish to know the number of teeth in a barrel and the number of leaves in the center pinion in which it gears, so that the watch may run 8 days with 4 turns of the barrel.*

Solution : From the equation (2) we find the value

$$A = \frac{n'}{n} a,$$

in which  $n' = 8 \times 24 = 192$  and  $n = 4$  ; then,

$$A = \frac{192}{4} a = 48 a.$$

Replacing  $a$  by the numbers 6, 7, 8 and 10, successively, one finds that

$$\begin{aligned} A &= 48 \times 6 = 288 \\ A &= 48 \times 7 = 336 \\ A &= 48 \times 8 = 384 \\ A &= 48 \times 10 = 480. \end{aligned}$$

These solutions have the disadvantage of giving too great a number of teeth to the barrel, for even on choosing for  $a$ , a pinion of 6 leaves, one obtains, still, a barrel with 288 teeth.

In order to avoid this inconvenience, one sometimes has recourse to an intermediate pinion between the barrel and the



center wheel ; the barrel would gear in this pinion and the wheel mounted on the axis of this pinion should gear in that of the center wheel. The difficulty is thus changed and becomes that of finding a place in the watch in which to put another mobile and of increasing the motive power a very appreciable quantity.

In order to solve the problem thus arising, we will make use of formula (4)

$$\frac{n''}{n} = \frac{A B}{a b}$$

and we will have

$$\frac{192}{4} = \frac{A B}{a b} = 48.$$

Choosing for  $a$  12 leaves and for  $b$  10, one has

$$A B = 48 \times 12 \times 10.$$

Resolving the two members of the equation into their prime factors, one will obtain

$$2^7 \times 3^2 \times 5 = A B,$$

with which one could form the two groups

$$\begin{aligned} A &= 2^3 \times 3^2 = 72 \\ B &= 2^4 \times 5 = 80, \end{aligned}$$

or else

$$\begin{aligned} A &= 2^5 \times 3 = 96 \\ B &= 2^2 \times 3 \times 5 = 60. \end{aligned}$$

As proof, one should find that

$$48 = \frac{72 \times 80}{12 \times 10} = \frac{96 \times 60}{12 \times 10}.$$

**150.** *Suppose we wish to determine the numbers of teeth and of leaves in the wheels and pinions forming the dial wheels. Description of this mechanism.*

The *dial wheels* are the mechanism whose object is to secure the movement of the hour hand. Since the center wheel makes one turn per hour, one fixes on the prolongation of its axis, under the dial, a second pinion, called the *cannon pinion*. This adjustment is made in such a manner that this cannon pinion participates in the movement of the center wheel during the ordinary running of the watch, although it is possible to give it a separate movement when one wishes to set the hands. Thus the center wheel, the cannon pinion and the minute hand have a common movement and make one turn per hour. The cannon pinion  $a$  gears in the *minute wheel*









**THIS PAGE IS LOCKED TO FREE MEMBERS**

Purchase full membership to immediately unlock this page

# HISTORY

Tens of thousands of important historical sources, many previously unobtainable, are now available for the first time with a Forgotten Books Full Membership.

Unlimited Access  
\$8.99/month

**Continue**

\*Fair usage policy applies





Take, for example,  $a = 12$  and  $b = 10$ , one would have

$$24 \times 12 \times 10 = A B$$

and

$$2^6 \times 3^2 \times 5 = A B,$$

from whence

$$A = 2^4 \times 3 = 48$$

$$B = 2^2 \times 3 \times 5 = 60.$$

Proof

$$\frac{48 \times 60}{12 \times 10} = 24.$$

**152.** If the same dial ought to show, by means of two pairs of hands of different color or shape, the division of time into 24 hours and the division into 12 hours (Fig. 30), it would be easy to use

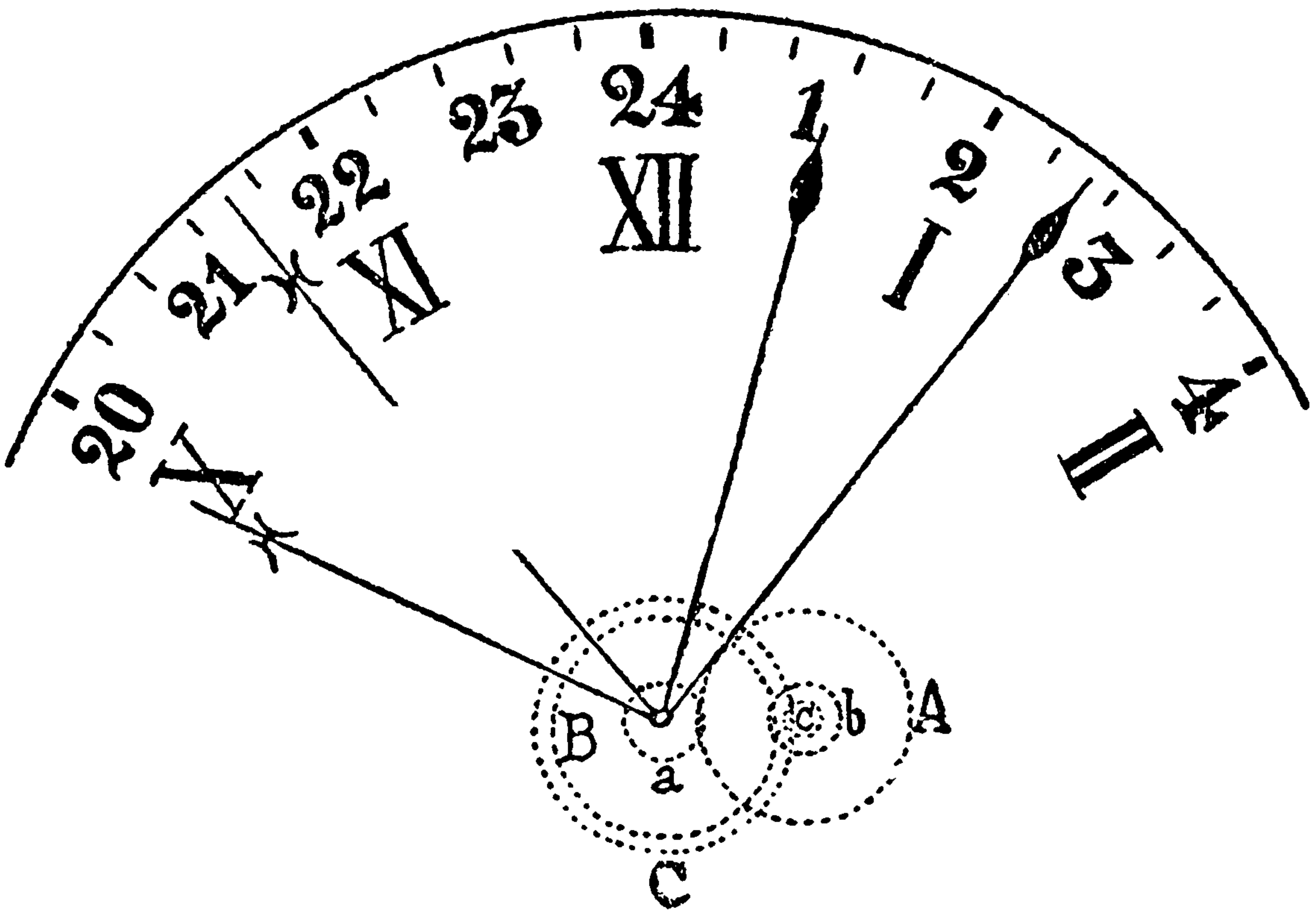

Fig. 30

the same cannon pinion and the same minute wheel for both sets of wheels ; one need only add a second pinion,  $c$ , fastened on top of the first, and gearing in a second hour wheel,  $C$ , loosely fitted on the first wheel.

Admitting for the first train

Cannon pinion 12 leaves, Minute wheel 36 teeth,  
Minute pinion 10 leaves, Hour wheel 40 teeth,

one should have for the first train

$$24 = \frac{36 \times C}{12 \times c}$$



Choosing for  $c$  6 leaves, one will have

$$24 = \frac{36 \times C}{12 \times 6},$$

from whence

$$C = \frac{24 \times 12 \times 6}{36} = 48;$$

one will have correctly

$$24 = \frac{36 \times 48}{12 \times 6}.$$

The two minute hands are fastened on the axis of the center wheel, since in both cases they should execute one turn in an hour; their angle of divergence once being determined, will remain permanent.

**153.** *Calculation of the numbers of teeth in the wheels of an astronomical clock (seconds regulator) which should run 33 days, the weight having a drop of 830 mm. The cord unwinds from a cylinder whose radius is 15 mm., in which is included half the thickness of the cord. This cord is supposed to run through a pulley.*

Solution: Since the cord runs through a pulley, it unwinds from the cylinder a length equal to twice the descent of the weight, therefore, 1660 mm. On dividing this length by the circumference of the cylinder,  $2 \pi r$ , we will obtain the number of turns executed by this cylinder during the descent of the weight; therefore,

$$\frac{1660}{2 \times 3.1416 \times 15} = 17.6 \dots \text{turns.}$$

The cylinder makes, then, 17.6 turns, while the weight descends 830 mm.; or, according to the data, during 33 days, or, again, during  $24 \times 33 = 792$  hours.

One turn of the cylinder will then be effected in

$$\frac{792}{17.6} = 45 \text{ hours.}$$

Consequently, while the wheel fixed on the arbor of the cylinder (fusee wheel) makes one turn, the wheel carrying the minute hand must execute 45.

One sees at once that, in order to avoid having too great a number of teeth, one should introduce an intermediate pinion  $a$  and wheel  $B$  between the fusee and the center wheel (Fig. 31).



In order to determine the numbers of teeth in the fusee and in the intermediate wheel, as well as for the pinions  $a$  and  $b$ , one would employ the equation (3)

$$n'' = n \frac{A B}{a b},$$

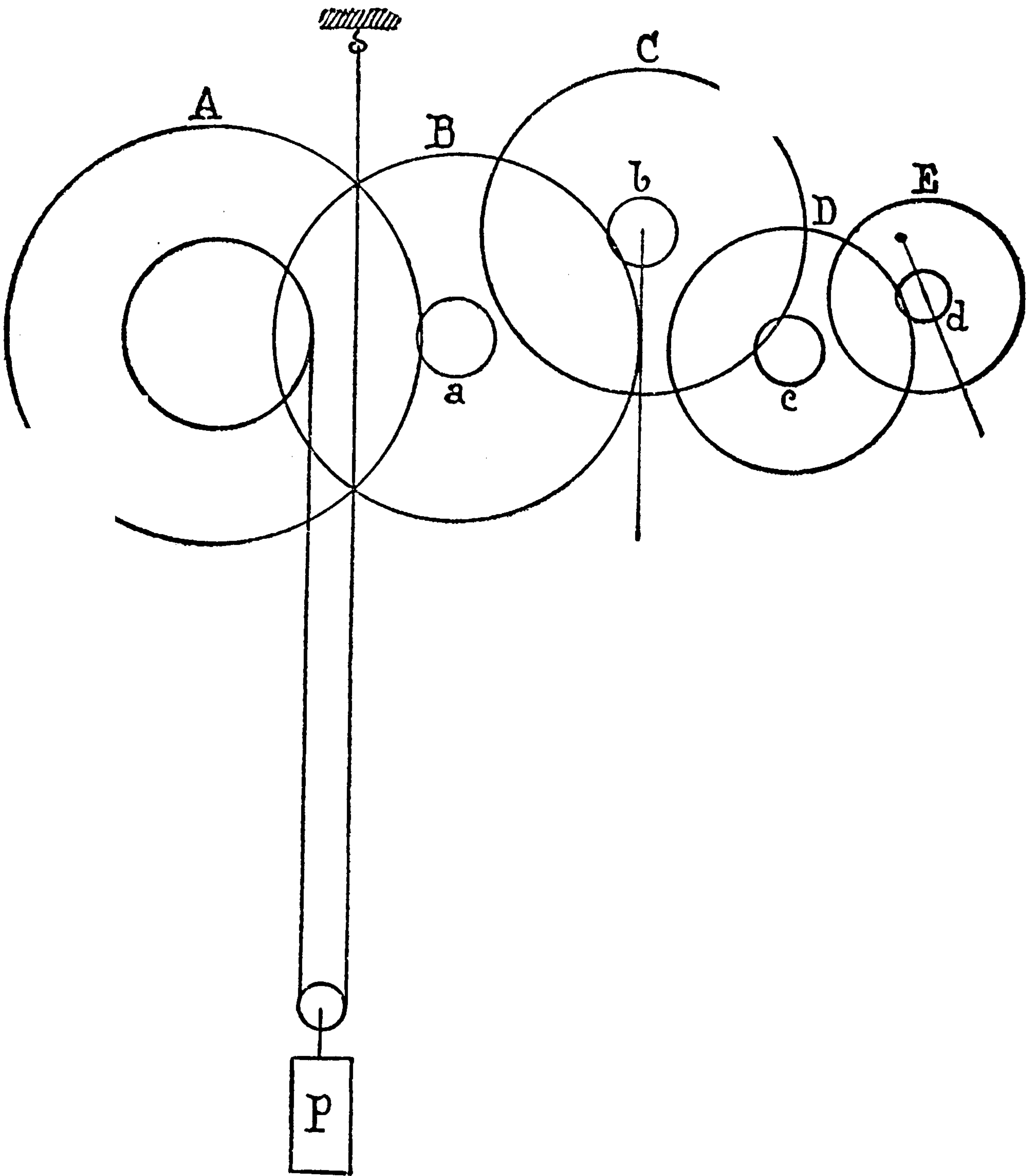

**Fig. 31**

in which  $n'' = 45$  and  $n = 1$ . If we should choose pinions of 18 and 16 leaves, we will place

$$45 \times 18 \times 16 = A B.$$

The first member separated into prime factors gives

$$2^5 \times 3^4 \times 5 = A B,$$





**THIS PAGE IS LOCKED TO FREE MEMBERS**

Purchase full membership to immediately unlock this page

# DELVE INTO FANTASY, MAGIC, MYTHOLOGY & FOLKLORE

Forgotten Books'  
Full Membership gives  
access to 797,885 ancient  
and modern, fiction and  
non-fiction books.

**Continue**

\*Fair usage policy applies



equivalent fraction, having as denominator a whole prime number :

$$\frac{9360}{17.6} = 531\frac{9}{11};$$

multiplying this quotient by 11, one obtains the whole number 5850, then

$$\frac{9360}{17.6} = \frac{5850}{11}.$$

One will have, consequently,

$$\frac{5850}{11} a b c = A B C.$$

In choosing the numbers of leaves for the pinions, care must be taken that 11 is found as factor in one of these numbers, in order to be able to eliminate the denominator. Let us take, then, the figures 22, 16 and 14 ; we will have

$$\frac{5850}{11} \times 22 \times 16 \times 14 = A B C$$

and

$$\frac{2^7 \times 3^2 \times 5^2 \times 7 \times 11 \times 13}{11} = A B C.$$

After cancellation, one could form the following groups :

$$\begin{aligned} A &= 2^6 \times 3 &= 192 \\ B &= 2 \times 5 \times 13 &= 130 \\ C &= 3 \times 5 \times 7 &= 105. \end{aligned}$$

If one found these values too great, one could choose pinions with fewer numbers ; for example, 10, 11 and 12 leaves, and one would have, in an analogous manner,

$$\begin{aligned} A &= 2^3 \times 3 \times 5 &= 120 \\ B &= 2 \times 3 \times 13 &= 78 \\ C &= 3 \times 5^2 &= 75. \end{aligned}$$

For both cases we would have correctly,

$$\frac{192 \times 130 \times 105}{22 \times 16 \times 14} = \frac{120 \times 78 \times 75}{12 \times 11 \times 10} = \frac{5850}{11}.$$

For the other wheels of the train, the case is the same as in the preceding example.

By introducing a third intermediate wheel, one could succeed in making such a clock run for 10 years, but there exist practical disadvantages which make this combination seldom used.

**155.** *How to determine the number of teeth in a third wheel which has been lost, knowing that the balance should beat 18,000 oscillations per hour and knowing the numbers of teeth in the other wheels and pinions ?*



Solution : Let us call  $x$  the unknown number and let the  
 Center wheel have 80 teeth, Third wheel pinion 10 leaves  
 Third " "  $x$  " Fourth " " 10 "  
 Fourth " " 70 " Escape " " 7 "  
 Escape " " 15 "

The formula (8) admits of placing

$$18000 = \frac{80 \times x \times 70 \times 2 \times 15}{10 \times 10 \times 7};$$

or, simplifying,

$$18000 = 240 x,$$

and

$$X = \frac{18000}{240} = 75 \text{ teeth.}$$

The lost third wheel, therefore, had 75 teeth.

**156.** *If, in the preceding problem, the last mobile had been the third-wheel pinion, how would the equation be solved?*

Solution : We would have in an analogous manner :

or

$$18000 = \frac{80 \times 75 \times 70 \times 2 \times 15}{x \times 10 \times 7},$$

$$18000 = \frac{180000}{x}$$

and

$$x = \frac{180000}{18000} = 10 \text{ leaves.}$$

**157.** *Still using the preceding data, let us suppose that the pinion and the escape wheel were both lost, and let us propose to determine their teeth ranges.*

Solution : We will have, in this case, two unknown quantities, which we will designate by  $x$  and  $y$  ; the equation (8) will be written

$$18000 = \frac{80 \times 75 \times 70 \times 2 \times x}{10 \times 10 \times y},$$

from whence

$$18000 = \frac{8400 x}{y}$$

and

$$\frac{18000}{8400} = \frac{x}{y}.$$

On simplifying,

$$\frac{15}{7} = \frac{x}{y}.$$

The wheel, then, should have 15 teeth and the pinion 7 leaves.



**158.** *In the last problem, we arrived immediately at the real numbers; this does not always happen. Let it be desired, as a second example, to find the numbers of teeth and of leaves in a center wheel and a third pinion which have been lost:*

Solution : One has

$$18000 = \frac{x \times 75 \times 70 \times 2 \times 15}{y \times 10 \times 7},$$

from whence one obtains

$$18000 = \frac{x}{y} 2250,$$

and

$$\frac{18000}{2250} = \frac{x}{y};$$

the simplification gives

$$\frac{x}{y} = 8.$$

This result shows us that the center wheel should have eight times as many teeth as the pinion has leaves. On replacing successively  $y$  by 6, 7, 8, 10 and 12 leaves, one will obtain the following solutions :

For $y = 6$	one has	$x = 6 \times 8 = 48$	teeth
“ $y = 7$	“	$x = 7 \times 8 = 56$	“
“ $y = 8$	“	$x = 8 \times 8 = 64$	“
“ $y = 10$	“	$x = 10 \times 8 = 80$	“
“ $y = 12$	“	$x = 12 \times 8 = 96$	“

Several solutions can, therefore, satisfy the demand, and the one which suits best must be chosen ; it is evident, here, that with relation to the numbers of teeth in the other mobiles, a center wheel with 80 teeth and a pinion with 10 leaves are perfectly admissible.

**159. Indicator of the Spring's Development in Fusee Timepieces.** Marine chronometers and a great many fusee watches carry an auxiliary hand placed on the dial, and with its center on a straight line between the point of XII o'clock and the middle of the center wheel. The object of this hand is to indicate, on a small dial, the number of hours which the chronometer has run since it was last wound. It gives notice, thus, of the proper time for rewinding the chronometer, an operation which then brings the hand back to zero.

This mechanism, easy to establish in fusee watches, becomes difficult to introduce in other kinds. Let us take up the first for the present.





**THIS PAGE IS LOCKED TO FREE MEMBERS**

Purchase full membership to immediately unlock this page

# HISTORY

Tens of thousands of important historical sources, many previously unobtainable, are now available for the first time with a Forgotten Books Full Membership.

Unlimited Access  
\$8.99/month

**Continue**

\*Fair usage policy applies





It may happen that, owing to the arrangement of the calibre of the watch, one could not make the pinion gear directly in the wheel ; it would be necessary in this case to place a second wheel gearing on one side in the fusee pinion, and on the other in the wheel carrying the hand. This last mobile will then take a movement to the left, and if one wished to avoid that, it would be necessary to arrange two intermediate wheels between the wheel  $A$  and the pinion  $a$ .

Let us note that the number of teeth in this or in these intermediate wheels does not modify the relation existing between the movement of the wheel  $A$  and that of the pinion  $a$ . Designating by  $B$  the number of teeth in the intermediate wheel, one has

$$\frac{n'}{n} = \frac{A B}{a B} = \frac{A}{a}.$$

**160. Simple Calendar Watches.** By this name we designate a certain class of watches having an accessory mechanism by means of which is shown, on the dial of the watch, the date, the day of the week and the name of the month. These indications are made by means of hands fixed on the axes of toothed wheels, performing their revolution in the length of time desired ; that is to say, the hand indicating the date jumps each day at midnight, as does also the one indicating the day of the week. These movements are obtained by means of a wheel making one rotation in twenty-four hours. The dial showing the date is divided into thirty-one parts ; the hand jumps, therefore, for months of thirty-one days from the figure 31 to the figure 1. If the month has only twenty-eight, twenty-nine or thirty days, the hand should be set to the figure 1 by hand. This is inconvenient and is overcome in perpetual calendars, but such mechanisms are, therefore, more complicated.

Calendar watches are often made to indicate also the phases of the moon. An opening is made in the dial for this purpose, across which pass successively representations of the various appearances which the moon presents. The movement of this satellite is not continuous, as in nature, but intermittent ; it is produced each day, as are the other actions of the calendar.

Let us examine now in what manner the different movements which we have just mentioned, are effected (Fig. 33).

The most simple construction consists in placing a wheel of 30 teeth on the hour wheel ; this wheel gears in two other wheels,



*B* and *C*, of 60 teeth each. These last mobiles execute, therefore, one revolution in 24 hours. The wheel *B* carries a pin *m* perpendicular to its plane, which comes into gear at each rotation with the teeth of a "star" of 31 teeth carrying the calendar hand. This

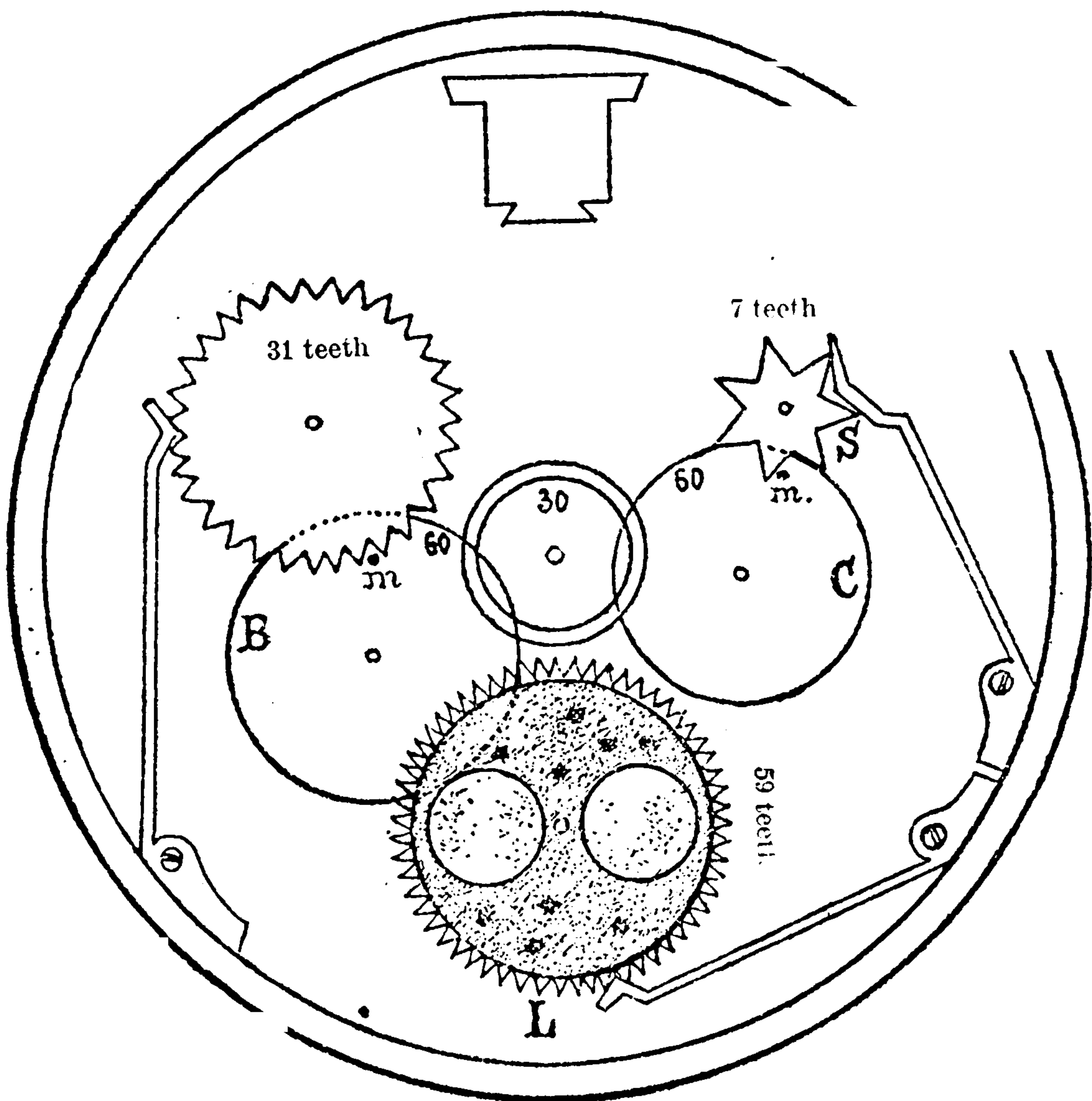

Fig. 33

last wheel is kept in place by a jump-spring. During the day this same pin makes the phase wheel *L* jump in the same manner. This wheel, also star-shaped, contains 59 teeth; it is in like manner kept in place by a jumper; on its surface are represented two moons diametrically opposed. When one of the faces disappears behind the dial at the time of the new moon, the edge of the following is on the point of appearing in the shape of a slight crescent.

A synodical revolution of the moon (interval comprised between two consecutive full moons) is effected in very nearly 29 days and a half;\* two lunations require about 59 days. This is the reason why 59 teeth are given to the phase wheel.

\* Exactly, 29 days, 12 hours, 44 minutes.



The second wheel  $C$  also carries a pin, intended to make the wheel  $S$ , with 7 teeth, jump ; this wheel carries the hand indicating the days of the week.

The movement of the hand which indicates the month, is most generally effected by setting it by means of an exterior push-piece. This hand is carried by a star wheel with 12 teeth, which is kept in place during one month by a jump-spring similar to those of the other stars.

It does not require, therefore, much calculation in order to determine the tothing of these different wheels.

*161. Suppose it be desired to determine the numbers of teeth and leaves of the wheel-work in a decimal watch, desiring to preserve to the balance wheel of this mechanism the same duration of oscillation as in that of an ordinary watch.*

Solution : A decimal watch is an instrument dividing the length of a day into twenty parts, in place of twenty-four ; therefore, the interval included between a midnight and a midday, or a midday and the following midnight, into ten equal parts. Each of these "hours" is divided into 100 "minutes."

Let us further make this a condition : this watch should run just as long as an ordinary watch (32 duodecimal hours). An ordinary watch, furnished with the customary stop-works, can run  $1\frac{1}{3}$  days while its barrel makes four turns ; this barrel will execute, therefore, 3 turns in a day. In a decimal watch, the center wheel should, accordingly, make 20 rotations while the barrel makes 3.

While this barrel makes 1 turn, the center wheel will make

$$\frac{20}{3} = 6\frac{2}{3} \text{ turns.}$$

One will, therefore, have

$$6\frac{2}{3} = \frac{A}{a}.$$

Choosing a pinion  $a$  with 12 leaves, a multiple of the denominator of the fraction, it will become

$$6\frac{2}{3} \times 12 = A,$$

from whence

$$A = 80.$$

The barrel would, therefore, have 80 teeth and the center pinion 12 leaves (Fig. 34).





**THIS PAGE IS LOCKED TO FREE MEMBERS**

Purchase full membership to immediately unlock this page

# DELVE INTO FANTASY, MAGIC, MYTHOLOGY & FOLKLORE

Forgotten Books'  
Full Membership gives  
access to 797,885 ancient  
and modern, fiction and  
non-fiction books.

**Continue**

\*Fair usage policy applies



fourth wheel makes one, will be obtained by dividing 216 oscillations by twice the number of teeth in the escape wheel, therefore,

$$\frac{216}{2 \times 15} = 7\frac{1}{5} \text{ turns.}$$

One, therefore, places

$$7\frac{1}{5} = \frac{D}{d},$$

and, on choosing for the number of leaves a multiple of 5, 10, for example, one will have

$$\begin{aligned} 7\frac{1}{5} \times 10 &= D, \\ D &= 72 \text{ teeth.} \end{aligned}$$

The fourth wheel could have 72 teeth and the escape pinion 10 leaves.

**162.** In the problem with which we have just dealt, the second hand will not divide the minute into 100 parts, since it will make 216 little jumps during one revolution. We could still propose to divide the minute into 100 equal parts, by abandoning the condition stipulated in the first problem, of keeping for the balance the same duration of oscillations; in place, therefore, of making it execute 216 oscillations, let us imagine it as making 200 of them.

With an escape wheel of 15 teeth, one arrives at

$$\frac{200}{2 \times 15} = 6\frac{2}{3} \text{ turns}$$

executed by the escape wheel while the fourth wheel made 1.

Choosing a pinion of 9 leaves, one has

$$6\frac{2}{3} \times 9 = 60 \text{ teeth}$$

for the fourth wheel.

**163.** We have still to make the calculation of the wheel-work for the dial wheels. This problem can have two forms: the one in which the hour hand should execute 1 turn a day, and the one in which it should make 2.

In the second case, the minute hand will make 10 turns while the hour hand makes 1; one will, therefore, write

$$10 = \frac{A B}{a b};$$

with pinions of 12 leaves each, one will have

$$10 \times 12 \times 12 = A B;$$

on reducing into prime factors,

$$\text{From whence} \quad 2^5 \times 3^2 \times 5 = A B.$$

$$\begin{aligned} A &= 2^3 \times 5 = 40 \text{ teeth} \\ B &= 2^2 \times 3^2 = 36 \text{ "} \end{aligned}$$



If the hour hand should only make one turn a day, one then has

$$20 = \frac{A B}{a b}.$$

Taking  $b = 10$  and  $a = 8$  :

$$20 \times 10 \times 8 = A B,$$

or

$$2^6 \times 5^2 = A B.$$

One could then form the two groups

$$\begin{aligned} A &= 2^3 \times 5 = 40 \\ B &= 2^3 \times 5 = 40. \end{aligned}$$

The minute and hour wheels would each have 40 teeth in this case.

**164. Calculation of the Numbers comprising the Teeth-ranges of the Wheels of a Watch with Independent Second Hand.** These

watches, which were constructed in considerable numbers some years ago, generally contained two distinct trains. In this system a special hand is placed at the center of the dial and makes one jump only per second ; it can be arrested for an indefinite time, then started again at will, without stopping the watch. The office of this second train is to drive this independent second hand. The principle of the mechanism is, therefore, to release, at each second, the train which brings the hand into action. For this purpose the last pinion of the second train carries on its axis an arm

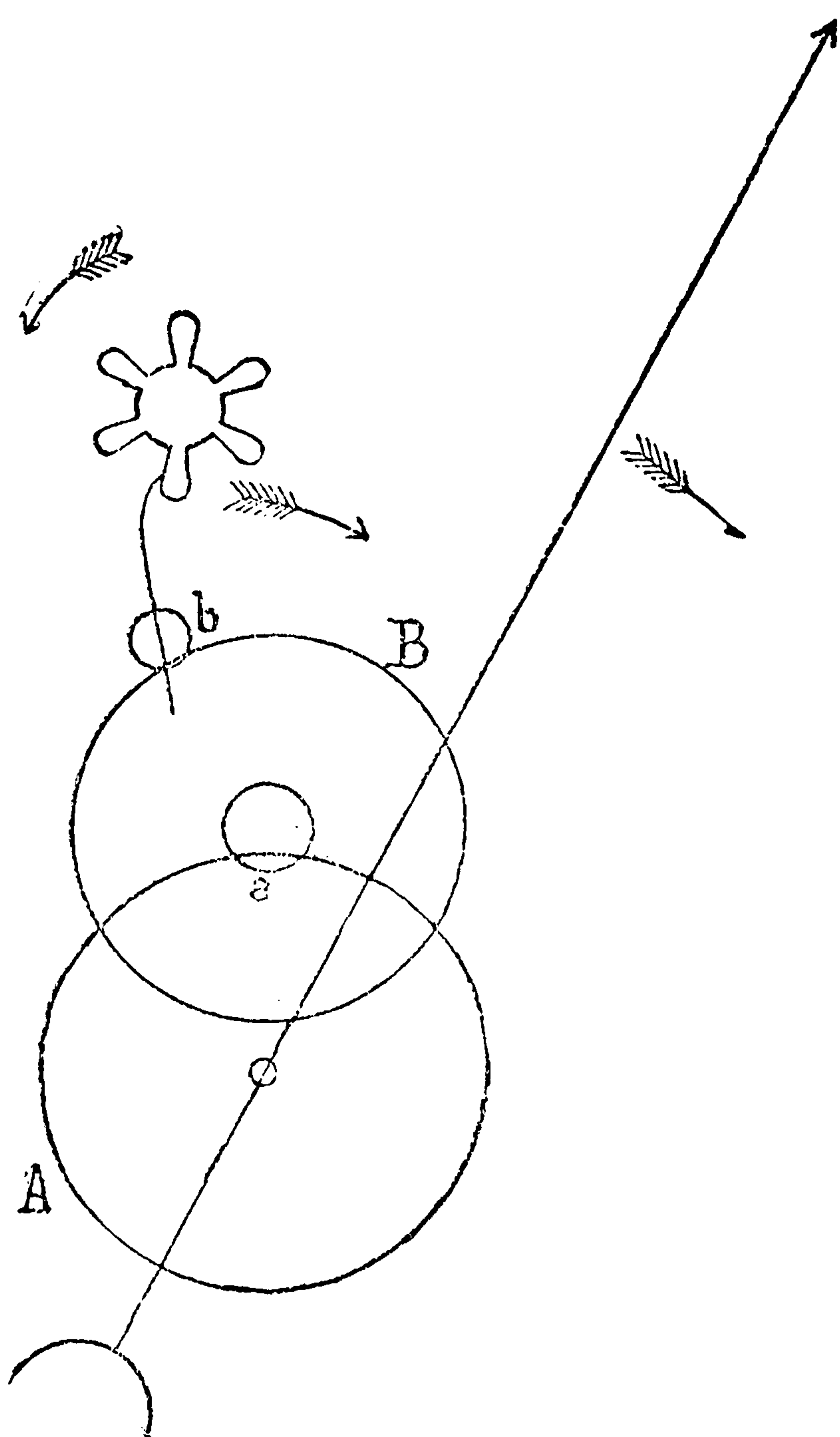

Fig. 35



called the "whip," gearing either directly in the escape pinion of the first train or in a "star" adjusted on the axis of this latter (Fig 35).

While the whip is in contact with a leaf of the escape pinion, it has a slightly-pronounced angular movement, scarcely perceptible on the second hand. But when the leaf of the pinion has advanced up to a certain point, the whip becomes free and rapidly makes almost a complete turn and again comes in contact with the pinion on the next leaf. At each turn of the whip the second hand should advance one division on the dial. At each second, therefore, a leaf of the pinion or a tooth of the star must present itself to receive the whip.

A lever or a cylinder escapement, whose wheel advances at each vibration of the balance, half the space which separates two consecutive teeth, can serve for this purpose, if the number of oscillations is 18,000 per hour, therefore, 5 per second. In effect, a wheel with 15 teeth produces 30 oscillations and requires, therefore,

$$\frac{30}{5} = 6 \text{ seconds}$$

to make one turn.

If one causes the whip to gear directly into the pinion, the latter should have 6 leaves ; if not, it would be necessary to fasten a star with 6 teeth, on its axis, into which the whip should be made to gear. The movement will then be effected according to the requirements.

There is a remark to be made about watches provided with the detent or duplex escapements.

During the vibration in which the wheel gives the impulse to the balance, this wheel advances an angle equal to that which separates two consecutive teeth, and during the succeeding oscillation it remains at rest. Owing to this fact each tooth still produces two oscillations ; but we cannot then allow the balance to make 18,000 oscillations, because the whip should become free at the end of every five vibrations and, the figure 5 being an odd number, there would be found, every two seconds, a vibration without an impulse, during which the whip could not be released. Watches provided with either system of escapement, should, therefore, in order to be used as independent seconds, beat an even number of vibrations per second : 14,400 or 21,600 per hour, either 4 or 6 per second.





**THIS PAGE IS LOCKED TO FREE MEMBERS**

Purchase full membership to immediately unlock this page



# HISTORY

Tens of thousands of important historical sources, many previously unobtainable, are now available for the first time with a Forgotten Books Full Membership.

Unlimited Access  
\$8.99/month

**Continue**

\*Fair usage policy applies



**165.** If the watch has a *double set of dials*, that is to say, if the dial is subdivided into two small dials, the hour and minute hands of which can indicate two different times, the pinion gearing in the barrel of the independent second train carries a minute hand on the extension of its axis, as does that of the center wheel in the trains generally used. A set of dial wheels is added to each train, and one thus possesses the means of making the watch indicate simultaneously the time of two different countries. In this case the wheel which has  $D$  teeth should make one turn per hour while the pinion, which has  $e$  leaves, carrying the second hand, makes 60. The preceding figures fulfill precisely this condition, since one has, correctly,

$$60 = \frac{D E}{d e} = \frac{64 \times 60}{8 \times 8}.$$

**166.** The arrangement of watches called *fifths* or *quarter seconds* is similar to that of the independent seconds ; but one could only construct such with an escapement whose wheel advances a half tooth at each vibration, since the star that is adjusted on the last pinion of the second train should become free at each vibration of the balance. One could not, therefore, employ in either of these systems, detent or duplex escapements. Fifths of seconds watches should beat 18,000 oscillations and the star of the escape wheel should present a tooth at each vibration ; this star should, therefore, have twice the number of teeth that the escape wheel has. Since this last generally has 15, the star should have 30. In place of the whip, another star, with 5 teeth, is adjusted on the axis of the last pinion of the second train.

Quarter seconds watches should beat 14,400 vibrations ; the star of the escape pinion should have the same number of teeth as the wheel, and the star on the last pinion of the second train should have 4 teeth.

The numbers of teeth in the other wheels are the same as for the independent seconds.

**167.** Let us remark that these systems are out of date to-day and that they are replaced by the *chronographs*. These mechanisms are simpler and consequently cost less ; they are based on entirely different principles, having no connection with the kind of problems of which we treat now.

**168.** *Required, to find the number of turns which one should give to the winding stem, on setting a watch, to make the minute hand move once round the dial.*



**Solution :** Given the following numbers of teeth for the wheel in action.

Cannon pinion,	12 leaves	Minute wheel,	30 teeth
Main setting wheel,	27 teeth	Small setting wheel,	18 "
Sliding pinion,	16 "	(Fig. 36).	

Since it is desired to know the number of turns which the winding stem makes while the cannon pinion makes one, this cannon pinion must, therefore, be regarded as the driving wheel. The minute wheel, which is driven by the cannon pinion, drives in

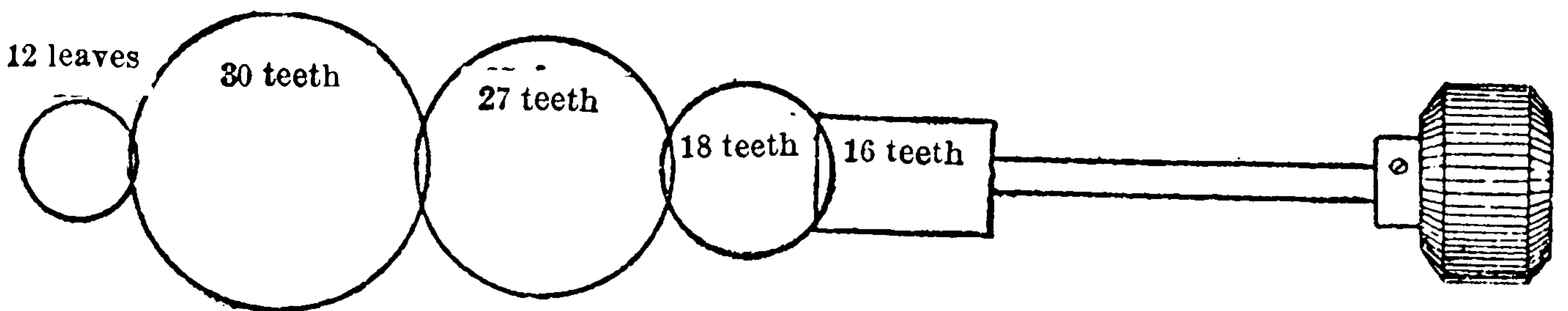

Fig. 36

its turn the main setting wheel ; it is, therefore, a pinion with relation to the cannon pinion considered as a wheel and a wheel with relation to the setting wheel considered as a pinion. The same thing takes place for the large and small setting wheels, which also drive and are driven. One should, therefore, have

$$n = \frac{12 \times 30 \times 27 \times 18}{30 \times 27 \times 18 \times 16} = \frac{12}{16} = \frac{3}{4}.$$

The winding stem must, therefore, be made to execute  $\frac{3}{4}$  of a turn, in order that the minute hand may make 1 turn.

One sees that the numbers of teeth in the intermediate wheels between the cannon pinion and the sliding pinion do not influence at all the result, and that the movement takes place as if the sliding pinion geared directly into the cannon pinion. We have, moreover, already established this fact when dealing with problem 159.

**169.** *Let us now seek the number of turns that one should give to the winding stem to wind up a watch which has run a day (24 hours).*

**Solution :** This question deals with the calculation of the number of turns which the winding pinion should make while the ratchet fastened on the barrel arbor makes 3.

Admit the following numbers of teeth :

Ratchet wheel	44 teeth	Crown wheel	42 teeth
Crown wheel, lower side,	38 "	Winding pinion	18 "



One will have, in this case (Fig. 37), and in an analogous manner to the preceding example

$$n = 3 \frac{44 \times 38}{42 \times 18} = 6 \frac{40}{63} \text{ turns.}$$

It is generally desired to have this number as large as possible, for the reason that the effort which must be made to wind up the main-spring, being a determined mechanical work, the force which must be

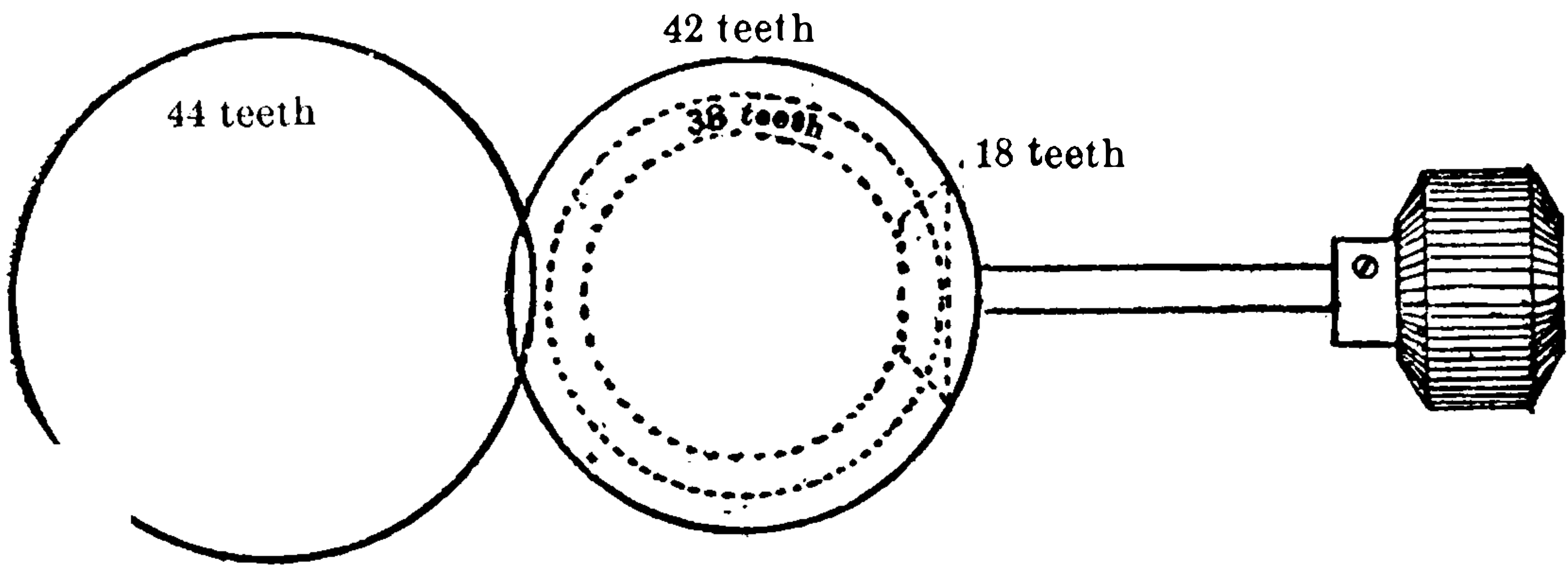

Fig. 37

exerted to wind the watch, will be diminished by increasing the distance traversed. One sees that the number  $n$  becomes greater when we increase the number of teeth in the ratchet wheel and what are called the "crown" teeth in the crown wheel, or when we diminish the other teeth in the crown wheel and those of the winding pinion.

**169 a. Calculation of the Train in a Watch of the Roskopf Type.**

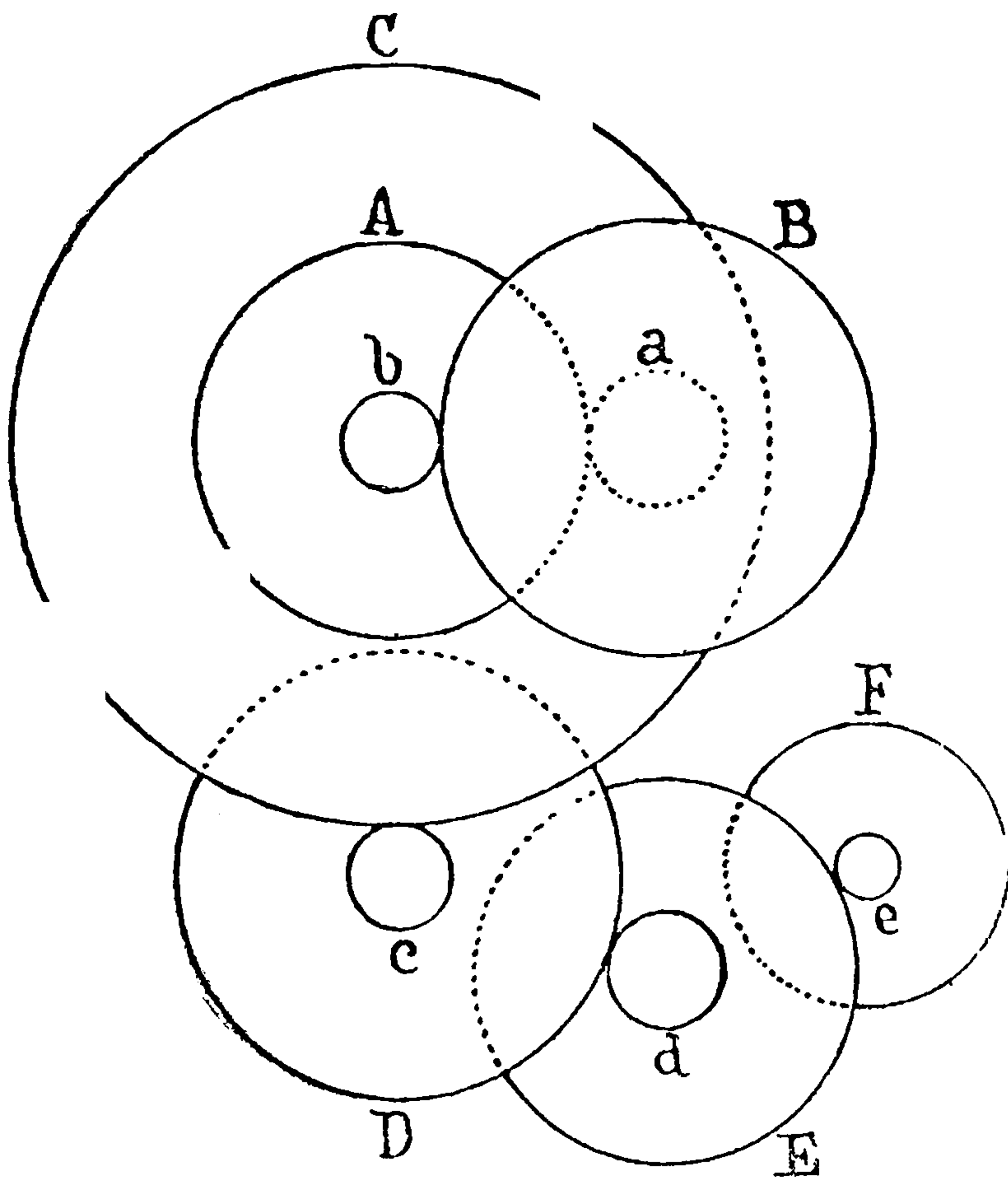

Fig. 37a

Watches of this kind have a simplified train, inasmuch as their barrel gears directly into the third wheel. The movement of the hands is produced by the gearing of a wheel  $A$  (Fig. 37 a) concentric with the barrel and a cannon pinion  $a$  placed on a tenon fastened at the center of the movement. The wheel  $A$ , moreover, carries a pinion  $b$ , gearing in the hour wheel  $B$ . The wheels carrying the hour





**THIS PAGE IS LOCKED TO FREE MEMBERS**

Purchase full membership to immediately unlock this page

# DELVE INTO FANTASY, MAGIC, MYTHOLOGY & FOLKLORE

Forgotten Books'  
Full Membership gives  
access to 797,885 ancient  
and modern, fiction and  
non-fiction books.

**Continue**

\*Fair usage policy applies



Let us admit, as in the preceding case, that the barrel makes one turn in four hours. We will have

$$16200 = \frac{C D E 2 F}{4 c d e}.$$

Choosing pinions of 8, 7 and 6 leaves, one will have

$$16200 \times 2 \times 8 \times 7 \times 6 = C D E F,$$

and on reducing the first member into prime factors,

$$2^8 \times 3^5 \times 5^2 \times 7 = C D E F,$$

with which we could form the following groups :

$$\begin{aligned} C &= 2^3 \times 3 \times 5 = 120 \text{ teeth} \\ D &= 2^2 \times 3 \times 7 = 84 \text{ " } \\ E &= 2^2 \times 3 \times 5 = 60 \text{ " } \\ F &= 2 \times 3^2 = 18 \text{ " } \end{aligned}$$

The train of the dial wheel should give

$$\frac{A B}{a b} = 12.$$

Choosing  $a = 22$  and  $b = 18$ , one has

$$\begin{aligned} A B &= 12 \times 22 \times 18 \\ A B &= 2^4 \times 3^3 \times 11, \end{aligned}$$

from whence, for example,

$$\begin{aligned} A &= 2^3 \times 3^2 = 72 \text{ teeth} \\ B &= 2 \times 3 \times 11 = 66 \text{ " } \end{aligned}$$



## CHAPTER IV.

### Gearings.

**170. Definition.** The theory of gearings has for its object the study of the transmission of the mechanical work from one wheel to another.

**171.** Let us suppose, at first, that we have only one wheel gearing in a pinion and that in place of the complicated force of the spring we have a weight  $P$  (Fig. 38) acting through the medium of a thin and flexible cord on a cylinder whose radius is equal to the unit and which is fastened concentrically to the axis of the wheel.

Let us, at the same time, admit that the resisting force be represented by a weight  $Q$  suspended in the same manner as  $P$  from a cylinder adjusted on the axis of the pinion and with a radius equal to the unit. In further imagining this system animated with a uniform movement, the gearing will be perfect if, at no matter what instant of the movement, the work of the force  $P$  is equal and in the contrary direction to the work of the force  $Q$ , the relation of the forces  $P$  and  $Q$  being properly established.

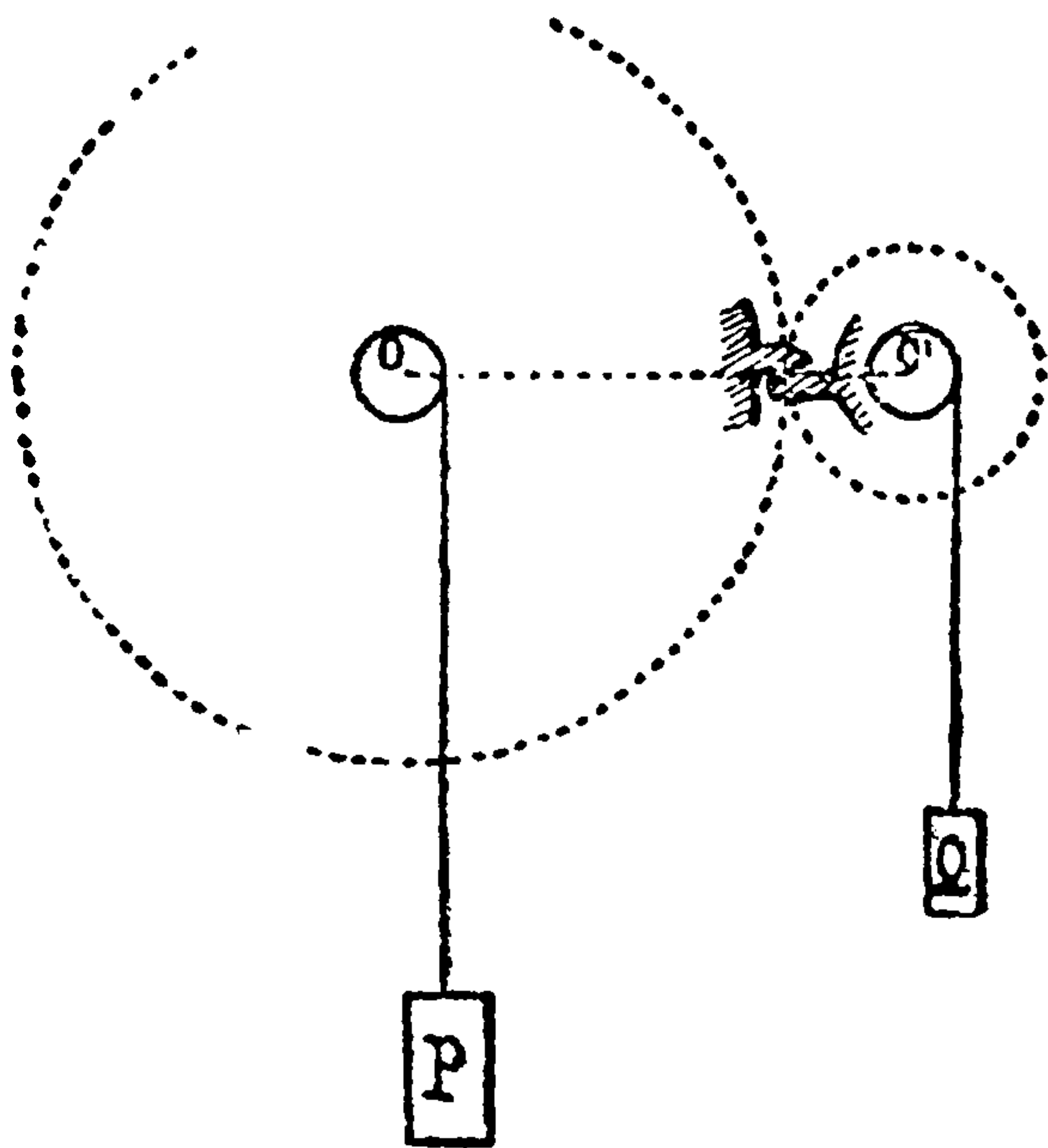

Fig. 38

Since these forces are in the same direction as the path traversed by their point of application, the mechanical work effected, is measured by the product of the intensity of these forces by the distance traversed (37).

If the relation of the forces  $P$  and  $Q$  is correctly chosen, their degree may be arbitrary, and, consequently, they can be supposed as very small or even as nothing. Therein is the basis of the important theory explained in kinetics.

**172.** One can also exclude the movement and devote oneself more especially to the transmission of the force.

We will examine the gearings from this double point of view.



**173. Practical Examination of a Gearing.** Let us place a wheel and a pinion in a *depthing tool*, in such a manner that the two movers may be sufficiently free, but without play between the points of the instrument. Regulate the distance between the two movers until the movement of the wheel produces that of the pinion. Impart then a rapid movement to the wheel : we will establish a good gearing if the movers conserve this motion long enough, and without any other noise than a certain hissing sound easily recognized. The movement imparted should, moreover, diminish gradually and not abruptly. Let us remark that, in order that this experiment may succeed properly, the pinion should be furnished with a wheel, performing the office of a “fly,” so that the movement may continue long enough. One can also examine a gearing from this point of view by placing the movers in the watch and proceeding in the same manner. We have thus decided whether or not the gearing transmits the movement properly ; let us now see if it transmits the force correctly.

Let us use, as in the previous case, the *depthing tool*, and place in the same manner the movers between the arms of the instrument. Let us then create a resisting force acting on the pinion, and, for this purpose, let us press tightly together the points between which the pinion is placed. The gearing will be found established in proper conditions if, after imparting a movement to the wheel, one feels no jerks in the transmission and has only the resistance of friction to overcome.

It is necessary also to assure oneself of the “play” existing between the teeth of the wheel and the leaves of the pinion and of the proper space between the points of the teeth and the bottom of the pinion’s leaves.

When the gearing is placed in the watch movement one can create a resisting force by pressing the end of a wooden peg against the end of one of the pivots of the pinion ; on causing the wheel to turn with the aid of another peg, one could assure oneself, as in the preceding case, of the qualities of the gearing considered.

**174.** Let us observe that when a gearing transmits the movement properly, it transmits equally well the force, and when one of these conditions is fulfilled the other is, also. It is, however, good, for a careful examination, to use the two methods, for certain defects make themselves felt more readily by one than by the other of the two modes.





**THIS PAGE IS LOCKED TO FREE MEMBERS**

Purchase full membership to immediately unlock this page



# HISTORY

Tens of thousands of important historical sources, many previously unobtainable, are now available for the first time with a Forgotten Books Full Membership.

Unlimited Access  
\$8.99/month

**Continue**

\*Fair usage policy applies



has accomplished a number of rotations  $c$ , the wheel  $O'$  has made a number  $c'$  and one would have the new relation,

$$(2) \quad \frac{c}{c'} = \frac{r'}{r}.$$

**177.** Although the transmission of mechanical work by simple contact may not be employed in horology, at least in a direct manner, one finds, however, numerous applications in the work of the practical man. In these cases the wheels are not ordinarily in contact; a certain space separates them, and to produce the movement of driving one by the aid of the other, we wrap around them both either a cord, or, perhaps, a leather strap called "the band."

Thus, for example, the cord of a foot-wheel or hand-wheel in the watchmaker's lathe transmits the movement, it may be, to a counter-shaft, or directly to a pulley mounted on the lathe; the bow string transmits, likewise, the mechanical work produced by the hand, which gives motion to it, to the pulley around which this cord is wrapped.

**178.** Let us examine, in the first place, the case of two pulleys connected by a cord or band (Fig. 40). Let us first establish the

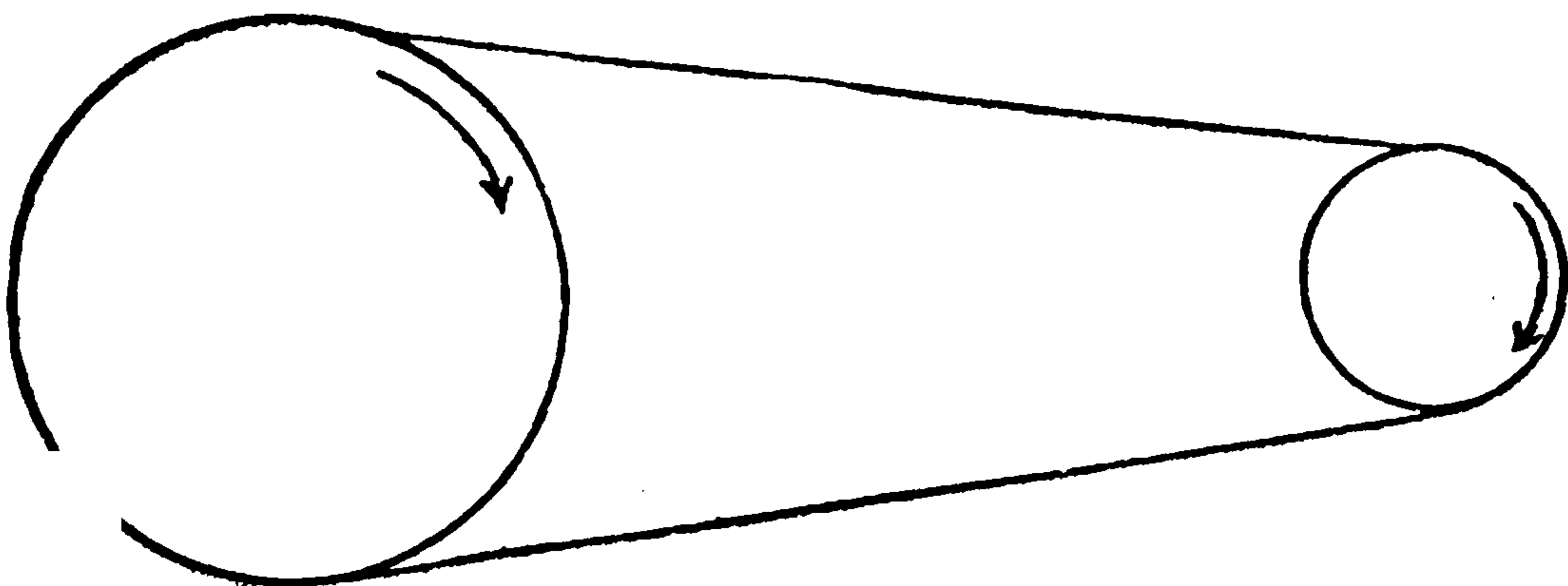

Fig. 40

fact that, if the two sides are not crossed, the two wheels turn in the same direction; if they are crossed (Fig. 41), the wheels turn in contrary directions.

The angle  $\alpha$  corresponding to 1 turn of the first pulley is equal to  $2\pi$ ; for  $n$  turns it is  $2\pi n$ .

The same for the second pulley: the angle  $\alpha'$  is equal to  $2\pi$  for 1 turn and to  $2\pi n'$  for  $n'$  turns.

One can then write

$$\frac{2\pi n}{2\pi n'} = \frac{r'}{r} = \frac{n}{n'}.$$



When  $n$ ,  $r$  and  $r'$  are known, one has for  $n'$

$$n' = n \frac{r}{r'},$$

and if, as is generally the case,  $n$  is equal to 1, one has simply

$$n' = \frac{r}{r'}.$$

The number of turns executed by the second pulley while the first makes 1 is then equal to the relation between the radii of the two wheels.

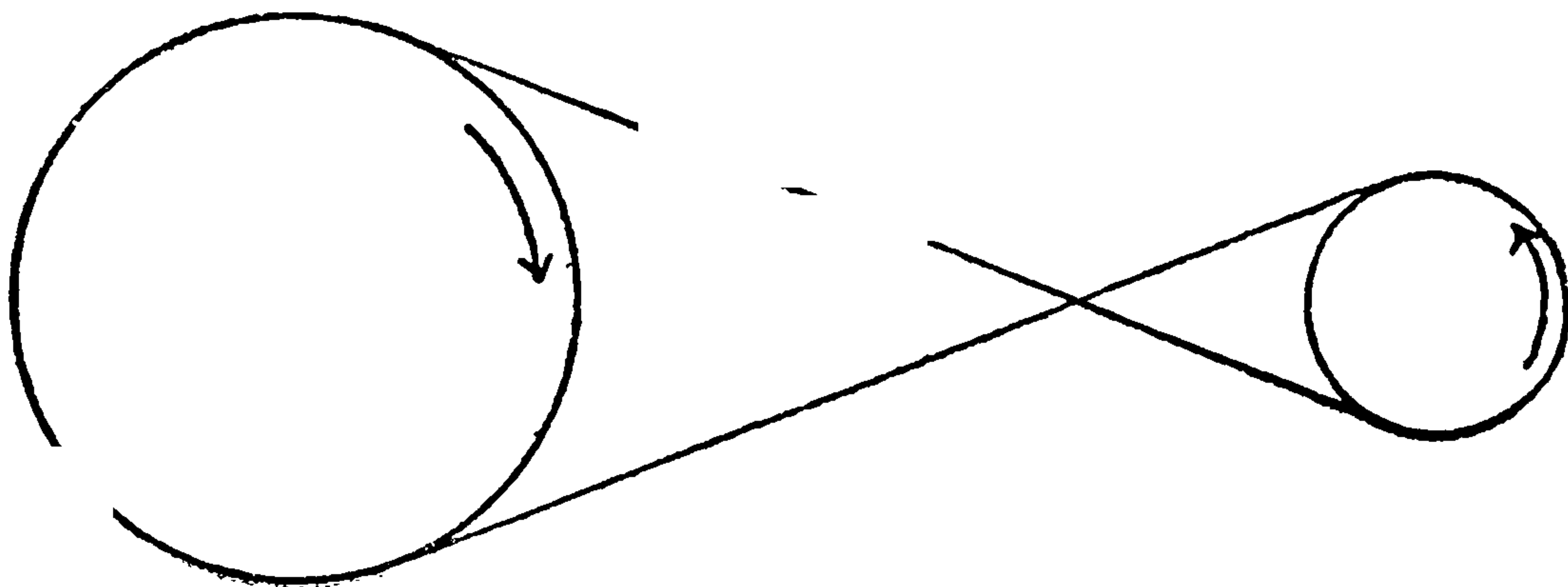

Fig. 41

**179. Applications.** *An arbor makes 100 turns to the minute; it is furnished with a pulley whose diameter is equal to 0.70 m. A band transmits its movement to a pulley of 0.40 m. diameter placed on a second arbor. One desires to know the number of turns made by the second pulley.*

We will have from the preceding relation

$$n' = \frac{100 \times 0.70}{0.40},$$

since

$$n = 100; 2r = 0.70 \text{ and } 2r' = 0.40,$$

then, performing the calculations,

$$n' = 175 \text{ turns.}$$

*A pulley of 0.80 m. diameter executes 90 turns to the minute, what should be the diameter of the pulley driven, knowing that it should execute 160 turns during the same time?*

The formula

$$\frac{r'}{r} = \frac{n}{n'}$$

can be just as well written

$$\frac{2r'}{2r} = \frac{n}{n'},$$



and from thence one establishes

$$2 r' = 2 r \frac{n}{n'} ;$$

in figures

$$2 r' = \frac{0.80 \times 90}{160},$$

and performing the calculations

$$2 r' = 0.45 \text{ m.}$$

**180.** It often happens that a tool, such as a lathe, a counter-sink, or a drill, should run at different speeds, in order to satisfy the necessities of the work. One installs then on the driving arbor a multiple pulley, tapered pulley or speed cone. On the driven arbor is likewise found a similar pulley, but always in the contrary manner. It is only necessary then for one cord to be placed on the different pairs of pulleys which correspond. The sum of the radii of two corresponding pulleys should then be constant.

**181.** Let us now suppose the case of a foot-lathe. The cord of the large wheel is wrapped around the groove of a counter-shaft pulley and transmits the movement to this counter-shaft. Another cord is wrapped around another groove of the same counter-shaft, but of a different radius, and transmits the movement of the arbor to the pulley fastened on the lathe. What is the relation between the number of turns of the first wheel and that of the last?

Let us designate in a general manner

the number of turns of the large wheel by	. . .	n
“ “ “ “ “ counter-shaft by	. . .	n'
“ “ “ “ “ pulley of the lathe by	. . .	n''
“ radius of the large wheel by	. . . . .	R
“ “ “ small groove of the counter-shaft by	. . . . .	R'
“ “ “ large “ “ “ “ “	. . . . .	r
“ “ “ small “ “ pulley by	. . .	r'
“ “ “ large “ “ “ “	. . .	r''

We then have (Fig. 42)

$$n' = n \frac{R}{R'},$$

and, in like manner,

$$n'' = n' \frac{r}{r'} ;$$

or, replacing  $n'$  by its value,

$$n'' = n \frac{R}{R'} \times \frac{r}{r'}.$$

Since, in this first case, the wheel drives the small pulley of the counter-shaft, and the large pulley of the counter-shaft drives





**THIS PAGE IS LOCKED TO FREE MEMBERS**

Purchase full membership to immediately unlock this page

# DELVE INTO FANTASY, MAGIC, MYTHOLOGY & FOLKLORE

Forgotten Books'  
Full Membership gives  
access to 797,885 ancient  
and modern, fiction and  
non-fiction books.

**Continue**

\*Fair usage policy applies



**183.** The transmission of force by the means of wheels, or rolling cylinders driving each other by simple contact, can scarcely ever be employed in practice, because the adhesion, called "force of friction," is very slight; the limit being passed, slipping is produced.

To obviate this inconvenience, one inserts in the wheel projec-

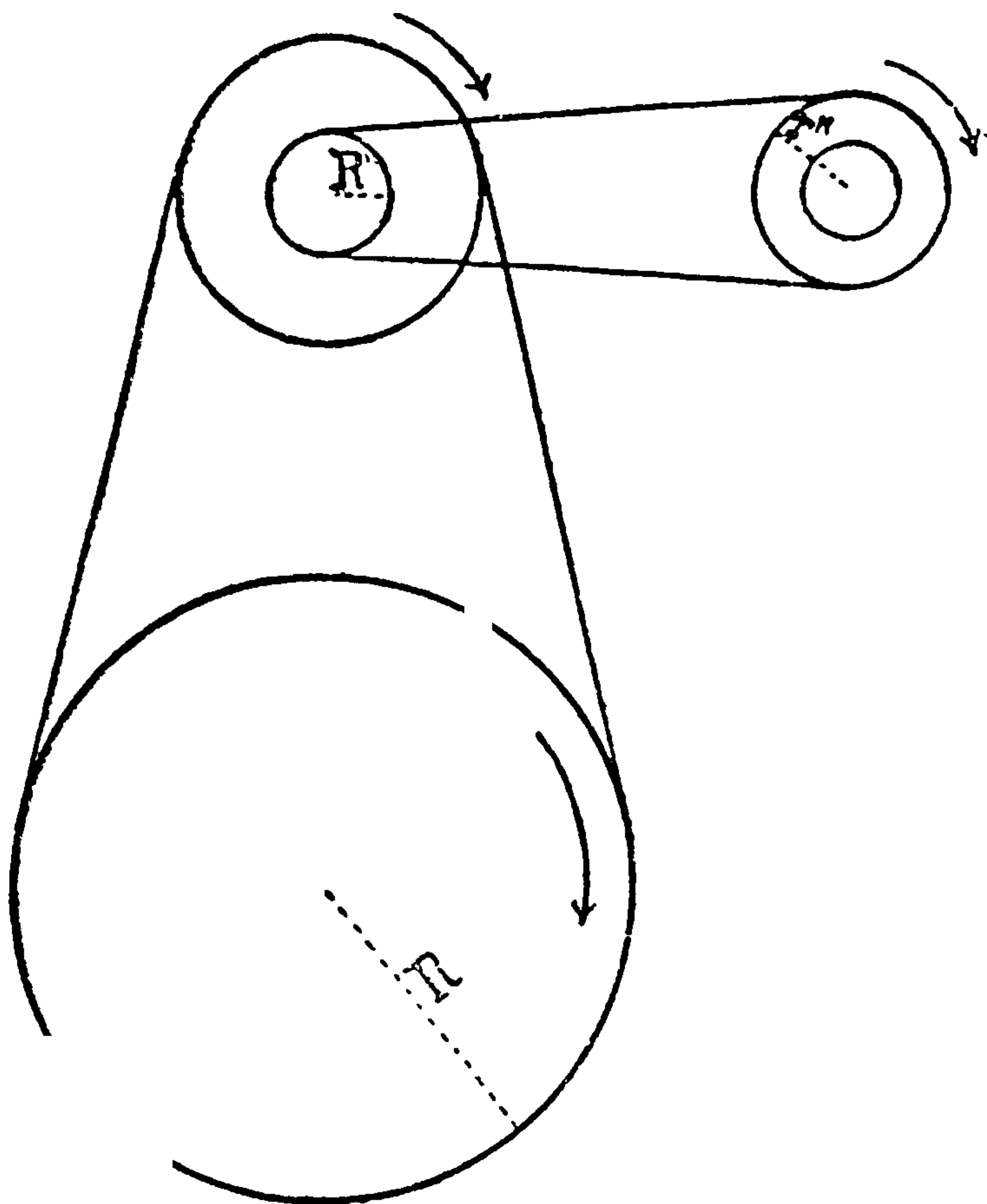

Fig. 43

tions, which are the *teeth*, gearing in the openings contrived in the pinion. One then forms what has been called the *leaves* of the pinion. With this arrangement the movement of the two toothed wheels should be made in an identical manner to that of the cylinders first considered.

It, therefore, follows that in a gearing one can always imagine two circumferences driving each other by simple contact, and in the same conditions of movement. These circumferences bear the name of *primitive circumferences*.

**184.** One calls the *pitch of the gearing* the length of the arc measured on the primitive circumference of one of the wheels, extending from a point of one tooth to the similar point of the tooth which follows. The pitch of the gearing should then comprehend the space occupied by a whole and a blank of a tooth.

The pitch of the gearing of the wheel should be equal to that of the pinion which it drives. Let us designate this pitch by the letter  $p$  and call, moreover, the number of teeth in the wheel  $n$ , and the number of leaves in the pinion  $n'$ .

The length of the primitive circumference of the wheel,  $2 \pi r$ , should then be equal to  $p \times n$ , since the pitch ought to be contained  $n$  times in this circumference.

For the same reason the length of the primitive circumference of the pinion,  $2 \pi r'$ , should be equal to  $p n'$ .



In order to obtain a relation between the primitive radii and the numbers of teeth, let us divide the equation

$$2 \pi r = p n$$

by

$$2 \pi r' = p n'$$

we will obtain

$$\frac{2 \pi r}{2 \pi r'} = \frac{p n}{p n'};$$

or, after simplifying

$$(3) \quad \frac{r}{r'} = \frac{n}{n'}.$$

*The primitive radii are then proportionate to the numbers of teeth.*

**185. Calculation of the Primitive Radii.** In an *exterior gearing*, such as that which we have considered (Fig. 38), the distance between the centers of the two movers is equal to the sum of their primitive radii; that is to say, one should have

$$(4) \quad D = r + r',$$

$D$  representing this distance.

Let us take up again the proportion (3)

$$\frac{r}{r'} = \frac{n}{n'},$$

in which the radii  $r$  and  $r'$  are unknown quantities and the number of teeth  $n$  and  $n'$  known quantities.

Without changing the value of an equation, one can add to each of its members the same term, or an equivalent term. We can then write

$$\frac{r}{r'} + \frac{r'}{r'} = \frac{n}{n'} + \frac{n'}{n'},$$

since the two terms  $\frac{r'}{r'}$  and  $\frac{n'}{n'}$  are both equal to 1.

The common denominator permits us to write

$$\frac{r + r'}{r'} = \frac{n + n'}{n'}$$

and because of (4) one will also have

$$\frac{D}{r'} = \frac{n + n'}{n'},$$

from whence we deduce

$$(5) \quad r' = D \frac{n'}{n + n'}.$$

In an analogous manner we would find

$$(6) \quad r = D \frac{n}{n + n'}.$$



**186. Numerical Application.** A barrel of 80 teeth should gear in a pinion with 10 leaves, what should be the primitive radii of the two movers, knowing that the distance between their centers is 11.565 mm.?

Replacing in formulas (5) and (6) the letters by their values above given, one will have

$$r' = 11.565 \times \frac{10}{80 + 10} = \frac{11.565 \times 10}{90} = \frac{11.565}{9},$$

and

$$r = 11.565 \times \frac{80}{80 + 10} = \frac{11.565 \times 80}{90} = \frac{11.565 \times 8}{9}.$$

These two calculations give

$$\begin{aligned} r' &= 1.285 \text{ mm.} \\ r &= 10.28 \quad \text{"} \end{aligned}$$

As a verification, one should have

$$D = r + r' = 10.28 + 1.285 = 11.565.$$

**187.** To obtain the primitive radii, one can also simply regard the distance  $D$  as divided into as many parts as there are teeth in the wheel and the pinion together; therefore, into  $n + n'$  parts, and appropriate a number  $n$  of these parts as the radius of the wheel and a number  $n'$  for that of the pinion. The calculation is thus brought back to that of the preceding example.

**188.** The case of exterior gearing is the one which is most generally presented in practice. In this system we will observe that the movement of the two mobiles takes place in contrary directions; when the wheel is animated with a movement to the right, the pinion will possess a movement to the left.\*

**189.** When the center of rotation of the pinion is placed in the interior of the wheel's circumference (Fig. 44), the gearings thus constructed take the name

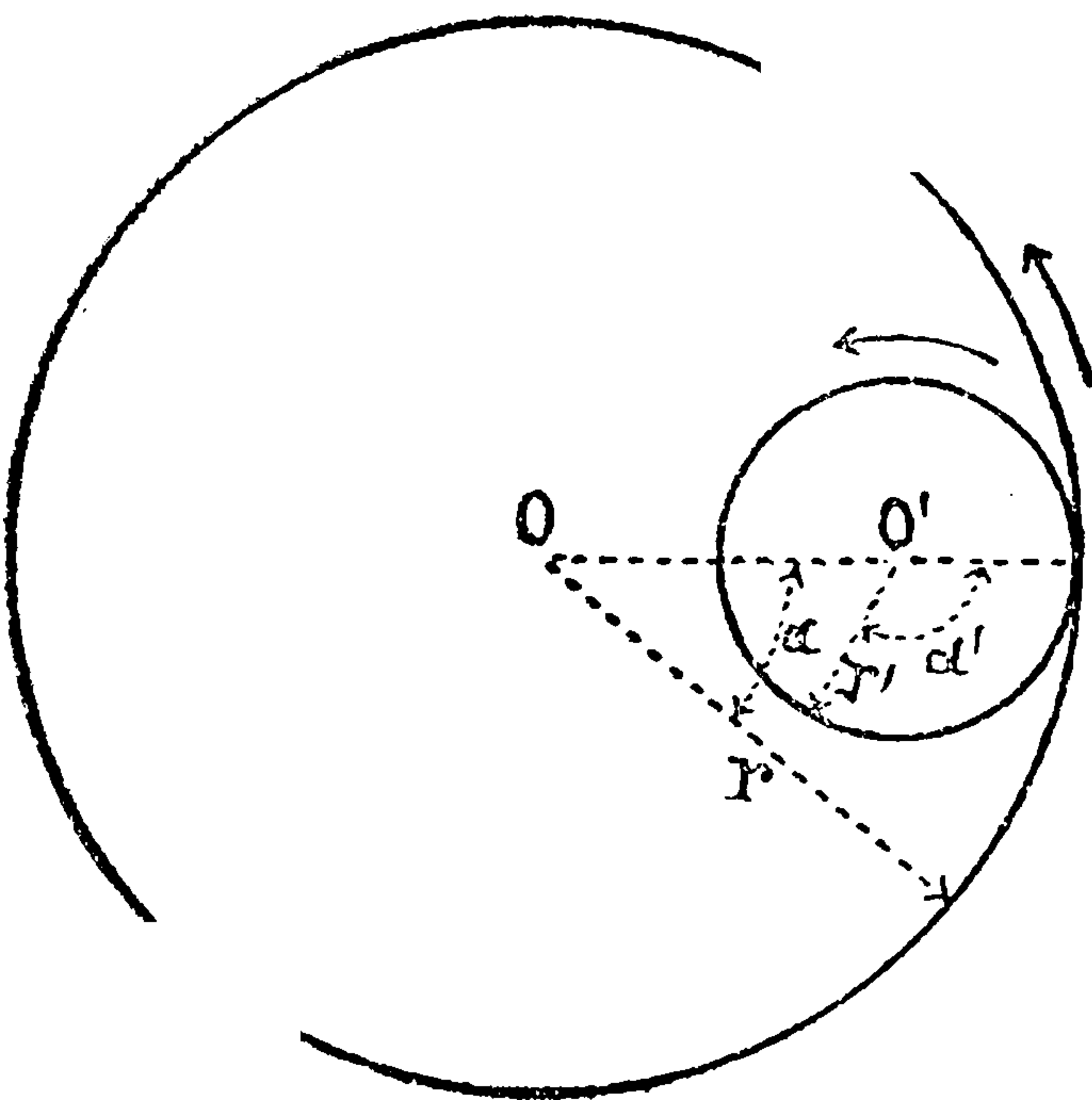

Fig. 44

\*It is customary to call "motion to the right" that which is effected in the same direction as that of the hands of a watch when looking at the dial.





**THIS PAGE IS LOCKED TO FREE MEMBERS**

Purchase full membership to immediately unlock this page



# HISTORY

Tens of thousands of important historical sources, many previously unobtainable, are now available for the first time with a Forgotten Books Full Membership.

Unlimited Access  
\$8.99/month

**Continue**

\*Fair usage policy applies



**191.** Let us now examine a kind of gearing sometimes employed and which is called rack gearing. In this case the primitive circumference of the wheel becomes a straight line; its radius is, consequently, infinite and the number of its teeth unlimited. This gearing can be considered either as exterior or as interior, for the distance between the centers can, equally, be

$$D = \infty + r' = \infty - r' = \infty.$$

To determine the primitive radius of the pinion gearing in the rack, it is sufficient for us to know the number of its teeth and the pitch of the gearing.

In Fig. 45 let  $a b$  equal the pitch of one of these gearings, and place

$$a b = A;$$

let us call  $n'$  the number of leaves which the pinion should have; the primitive circumference will then have for its value

$$2 \pi r' = A n',$$

which gives

$$(10) \quad r' = \frac{A n'}{2 \pi}.$$

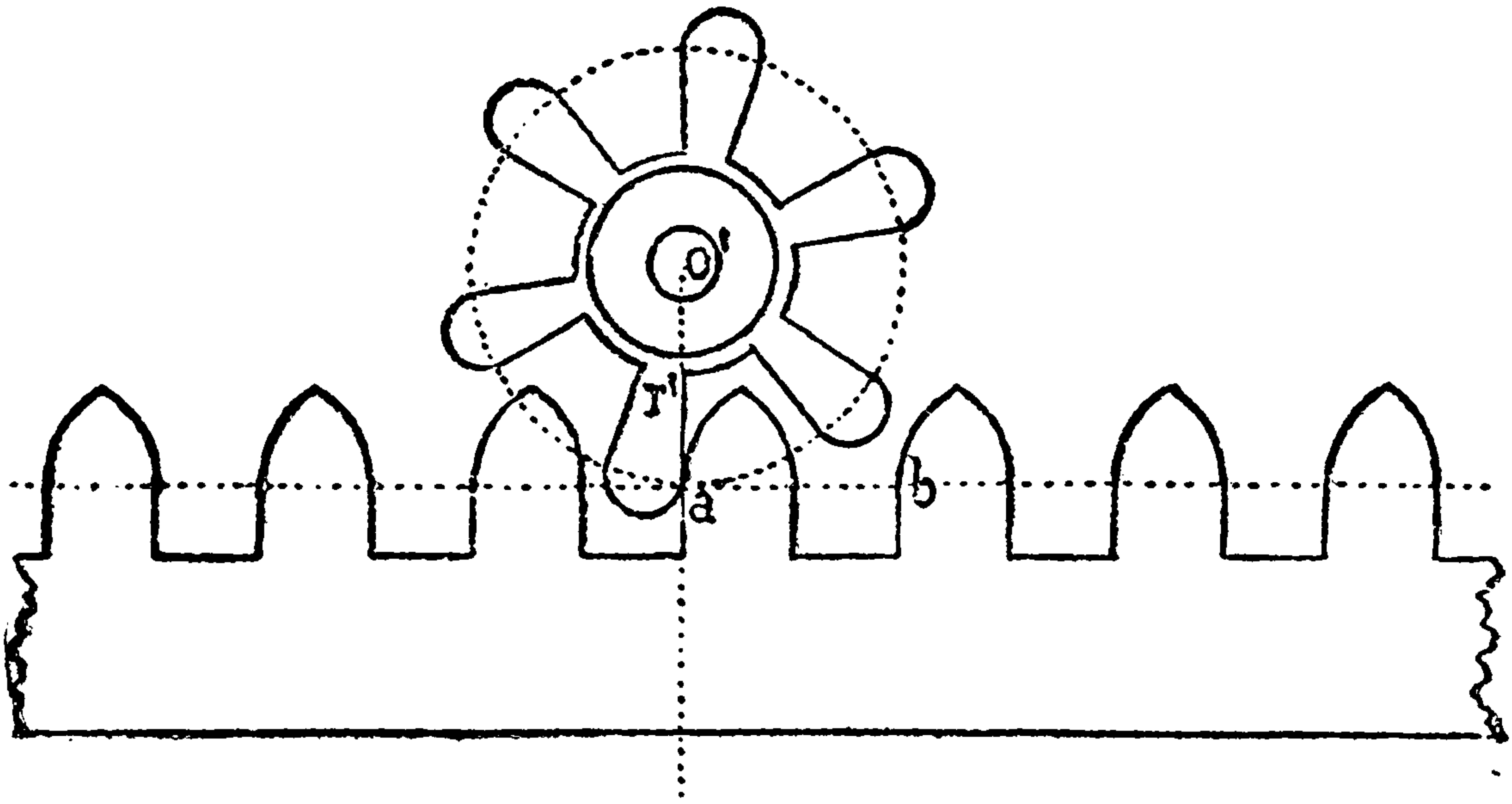

Fig. 45

**192.** Numerical example. Let 2.8 mm. be the pitch of a rack gearing, the pinion must have 12 leaves, what should be its primitive radius?

The formula (10) gives

$$r' = \frac{A n'}{2 \pi} = \frac{2.8 \times 12}{2 \times 3.1416} = \frac{2.8 \times 6}{3.1416} = 5.347 \text{ mm.}$$

The radius sought should then be

$$r' = 5.347 \text{ mm.}$$



**193. Application of the Theory of Primitive Radii to the Escapements.** The theory of gearings finds its application not only in the wheel-work, but also every time that there is a question of the transmission of movements of rotation around two fixed axes. It can then be applied also in special cases, such as one encounters in the study of the escapements, the mechanisms of repeaters, etc.

It sometimes happens, and especially in the last cases, that one knows the distance between the centers of rotation and the relation of the *angles* traversed in the same time by the movers considered, and that one may have to determine their primitive radii with the object of finding out the form of the surfaces in contact.

The formula (1) gives us the proportion

$$\frac{r}{r'} = \frac{\alpha'}{\alpha},$$

which indicates that the primitive radii are inversely proportionate to the angles traversed in any equal times.

Furthermore, one should have, when the rotations of the two movers take place in opposite directions,

$$D = r + r',$$

and when they take place in the same direction

$$D = r - r'.$$

On performing identical operations to those which we have indicated (185), one will arrive at the following results :

Exterior gearing,

and (11)  $r = D \frac{\alpha'}{\alpha + \alpha'}$

(12)  $r' = D \frac{\alpha}{\alpha + \alpha'}$

Interior gearing,

(13)  $r = D \frac{\alpha'}{\alpha - \alpha'}$

and

(14)  $r' = D \frac{\alpha}{\alpha - \alpha'}$

**194. Numerical Example.** To find the primitive radii of an escape wheel and of the anchor, knowing, that while the wheel traversed an angle of  $10^\circ = \alpha$ , the anchor turns an angle of  $9^\circ = \alpha'$ . Moreover, let the distance between the centers be  $D = 100$  mm.

Let us remark that, the wheel being animated with a movement to the right, the anchor possesses a movement to the left,



when the tooth acts on the exit pallet, and a movement to the right when it acts on the entrance pallet. The first case is, then, that of an exterior gearing, while the second is similar to that of an interior gearing.

The formulas (11) and (12) will give us

$$r = D \frac{a'}{a + a'} = 100 \frac{9}{10 + 9} = 100 \frac{9}{19} = 47\frac{7}{19}$$

and

$$r' = D \frac{a}{a + a'} = 100 \frac{10}{10 + 9} = 100 \frac{10}{19} = 52\frac{12}{19}$$

The formulas (13) and (14) will then give us

$$r = D \frac{a'}{a - a'} = 100 \frac{9}{10 - 9} = 100 \times 9 = 900$$

and

$$r' = D \frac{a}{a - a'} = 100 \frac{10}{10 - 9} = 1000.$$

#### Second—Form of the Teeth and Leaves.

##### 195. General Study of the Transmission of Force in Gearings.

In the chapter on motive forces, we compared the energy displayed by a motive spring to the effect produced by a weight placed at the extremity of a lever arm equal to the unit of distance, the system being in equilibrium (83).

This fictitious weight  $F$  represents the *moment of the force* with relation to the axis around which this force exerts its action.

By means of the gearing, this action is transmitted to the second axis and the problem is to find the moment  $F'$  of a force which, with relation to the second axis, would be in equilibrium with the moment  $F$

196. Let us suppose at first that the point of contact of the tooth of the wheel with the pinion leaf is found on the line of centers (Fig. 46), and regard the wheel  $O$  as a lever in the state of equilibrium. This system fulfills in effect all the conditions relative to the lever ; the fulcrum is  $O$ , the power is  $F$ ; the resistance is that which arises from the wheel  $O'$  and the moment of which we have to find.

This resistance is applied at the point of contact,  $c$ , of the wheel-tooth and the pinion-leaf ; it is directed *normally* to the surfaces in contact ; here, perpendicularly to the line of centers and consequently following  $cN$ . It acts thus in a contrary direction to the force  $F$ .





**THIS PAGE IS LOCKED TO FREE MEMBERS**

Purchase full membership to immediately unlock this page

# DELVE INTO FANTASY, MAGIC, MYTHOLOGY & FOLKLORE

Forgotten Books'  
Full Membership gives  
access to 797,885 ancient  
and modern, fiction and  
non-fiction books.

**Continue**

\*Fair usage policy applies



from whence one finds the value sought

$$(18) \quad F' = F \frac{r'}{r}.$$

On account of the proportion (3) :

$$\frac{r}{r'} = \frac{n}{n'},$$

one can then write

$$(19) \quad F' = F \frac{n'}{n}.$$

**196 a.** If, for example, the moment of  $F$  is equal to 4000 gr., the number of teeth in the wheel  $n = 80$  teeth and the number of leaves in the pinion  $n' = 10$  leaves, the formula (19) would become

$$F' = 4000 \frac{10}{80} = 500 \text{ gr.}$$

A weight of 500 gr. suspended at the extremity of a lever arm 1 mm. from the center of the pinion would then make equilibrium with a weight of 4000 suspended at the same distance from the center of the wheel.

Let us remark at this time that if the force has diminished during its transmission, and is not more, with relation to the pinion, than the eighth part of what it was with relation to the wheel, the speed of the last mover is, on the other hand, increased and has become eight times greater.

**197.** Supposing that the preceding calculation relates to the gearing of a barrel with the center pinion, let us now seek for the moment  $F''$  of the force that should be applied to the third wheel to make equilibrium with the moment of the force of the barrel spring.

We have seen, in the preceding case, that on multiplying the moment  $F$  by the relation  $\frac{n'}{n}$ , one obtains the moment of the force applied to the center wheel ; on multiplying, then, this latter value by the relation  $\frac{n''}{n_1}$ , of the number of leaves in the third wheel pinion to the number of teeth in the center wheel, one will obtain the value sought, thus :

$$(20) \quad F'' = F \frac{n' n''}{n n_1}.$$

**198.** One could continue this reasoning for any number of wheels. Thus, the moment  $F''''$  that should be applied to the escape wheel to make equilibrium with the moment of the force of the spring, will be expressed by

$$(21) \quad F'''' = F \frac{n' n'' n''' n''''}{n n_1 n_2 n_3}.$$



199. Let us choose as numerical example the very frequent case,

$$F''' = 4000 \frac{10 \times 10 \times 10 \times 7}{80 \times 80 \times 75 \times 70} = \frac{5}{6} \text{ gr.}$$

The force has become 4800 times weaker but the speed of the last mover is 4800 times greater. That which, in mechanics, is lost in force is gained in speed and reciprocally.

200. We have just studied the transmission of the moment of the force from one wheel to another, admitting that the point of contact of the movers is on the line of centers.

Let us now see under what condition this point of contact can be found outside of that line, in such a manner that the *moment of*

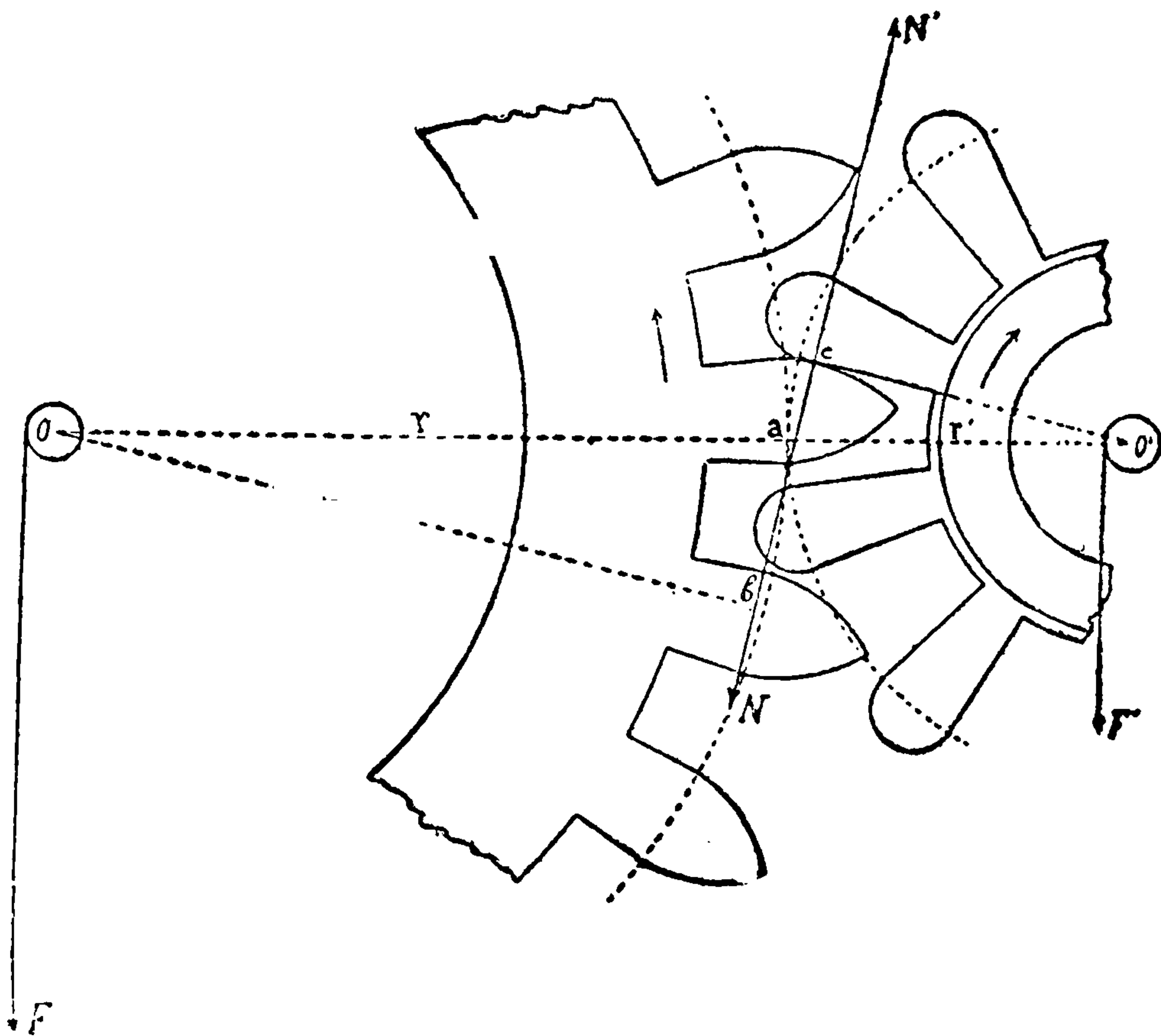

Fig. 47

*force transmitted preserves at each instant the same value that it possessed when the contact took place on the line of centers.*

Otherwise expressed, the question is to form the teeth and the leaves in such a manner that the transmission of the force may be constant. It is necessary, therefore, that the value given by the formula (19)

$$F' = F \frac{n'}{n}$$

remains the same no matter what the position of the movement.



**201.** Let us suppose that the wheel-tooth and the pinion-leaf are formed in such a manner that at one instant of movement this contact is found at the point  $c$  (Fig. 47), situated outside of the line of centers. Let us find, in this position, what would be the value of the weight  $F'$  which would make equilibrium with the weight  $F$ , these two forces being placed at the unit of distance from the axes.

The normal to the point  $c$  along which is exercised the reciprocal action of the tooth on the leaf and the leaf on the tooth, is necessarily normal both to the curve of the tooth and to the form of the leaf, since these two lines are tangent at this point; it is directed along the straight line  $NN'$ .

As in the preceding case, the two wheels can be compared to levers. The wheel  $O$  is, in effect, acted upon by two forces. The one,  $F$ , tending to impart to it a movement to the left; its normal is  $F \times 1$ , therefore,  $F$ ; the other,  $N$ , directed in the opposite direction and arising from the pinion leaf, its lever arm being the perpendicular  $O b$ , its moment is

$$N \times O b.$$

Because of the equilibrium, one will have (43)

$$(22) \quad F = N \times O b.$$

The pinion is likewise acted upon by two forces: the one,  $F'$ , whose moment is  $F'$ ; the other, arising from the pressure that the tooth exerts on the leaf at the point  $c$ , following the normal direction  $c N'$ ; its moment is

$$N' \times O' b'.$$

Since the direction of this last force is inverse to that of  $F'$ , the equilibrium is produced by the equality of the moments:

$$(23) \quad F' = N' \times O' b'.$$

Dividing equation (22) by (23), one has

$$\frac{F}{F'} = \frac{N O b}{N' O' b'}$$

Since equilibrium exists in the system, the forces  $N$  and  $N'$ , which have the same alignment must be equal; in consequence, one has, after simplifying,

$$\frac{F}{F'} = \frac{O b}{O' b'}.$$





**THIS PAGE IS LOCKED TO FREE MEMBERS**

Purchase full membership to immediately unlock this page

# HISTORY

Tens of thousands of important historical sources, many previously unobtainable, are now available for the first time with a Forgotten Books Full Membership.

Unlimited Access  
\$8.99/month

**Continue**

\*Fair usage policy applies





If the normal cuts the line  $O O'$  at the point  $O'$ , the radius  $r'$  becomes nothing and one has

$$F' = F \frac{0}{r} = 0;$$

the transmission of the movement of the force is impossible.

If, on the contrary, the normal cuts the line  $O O'$  at the point  $O$ , one has in this case  $r = 0$  and consequently :

$$F' = F \frac{r'}{0} = \infty;$$

the force  $F'$  becomes infinitely great, but the transmission of the movement is wholly impossible, since the primitive radius of the wheel is annulled.

If, finally, the normal was parallel to the line  $O O'$ , one would then have

$$F' = F \frac{\infty}{\infty} = F.$$

This could be the case with the entrance pallet of the anchor escapement if the escape wheel should traverse the same angle  $\alpha$  as the anchor which it drives ; one has thus (193) :

$$r = D \frac{\alpha}{\alpha - \alpha} = r' D \frac{\alpha}{\alpha - \alpha} = D \frac{\alpha}{0} = \infty;$$

the primitive radii are then infinite.

**206.** The law which we have formulated (203) shows us, even from the beginning, that the problem whose object is to find the curves of the teeth and leaves is susceptible of a great variety of solutions, for one may give to the teeth of one of the wheels any special form and find such a curve for the teeth of another wheel as should satisfy it, in its successive contacts with the first, according to the conditions given. However, the laws of the resistance of the materials, the wear of the rubbing surfaces, the inflexions of the curves, are so many causes which make us, in practice, reject the use of a number of these solutions.

**207.** Let us further remark that the formula  $F' = F \frac{n'}{n}$  is independent of the absolute value of the primitive radii  $r$  and  $r'$  and depends, consequently, only on the relation of their primitive circumferences.

#### **Determination of the Forms of Contact in Gearings.**

**208.** There are several methods serving to determine the bearing surfaces of teeth and leaves ; the basis of these different constructions rests generally on the law which we have set forth (203). We will study here three of the principal of these.



209. First—Graphic Method. Exterior Gearing. The fundamental condition, that the common normal to the point of contact of two forms which drive each other should invariably pass through

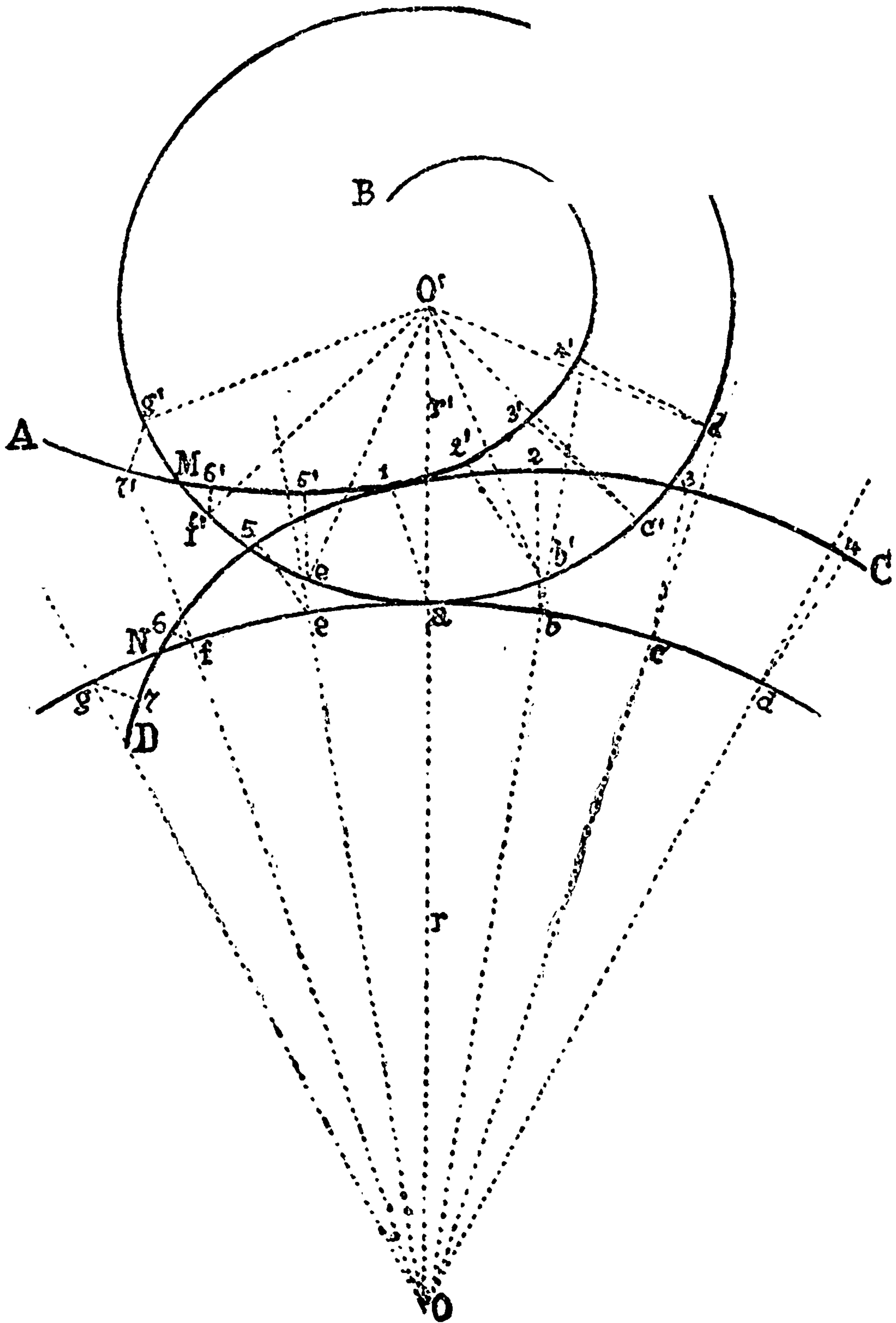

Fig. 48

the point of tangency of the primitive circumferences, furnishes an easy graphical means to determine one of the curves, when the other is given.

Let  $O$  and  $O'$  (Fig. 48) be the primitive circumferences of a gearing and  $AB$  the given curve of the pinion in any position.



If from the point of tangency  $a$  we draw a normal to this curve, we will thus have the point of contact  $\mathbf{1}$  of the leaf of the pinion and the tooth of the wheel corresponding to the position described.

Let us remark that, in this position, the normal  $a \mathbf{1}$  forms the same angle with the radius  $r'$  of the pinion as it does with the prolongation of the radius  $r$  of the wheel, since these two lines run into each other.

Let us afterwards mark on each of the primitive circumferences a point,  $b$  and  $b'$ , determined in such a manner that one may have

$$\text{arc } a b = \text{arc } a b'.$$

Through the points  $b$  and  $b'$  draw the radii  $O b$  and  $O' b'$ , prolonging the first sufficiently beyond the circumference of the wheel; from the point  $b'$  trace the normal to the curve  $b' z'$ , then lay off from the point  $b$  as summit, an angle equal to  $z' b' O'$  and mark the point  $z$  making  $b z$  equal to  $b' z'$ . The point  $z$  belongs to the curve sought, for if the points  $b$  and  $b'$  arrive at the position  $a$ , the radii  $O' b'$  and  $O b$  will have the same alignment and the points  $z$  and  $z'$  the same position.

One can thus determine as many points as one wishes, and, on connecting them by a continuous curve, one will obtain a form such as  $D C$ , possessing the ability to drive the curve  $A B$  in such a manner that the transmission of the movement may be uniform.

If one conducts the curve  $A B$  in such a way that the point  $M$ , which belongs both to this curve and to the primitive circumference of the pinion, presents itself at the place of the point  $a$ , the point  $N$ , which belongs to the curve sought and to the primitive circumference of the wheel, should enter into contact with the point  $M$

Thence it follows that one has

$$\text{arc } a M = \text{arc } a N,$$

and also that when the contact takes place on the line of centers it is found at the point of tangency of the primitive circumferences.

**210. Interior Gearings.** For an interior gearing, one determines the curve of contact in the same manner as for an exterior gearing.

One describes the primitive circumferences  $O$  and  $O'$  tangent to the point  $a$  (Fig. 49) and the curve given  $A B$ , which we will suppose anew to be that of the pinion. On drawing from the point  $a$





**THIS PAGE IS LOCKED TO FREE MEMBERS**

Purchase full membership to immediately unlock this page

# DELVE INTO FANTASY, MAGIC, MYTHOLOGY & FOLKLORE

Forgotten Books'  
Full Membership gives  
access to 797,885 ancient  
and modern, fiction and  
non-fiction books.

**Continue**

\*Fair usage policy applies



solutions ; let us remark, however, that a number among them present inconveniences, and even impossibilities, for practical execution.

**211. Second—Method of the Envelopes.** The centers of rotation of the two wheels are habitually fixed and the mobiles turn around these points.

Let us suppose, however, that a movement of rotation may have been imparted to the whole system around one of the centers, that of the wheel, for example, and that this movement is executed in such a manner that its angular speed may be equal to, but in a contrary direction to the angular speed animating the wheel *O*. It is evident that from this method the wheel remains in a state of repose and that the working of this gearing will remain the same as if the two centers were fixed and the two wheels turned simply around their respective centers.

The gearing of the fourth wheel with the escape pinion in timepieces called “*tourbillon*” offers an example of such a movement. The wheel is screwed on to the plate of the watch ; its movement is, therefore, null with relation to this plate. The escape pinion, pivoted in a mobile cage, turns around its center and simultaneously with the cage, whose center of rotation is also the center of the fourth wheel.

The principle of the method of the envelopes rests on this sort of movement.

Let us adopt, in short, any form of leaf ; on representing the pinion in several successive positions of its movement, around the wheel, we will obtain the form of the tooth, on joining by a tangent curve the positions that the leaf will occupy during this movement.

One can then say that the tooth is the “envelope” of the different positions occupied successively by the leaf during the movement of the pinion around the center of the wheel. With this method, this tooth remains constantly in contact with the leaf, and the transmission of the force will be effected without loss. The movement of the wheel being uniform, that of the pinion will consequently also become so.

Let us take some examples :

**212.** The transverse section of the pinion leaf of a *lantern gearing* is a circle whose center is situated on the primitive circumference. Suppose we wish to determine the form of the tooth.



If (Fig. 50) the circumference passing through the points  $o, 1'', 2'', 3'', \dots$  is the primitive circumference of the wheel,

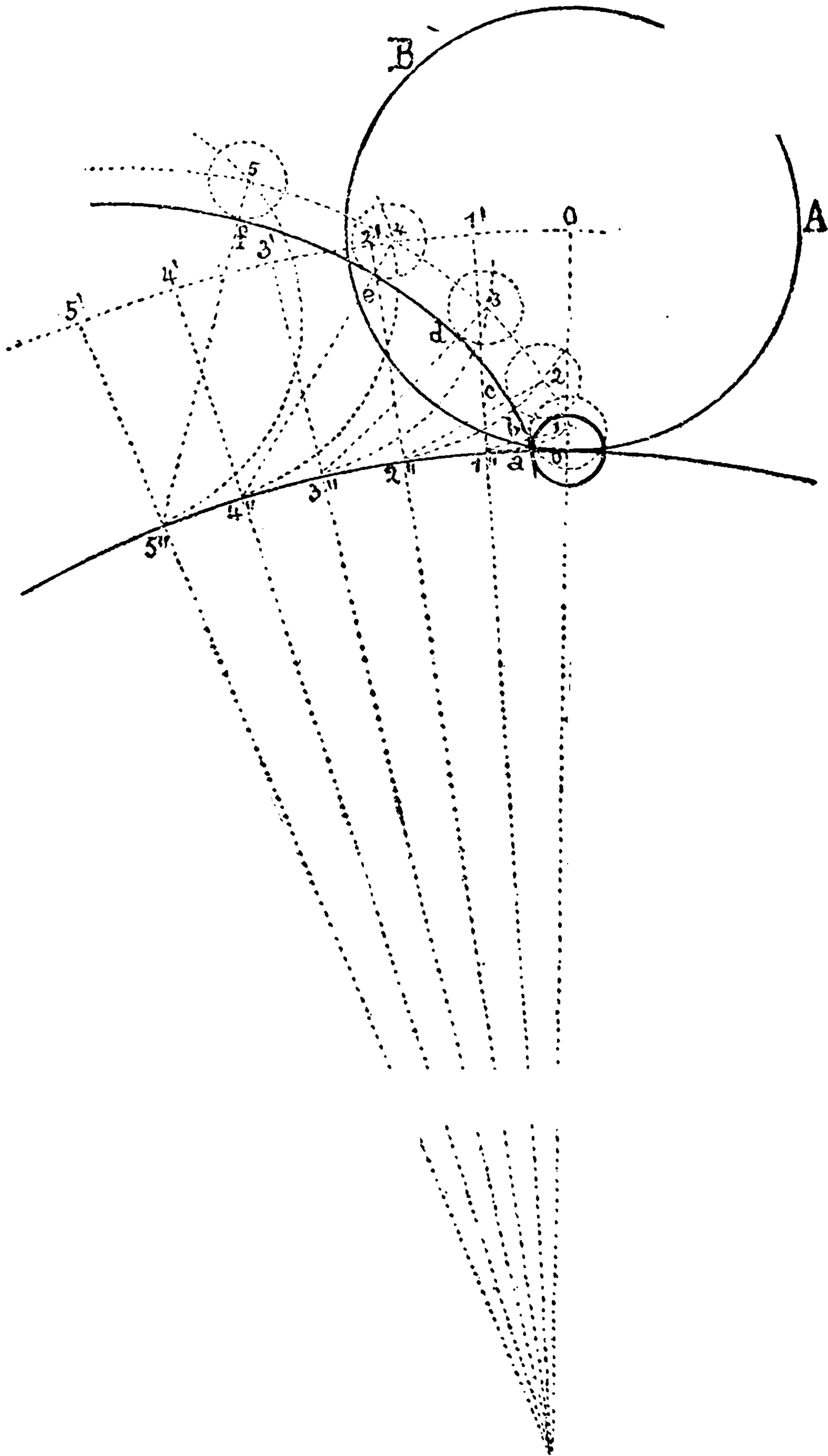

Fig. 50

and  $O' A B$  that of the pinion, and if this last is moved without slipping, around the primitive circumference of the wheel, the



successive centers of the pinion will occupy in turn the points  $o', 1', 2', 3', \dots$ . On conceiving, then, the corresponding positions of the pinion leaf whose centers should occupy the positions  $o, 1, 2, 3, \dots$ , and on drawing the curve  $a b c d, \dots$  tangent to

the leaf in these several positions, one will obtain the curve of the tooth sought.

One sees that, if the pinion leaf is reduced to a point, the form of the tooth would be an "epicycloid" whose generating circle would be the primitive circle of the pinion. If the leaf is formed by a cylindrical pin, the curve for the tooth which *results* from it is parallel to this epicycloid, and is found removed a distance, equal to the radius of the pin.

One could draw a second curve tangent exteriorly to the several positions that the pin occupies during the movement; the curve thus formed would then drive the pin by its concavity.

The straight lines  $1'' 1, 2'' 2, \dots$  which connect the points of tangency of the primitive circles with the point describing the epicycloid are normal to the curve at these points.

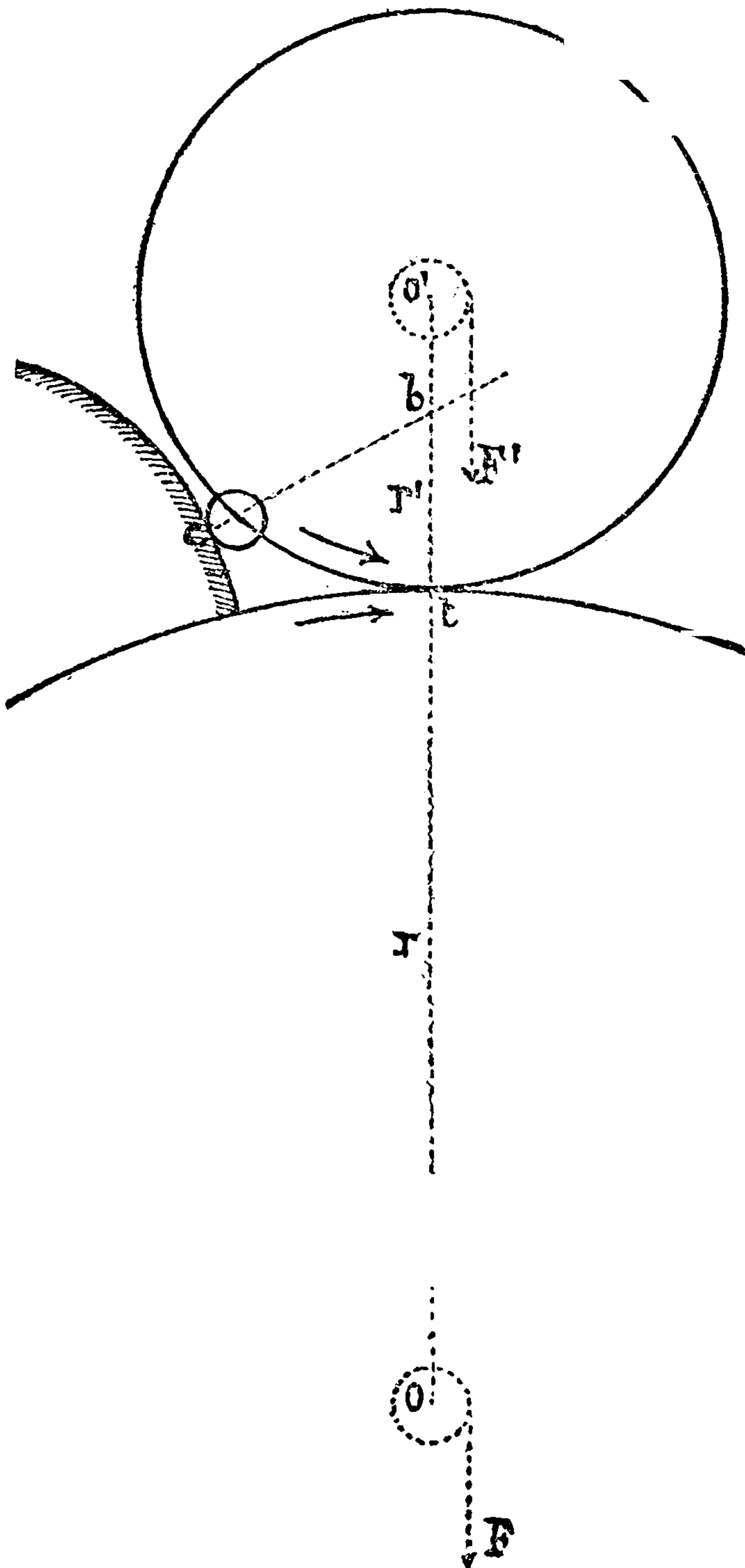

Fig. 51

**213.** Fig. 51 shows that if the contact of the tooth with the leaf took place at a point such as  $c$ , before the passage of the line of centers, there would be produced an abutting which, if it did not absolutely prevent transmission of the movement, would, however, modify considerably the uniform transmission of the force.





**THIS PAGE IS LOCKED TO FREE MEMBERS**

Purchase full membership to immediately unlock this page

# HISTORY

Tens of thousands of important historical sources, many previously unobtainable, are now available for the first time with a Forgotten Books Full Membership.

Unlimited Access  
\$8.99/month

**Continue**

\*Fair usage policy applies





to the movement indicated by the arrow, and the gearing would become, on that account, "interior."

**214.** Lantern gearing can be interior and then admits of two arrangements, according as the interior wheel or pinion carries the pins and the other the teeth, or as the large wheel carries the pins and the pinion the teeth.

**215.** Take, again, as a second example of the application of this construction, the straight line  $AB$ , given as the form of the pinion leaf, and let it be required to determine the curve of the wheel tooth (Fig. 53).

During the movement of the primitive circumference of the pinion around that of the wheel, the line  $AB$  will occupy successively the positions  $A'B'$ ,  $A''B''$ ,  $A'''B'''$ , etc. From the points of tangency, 1, 2, 3, 4, etc., let us draw respectively the perpendiculars to these lines and through the points  $a$ ,  $b$ ,  $c$ ,  $d$ , thus obtained, let us make a curve pass tangent to the successive positions of the line  $AB$ ; we will thus obtain the form of the tooth.

Let us remark that if the wheel is animated with a movement to the right, the position  $A''''B''''$  can become impossible for the transmission of the movement, for the reason that the wheel could then turn without driving the pinion. This shows us, moreover, that there exist limits beyond which the driving of the pinion by the wheel becomes practically impossible.

**216.** When the line  $AB$  passes through the center of the pinion, the curve of the tooth is an epicycloid produced by a point of a circle whose radius is equal to half that of the primitive circle of the pinion.

**217. NOTE.**—On comparing the two methods of determining the forms of contact which we have just examined, one can prove that the graphical method (209) is necessarily analogous to that of the envelopes. In short, in order to obtain the form of the tooth, we make one of the primitive circles with the given form roll around the other; the curve sought is, therefore, in both cases, that which passes through the meeting point of the normals with the given curve, in each of its successive positions. The reason which has made us separate these two parts of the same whole is simply the greater clearness in the explanation of the subject.

**218.** Let us take, for a last example, *gearings formed by the evolvent of a circle.*



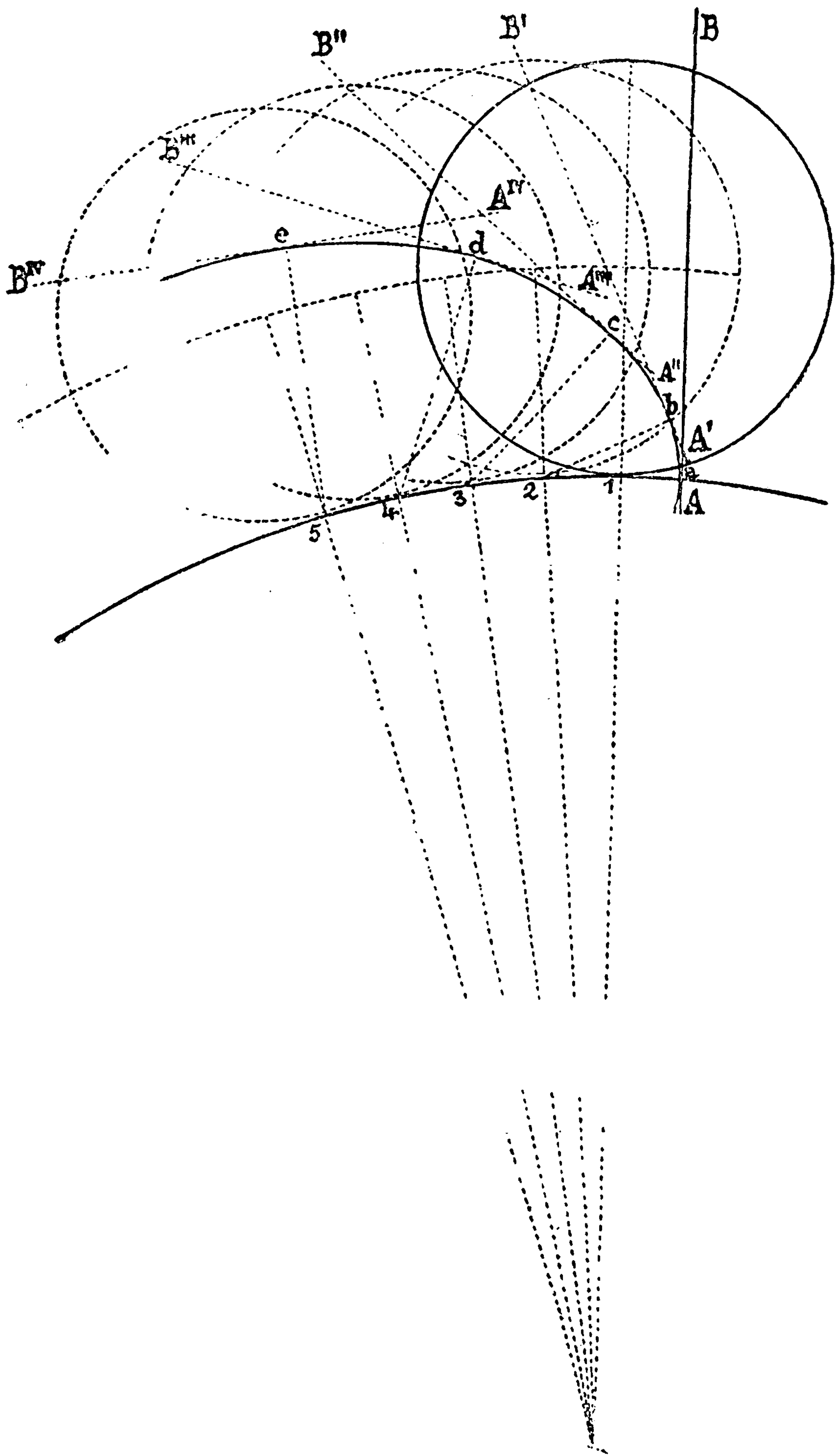

Fig. 53



The "evolvent" of a curve is another curve, such as  $C C' C'' C''' \dots$  produced by a point of a tangent to the first curve, whose contact changes continually, in such a manner that

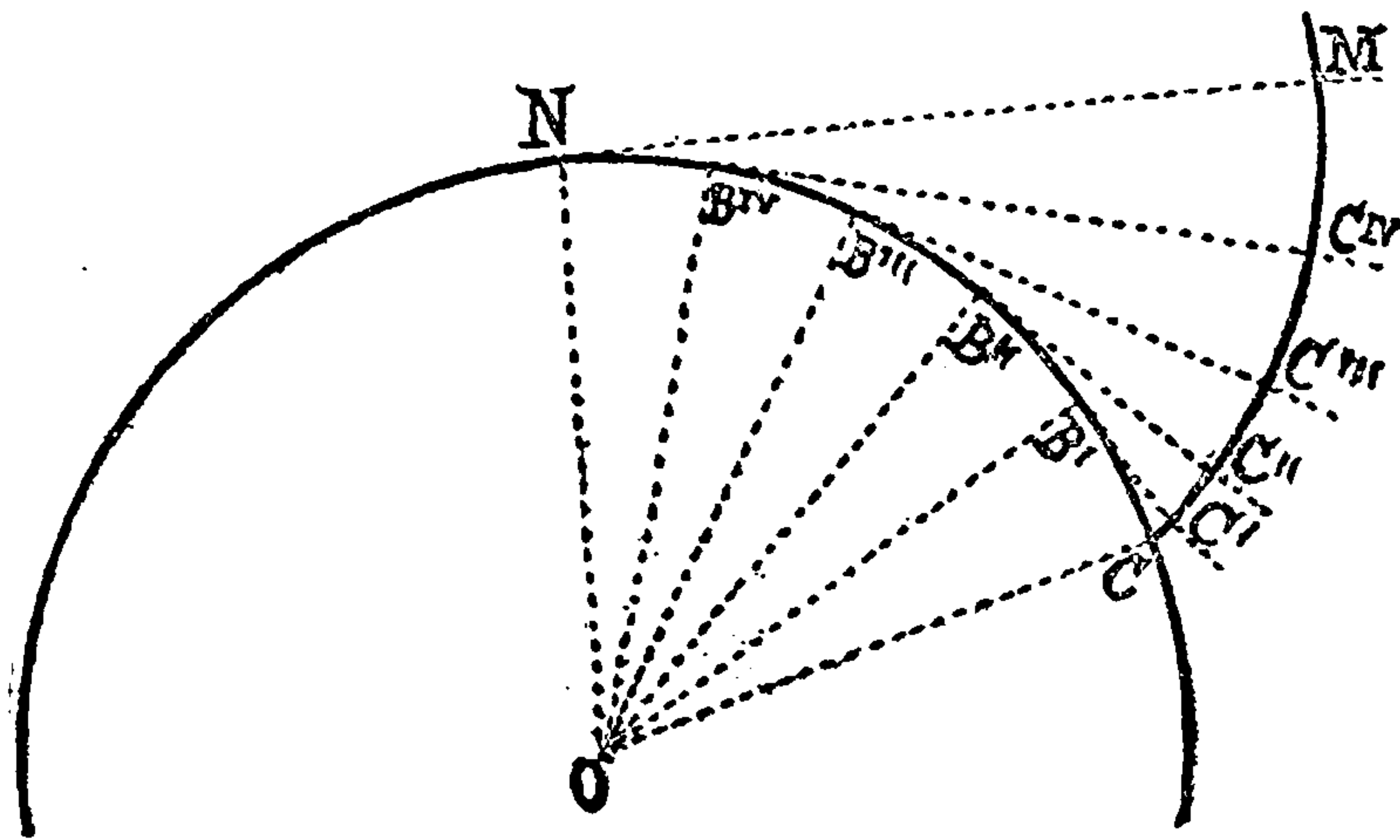

Fig. 54

the distance of the describing point from the point of contact may be constantly equal to the space traversed by the point of contact on the curve. Thus (Fig. 54),  $B' C'$ ,  $B'' C''$ ,  $\dots$  being positions of the tangent, one should have  $B' C' = B' C$ ;  $B'' C'' =$

$B'' C$ , etc. The curve  $C B' B'' \dots$  on which the tangent rolls is the "evolvent" of  $C C' C'' \dots$

The point  $C$  where the evolvent meets its evolvent is the *origin*.

219. For gearing formed by the *evolvent of a circle*, one adopts for the motive tooth the evolvent of any circle concentric and interior to the primitive circle of one of the two wheels. The profile of the corresponding tooth for the other wheel will be determined, then, in a very simple manner.

Let the evolvent  $D' D'$  of the circle  $E' E'$  (Fig. 55) be given. In order to determine the point of contact  $M$  of this curve and of the form sought, draw the normal  $A A'$  from the point of tangency of the primitive circumferences; by the construction this normal is at the same time tangent to the "evolvent" circle  $E' E'$ . But if from the centers  $O$  and  $O'$  we draw the perpendiculars  $O B$  and  $O' B'$  on this normal, we will obtain two similar triangles whose homologous sides are in the same relation. But the sides  $a O$ ,  $a O'$  and  $O' B'$  are constant, being the radii of invariable circles; therefore,  $O B$  must be also constant. Consequently, the normal  $A A'$  of the curve  $D D$  sought remains always at the same distance from the center  $O$  and it, therefore, envelopes a circle  $E E$  concentric and interior to the primitive circle of the wheel and whose radius is found with that of  $E' E'$  in the same relation as those of the primitive circles themselves. *The form of the tooth is, therefore, another evolvent of a circle.*

The point of contact being found at any instant on the line  $A A'$ , this line is the geometrical place.





**THIS PAGE IS LOCKED TO FREE MEMBERS**

Purchase full membership to immediately unlock this page

# DELVE INTO FANTASY, MAGIC, MYTHOLOGY & FOLKLORE

Forgotten Books'  
Full Membership gives  
access to 797,885 ancient  
and modern, fiction and  
non-fiction books.

**Continue**

\*Fair usage policy applies



Thus, in gearings of this kind the place of the points of contact is the common tangent to both circles of construction.

The common normal retains, therefore, a fixed position in space during the movement of the two wheels around their respective centers.

This right line can make any angle with the line of centers ; it is the general custom, however, to place them at  $75^\circ$  from each other.

The especial advantages of this system of gearings are, first, that the two wheels being similar and the teeth not showing any change of curvature at the passage of the line of centers, any one tooth will drive the other before as well as after the line of centers. Moreover, the construction of a wheel not depending in any way on that which it should drive, all wheels evolvents of circles can gear together ; the relation of the velocities which they have is only to be considered. This is a valuable property which allows a single motive wheel to drive at once several others, or to make several wheels gear together successively, as is the case in the screw-cutting lathe. Another advantage to be considered is that the distance of the centers can vary between certain limits without the regularity of the gearing suffering in consequence.

The gearing of evolvents can be interior ; the form of the teeth, in place of being convex, is then concave. This fact is an inconvenience which makes this combination little used. One can, in these cases, diminish the concavity by multiplying sufficiently the number of teeth.

**220. Third—Roller Method.** The principle of this method differs from the preceding, but is just as general.

Let us imagine, first, any polygon,  $AB C D E F G$  (Fig. 56), compelled to roll without sliding the length of a line  $X Y$ . At a

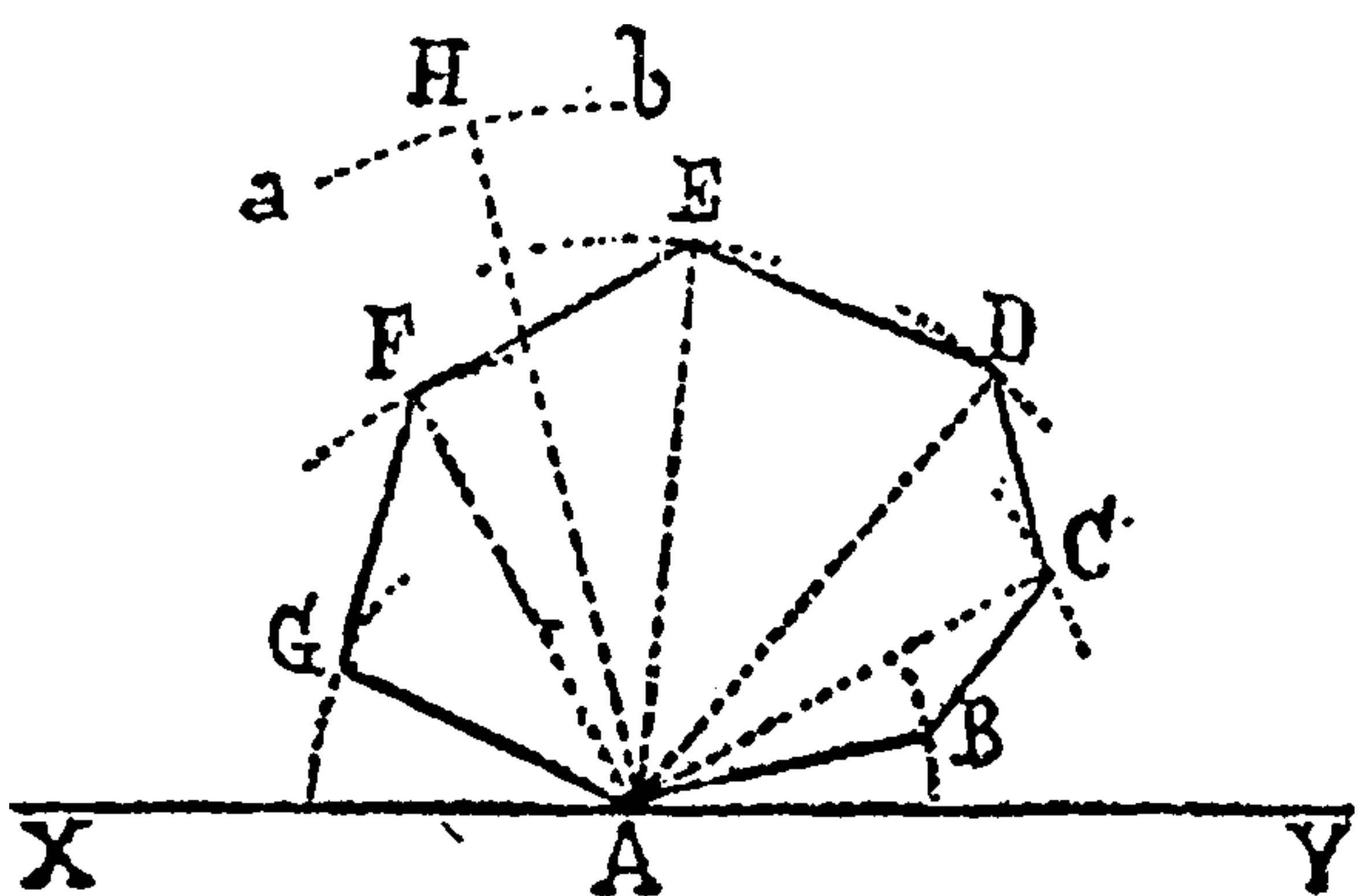

Fig. 56

certain moment of the movement one of the angles,  $A$ , for example, is found in contact with the line  $X Y$ . During the rolling around this point all the points of the polygon, and with them all those which, interiorly or exteriorly, could be unalterably connected with them, describe arcs of circles around the



center  $A$ . As, for example, the point  $H$ , exterior to the polygon but unalterably connected with it, will describe an arc  $a b$  during the instant of the rolling considered.

The radii of these diverse arcs of circles will be their normals and will necessarily pass through the point  $A$ .

Let us remark that the length of each arc described depends on that of its radius and on the number of sides that compose the polygon. If we suppose this geometrical figure formed with a great number of sides, the lengths of

the arcs described while it turns around one of its sides, will diminish. At the limit, that is to say, when the number of sides becomes infinite, the polygon is confounded with a continuous curved line, and each of the points which compose it will describe, nevertheless, as the polygon rolls around an instantaneous point of contact, an infinitely short arc of a circle. But, however small it may be, this arc possesses, nevertheless, two extreme radii, drawn infinitely near to each other and passing through the instantaneous *center of rotation*. Since they are drawn infinitely near to each other, either

of these radii of curvature is, consequently, normal to the point considered of the total curve described by this point during the continual rolling of the generatrix along the line of the *directrix*.

This established, let there be, moreover (Fig. 57), any curve,  $a b c$ , which we cause to roll on the exterior of the primitive circumference of a wheel and at the interior of that of the pinion. If, to be more clear, we suppose that a point  $H$  taken outside of this curve may be connected with it in an invariable manner, the movement of this point will be similar to that of all the points composing the given curve.

During a certain period of the curve's movement at the exterior of the primitive circle of the wheel  $O$ , this point  $H$  will

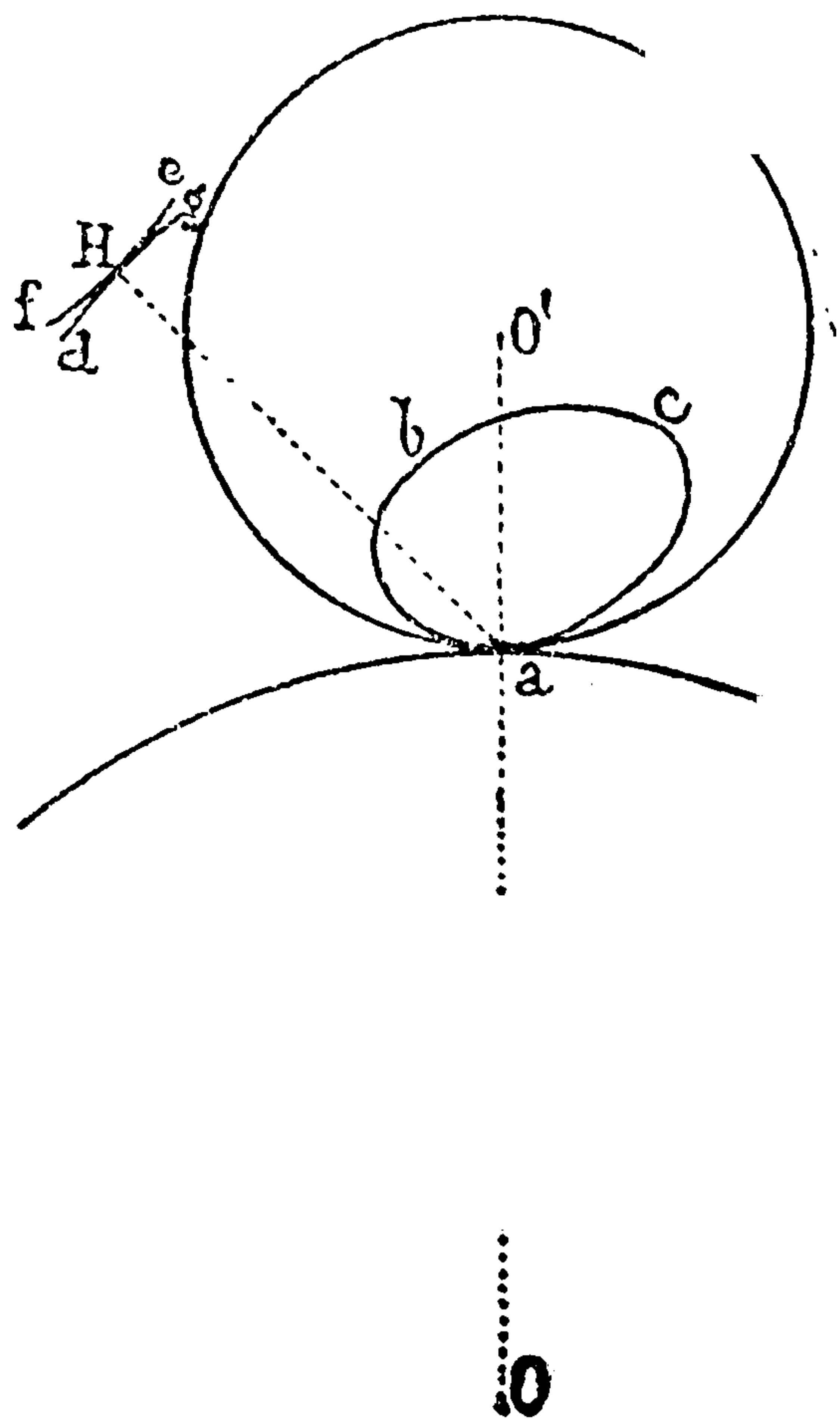

Fig. 57



describe a trajectory  $d H g$ ; then, when the movement takes place at the interior of the primitive circle of the pinion  $O'$ , its trajectory will be the line  $f H e$ . These two curves can be adopted as the profile of conjugate teeth. In fact, we imagine that the curve  $a b c$  follows the movement of the two primitive circumferences in such a manner that these three curves remain constantly tangent at  $a$ .

The trajectories meet at  $H$ , since this point describes them both; moreover, they are tangent there, since the normal for each is obtained on joining the describing point  $H$  to the point of contact  $a$  of the moving curve  $a b c$  with both of the primitive circumferences established.

Consequently, the common normal of the teeth, at their point of contact, passes through the point of tangency of the primitive circumferences, and the verification of this fact suffices, we know, in order to have the curves obtained, adopted as forms of teeth.

Let us examine from this point of view the following case :

**221. Flank Gearings.** In order to obtain a profile very much used in the practice of horology, one chooses as the generating form the circumference whose

diameter is the radius of one of the primitive circles and one takes the describing point on its circumference (Fig. 58).

In the movement of the generating circle around the primitive circle of the wheel, the point  $A$  describes an arc of an "epicycloid"  $A D$ .

In its movement in the interior of the primitive circle of the pinion, this same point  $A$  describes a straight line  $O' A$ , which is a radius of the circle  $O'$ . This plane surface  $O' A$  is called a "*flank*."

Let us remark that the epicycloid which forms the profile of the tooth in flank gearings is not the same as that which we have

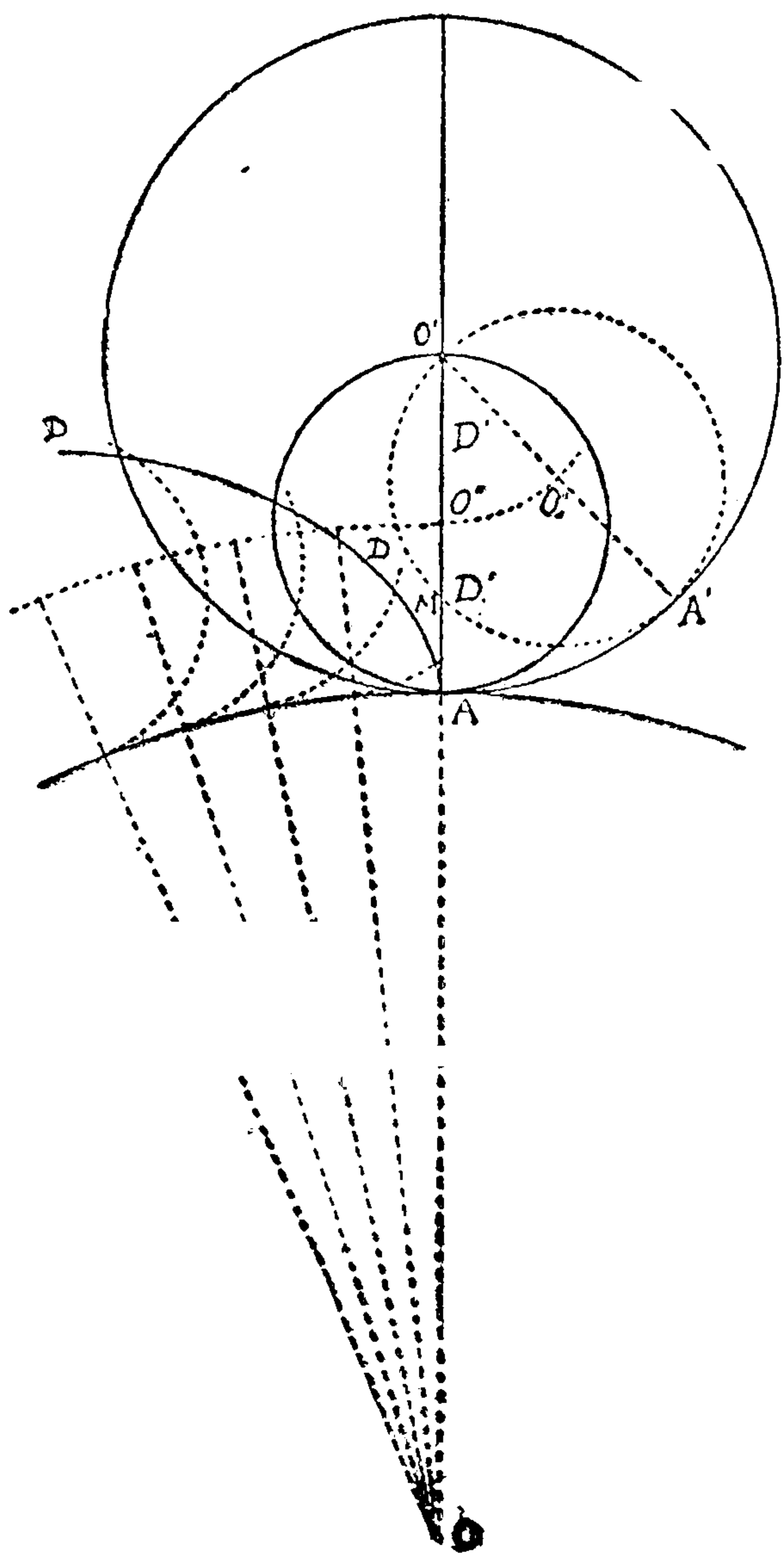

Fig. 58





**THIS PAGE IS LOCKED TO FREE MEMBERS**

Purchase full membership to immediately unlock this page



# HISTORY

Tens of thousands of important historical sources, many previously unobtainable, are now available for the first time with a Forgotten Books Full Membership.

Unlimited Access  
\$8.99/month

**Continue**

\*Fair usage policy applies



225. In order that the contact of two similar teeth may commence before the line of centers and end on the other side of that line, it suffices if each tooth has a *mixed* profile formed with a flank interior

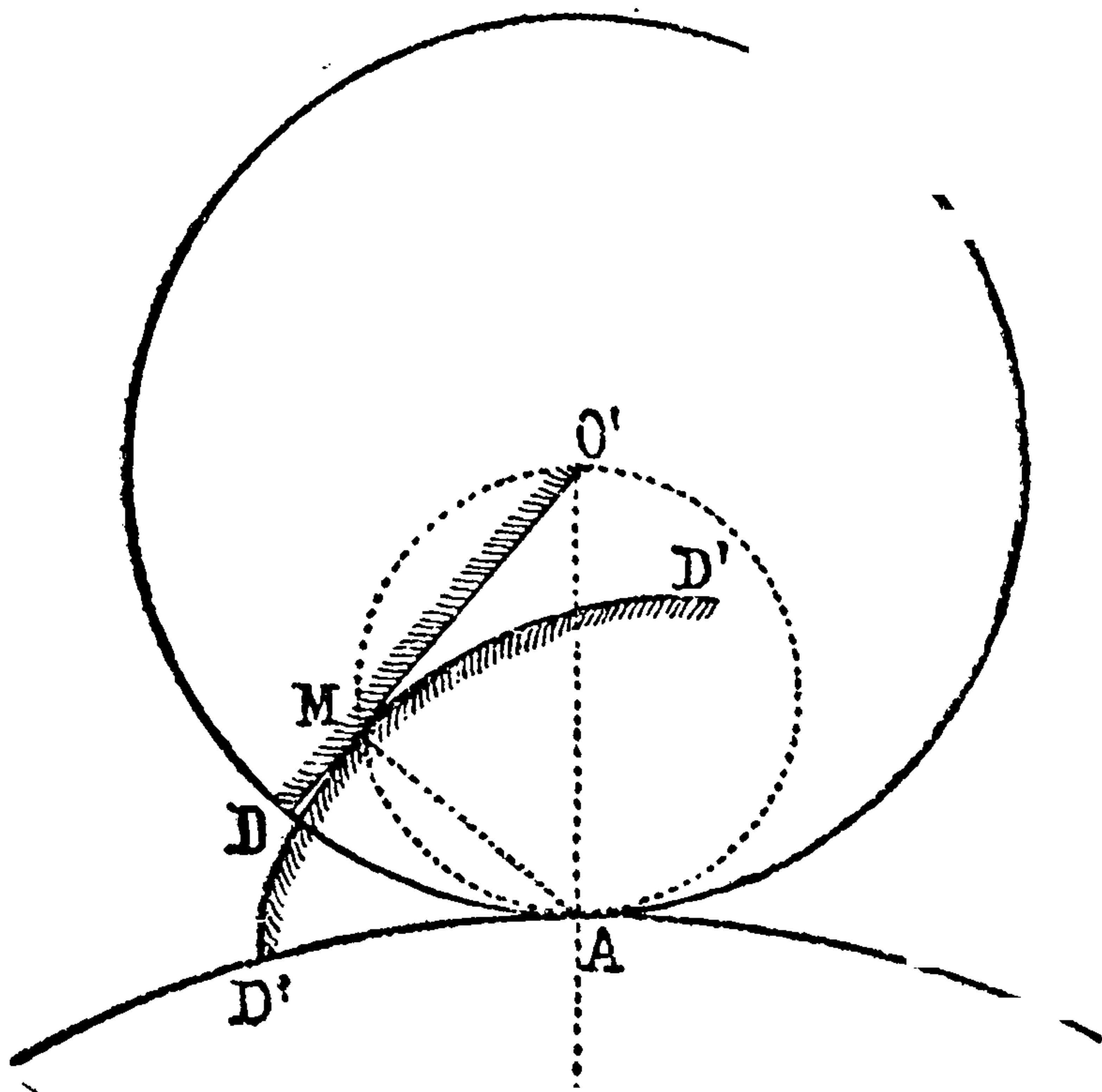

to its primitive circle and with an epicycloidal part exterior, generated by a circle with a diameter equal to the radius of the primitive circle of the other wheel. Thus, for example (Fig. 60), the circle  $O''$  furnishes in its successive rollings a flank  $O'A$  for the wheel  $O'$  and a curve  $AD$  for the wheel  $O$ . The circle  $O_1''$  furnishes in an analogous manner a flank  $OA$  for the wheel  $O$  and a curve  $AD'$  for the wheel  $O$ .

This combination is called "reciprocal" flank gearing. One can, therefore, say that *in reciprocal flank gearings the driving takes place on both sides of the line of centers*.

Let us add that the form of reciprocal flank gearings cannot be employed for interior gearings.

226. Two wheels with plane interior flanks and epicycloidal curves exterior to the primitive circles should, according to the generation of their profiles, be made especially for each other, since a wheel cannot gear regularly in several others of different diameters. This inconvenience is avoided for a series of wheels that one wishes to make gear with the same wheel, by replacing in the wheels of the series the straight flanks by curves, one chooses for generat-

Fig. 59



ing circle of these interior curves and of the corresponding exterior curve of the particular wheel, a constant circle whose diameter differs the least possible from the radii of the wheels of the series.

One encounters in horology an example of this case in the gearings of the dial wheels and the setting wheels. The cannon pinion drives the minute wheel, in which also gears the main setting wheel; this drives, in its turn, the small setting wheel (168).

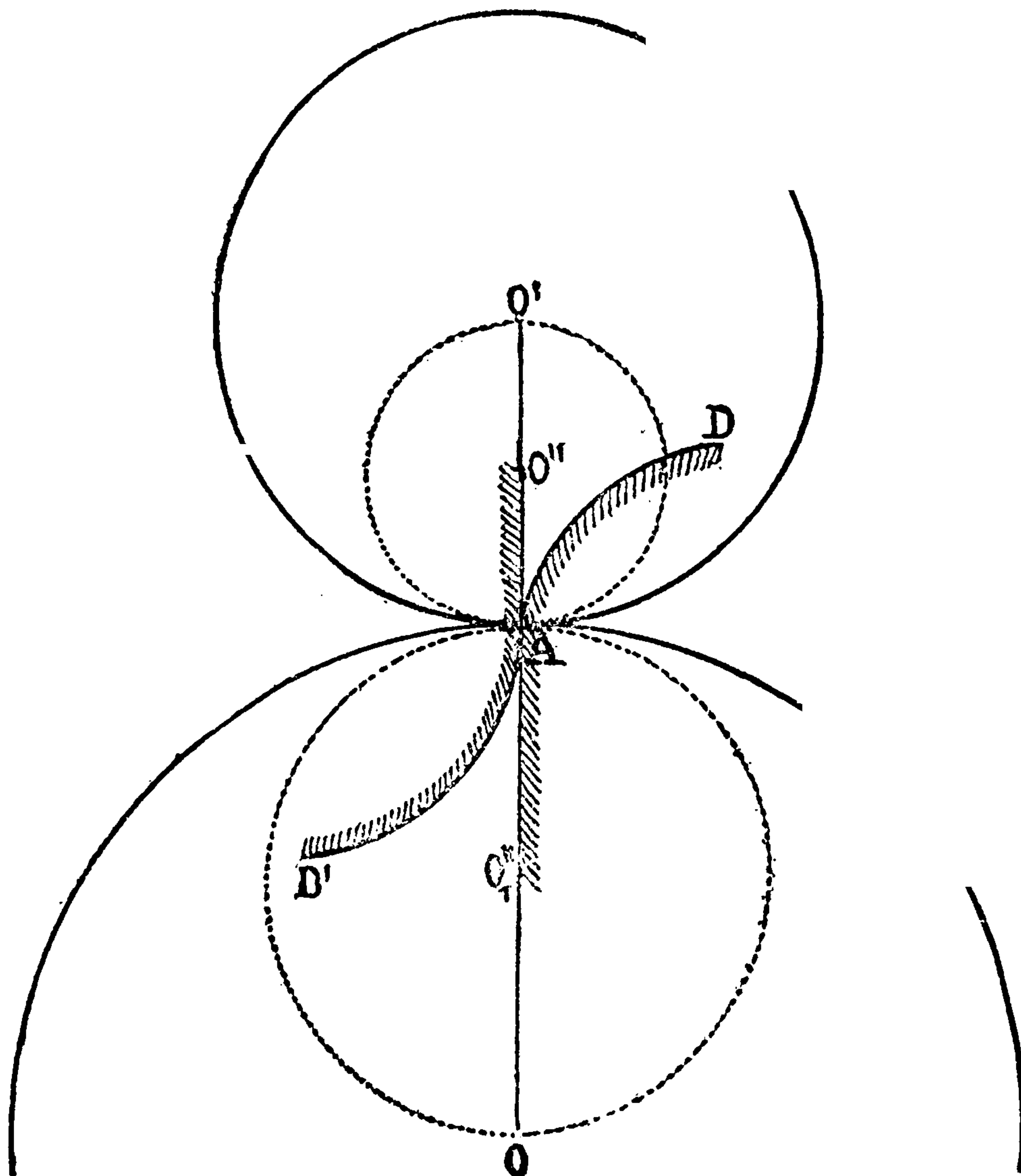

Fig. 60

An inverse movement is produced when the hands of the watch are set to the hour, and it is then the small setting-wheel which drives the other wheels.

One can, in this case, take the circle  $O''$  half of the primitive circle of the cannon pinion, as generating form of the exterior epicycloids of the wheels and afterwards make this same generating circle roll in the interior of each of the primitive circumferences considered, in order to obtain the interior form of the teeth, this form is then a "hypocycloid" (Fig. 61).



In practice, one substitutes very often straight lines for these hypocycloids, and thus one obtains a general outline recalling that of the flank gearings, although incorrect from the point of view of its construction.

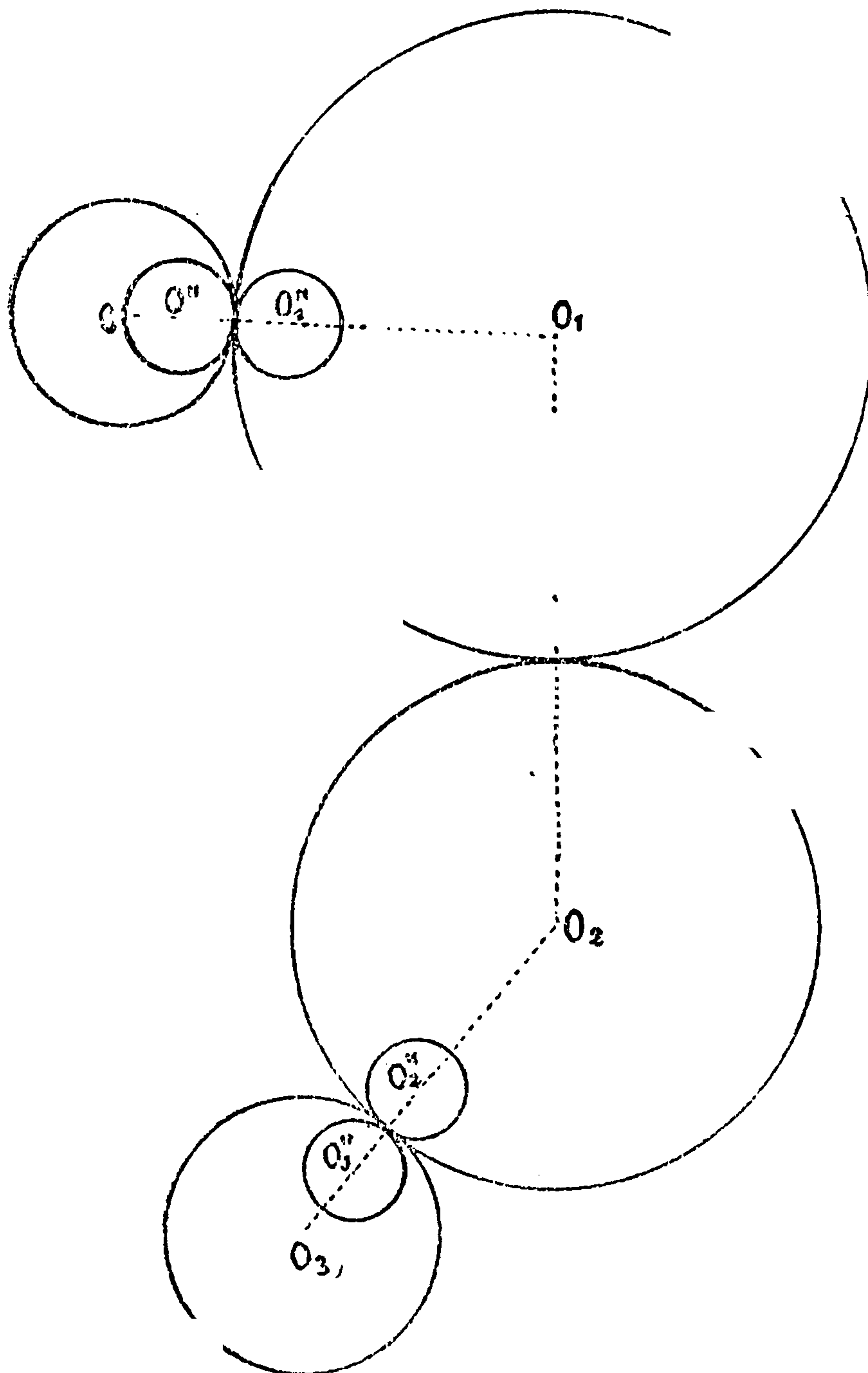

Fig. 61

**226 a. Determination of the Profile of a Tooth Corresponding to a Profile Chosen Arbitrarily** (according to Reuleaux). Suppose given  $a b c d e f g . . . i j k$  the profile chosen,  $A$  and  $B$  the primitive circumferences of the two wheels whose respective centers are  $O$  and  $O'$  (Fig. 61 a).

One draws the normals  $a_6, b_5, c_4, . . . 2h, 3i, 4j, 5k$ , to the profile given. Through the points  $a, b, c, d . . . i, j, k$ , one passes arcs of circles described from  $O'$  as center. From  $S$  as center with





**THIS PAGE IS LOCKED TO FREE MEMBERS**

Purchase full membership to immediately unlock this page

# DELVE INTO FANTASY, MAGIC, MYTHOLOGY & FOLKLORE

Forgotten Books'  
Full Membership gives  
access to 797,885 ancient  
and modern, fiction and  
non-fiction books.

**Continue**

\*Fair usage policy applies



inclined on the line of centers and passing through the point of tangency of the primitive circles, the rolling of this line around a tangent circle  $EE$ , interior to the primitive circumference of the wheel, will cause to be described by a point  $M$  of this line an evolvent  $DD$ . The rolling of the same line around a circle tangent, but interior, to the primitive circumference of the pinion, will cause to be described by the same point  $M$  a second evolvent  $D'D'$ , which is the form of the conjugated tooth.

It is clear that the rotation of a line tangent to a circle is effected in the same manner when, according to the condition established, it must be accomplished on the exterior of the wheel's primitive circle and on the interior of the pinion's primitive circle.

Remark : Let us further state the fact that an evolvent of a circle is nothing more than an epicycloid described by a point of a generating circle whose radius is infinite.

### **Teeth-Range.**

**227.** Up to the present, before approaching the details relative to the distribution of the teeth on their wheels, we have been occupied solely with the determination of the curves, or profiles of contact, by which these teeth mutually drive each other, without determining the points where they terminate. The time has now come to pay attention to these questions.

From the geometrical point of view, a single tooth could, strictly speaking, suffice for the transmission of the movement ; but, in practice, there would result complications and physical impossibilities, independently of the obstacles also very serious, arising from friction. One furnishes, therefore, the wheels with several teeth, and it is, for this reason, necessary to make them all identical.

Each tooth has two profiles. Strictly speaking, the posterior face could be left any shape ; such are, for example, the teeth called "wolf," in some gearings for stem winders. It happens, however, often enough, in mechanics, that sometimes one wheel drives another, and sometimes it is driven by the other ; therefore, the movement takes place in both directions. It is best, for this reason, to construct the two faces alike. The tooth is then "symmetrical" with relation to a radius of the primitive circle, which is, in some degree, its "bisectrix."



The teeth being identical and their number a whole number, they, therefore, divide the primitive circumference into a certain number of equal parts between them, which is called the “*pitch*” of the gearing (184). This pitch is subdivided into three parts, the *full*, the *blank* and the *play*. The full is the space measured on the primitive circle and occupied by the material of the wheel; the blank is the surplus, which should remain clear to allow the introduction of the conjugate tooth; the play is an accessory blank, which does not seem at first to be necessary from the geometrical view-point, but which, in reality, is indispensable.

Numerous causes render the play necessary for the action of gearings: for instance, imperfections in the divisions of the wheels by the machine, the shake necessary to the pivots in their holes, the expansion of the bodies of which the mobiles are formed and the inevitable introduction of foreign bodies in the wheel teeth, are all so many reasons for this necessity.

**228.** It can be said that the play is the relation of the arc not occupied by the sum of the breadths of the tooth and of the leaf, to the pitch of the gearing.

If we represent by  $p$  the pitch of the gearing, by  $a$  the length of the arc occupied by the tooth on the primitive circumference and by  $b$  the length occupied on this same circumference by the corresponding tooth of the other wheel, the play  $j$  will be expressed by the formula

$$j = \frac{p - a - b}{p}.$$

If, for example, we had for a given case

$$p = 6 \text{ mm.}, \quad a = 2.8, \quad \text{and} \quad b = 2.8,$$

one would obtain the play of the gearing

$$j = \frac{6 - 2.8 - 2.8}{6} = \frac{1}{15}.$$

**229.** To determine the quantity of play necessary for a gearing, one has to examine two conditions: First the solidity of the wheel teeth and then the space to be reserved for the free passage of small foreign bodies, such as dust or the particles which, inevitably, are detached from the bearing surfaces on account of wear. One or the other of these conditions can have the predominance, according to the nature of the gearing.



Thus, in the gearing of stem-winding works, of the setting gear, the rack of a repeating watch, etc., the conditions inherent to the solidity of the wheel teeth should evidently predominate. In the gearing of the fourth wheel with the escape pinion, there must necessarily be reserved space for foreign bodies.

The same two conditions should also guide us in the choice of the form to give to the part of the wheel teeth which forms what is called the depth of the teeth. Thus, when one desires a solid set of teeth one chooses in preference the rounded depth, as Fig. 62.

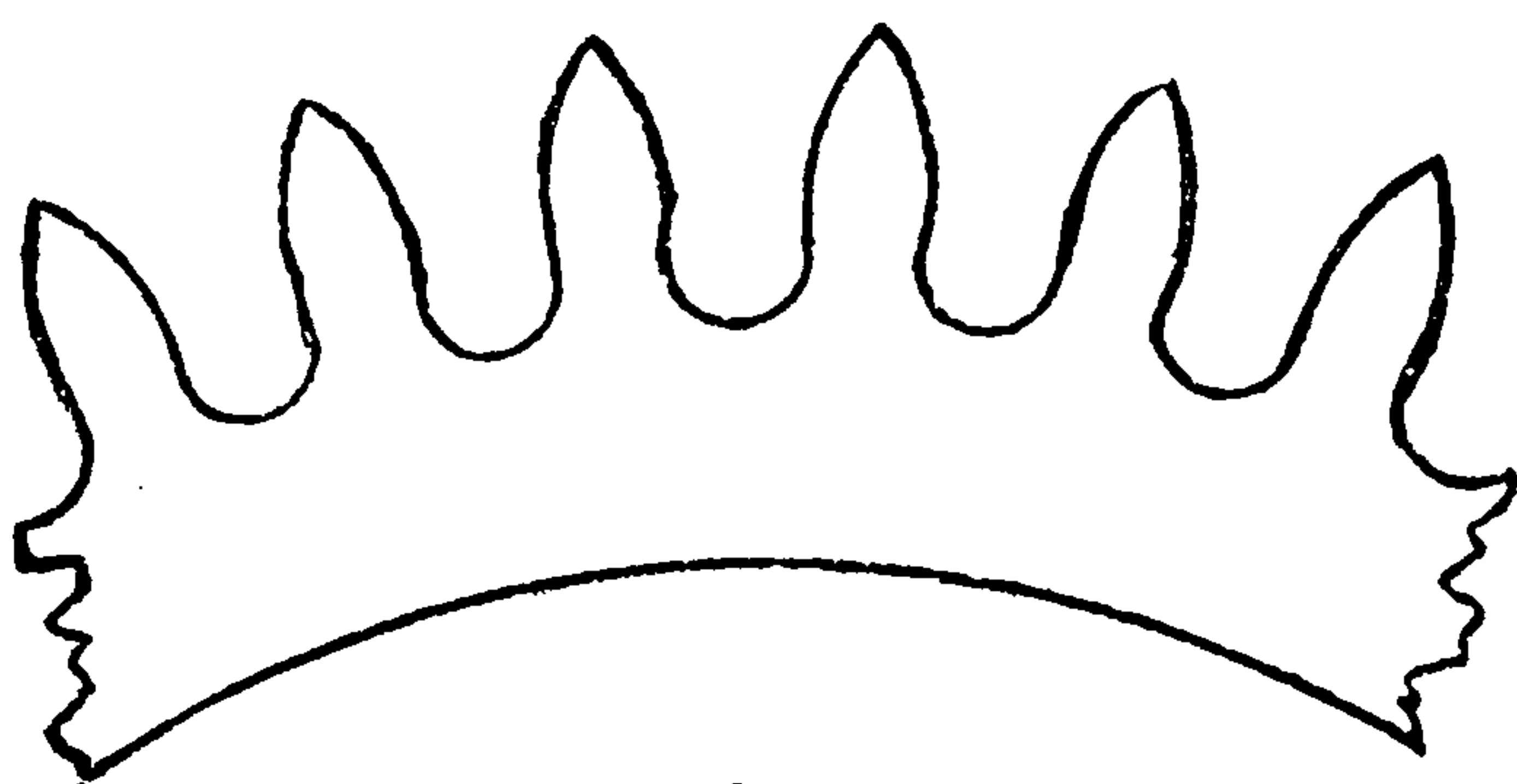

Fig. 62

If, on the contrary, one wishes to construct a set of teeth leaving place for foreign bodies, one will adopt a form such as is indicated in Fig. 63; in this last case, one can also use the lantern gearing.

**230.** In the gearings of stem-winding mechanism, of

change wheels for setting, etc., one divides the play equally between the two wheels; in the gearings of the train of the watch one deducts it from the pinion leaf alone, for the reason that this last mobile is made of tempered steel and offers, consequently, more resistance than the brass of which the wheel is made. The solidity of the leaf is, furthermore, also increased by its greater transverse length.

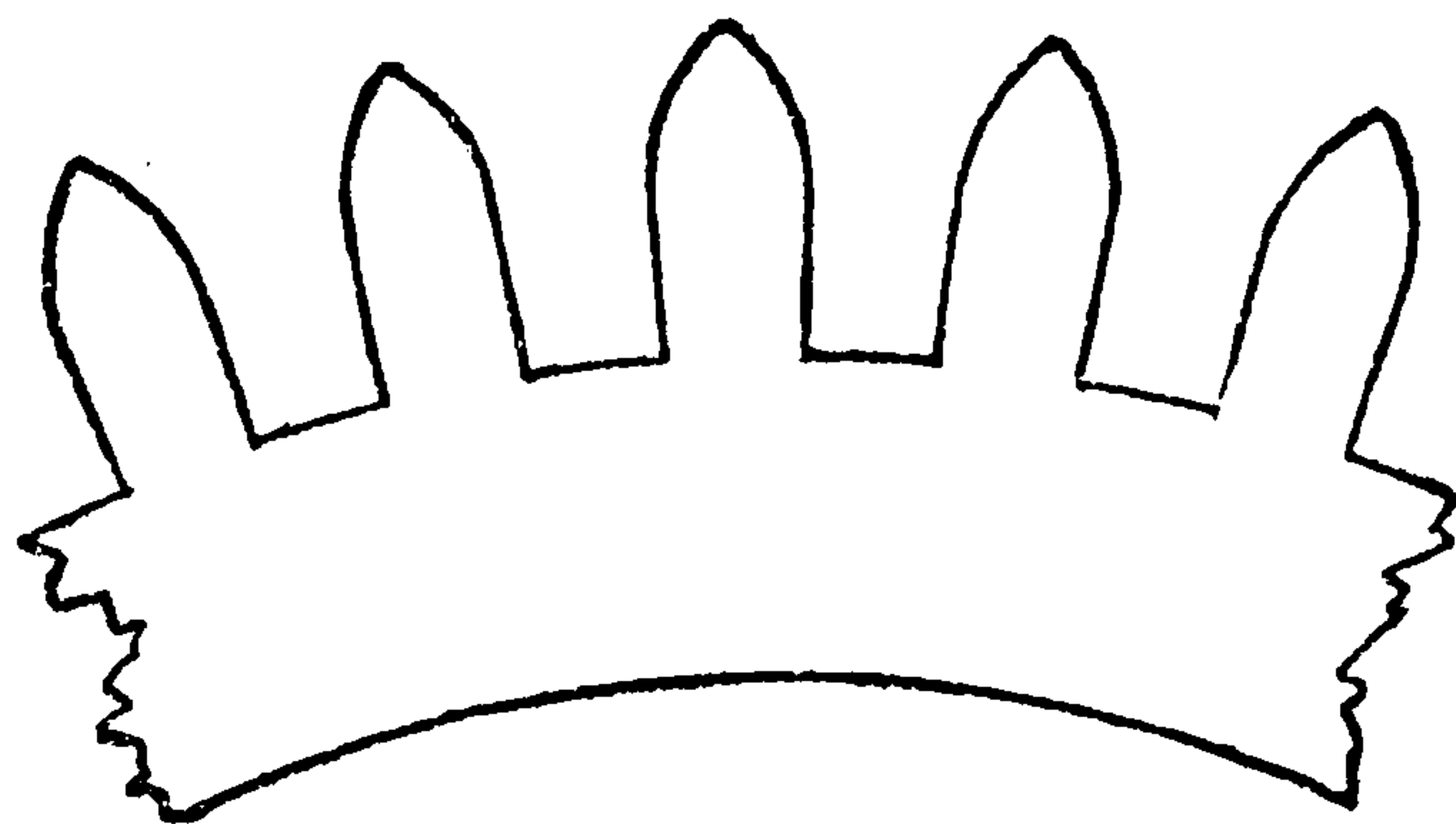

Fig. 63

Another reason which makes us deduct the play from the leaf, is that the wheels generally drive the pinions; consequently, it is the profile of the tooth which drives the flank of the leaf after the line of centers. The curve of the tooth, therefore, must be of sufficient length to be able to drive the flank far enough to prevent, as much as possible, the tooth following entering into contact before the line of centers. This, however, is not always possible for the pinions of low numbers.

**231.** For the mobiles of the train, the general rule adopted is to give in the wheel half of the pitch to the tooth and the other





**THIS PAGE IS LOCKED TO FREE MEMBERS**

Purchase full membership to immediately unlock this page



# HISTORY

Tens of thousands of important historical sources, many previously unobtainable, are now available for the first time with a Forgotten Books Full Membership.

Unlimited Access  
\$8.99/month

**Continue**

\*Fair usage policy applies



the point  $A$  to the line  $AA'$ . One divides the generating circumference and the base into the same number of equal parts, 12, for example, which are numbered in the manner indicated by the figure. From the point of the center  $O$  one draws a straight line parallel to the base; this line will contain the successive places transversed by the center of the generating circle during its rolling. Let us indicate on this parallel the positions of the center  $O$ , corresponding to the positions of the circle when it is in contact with the base at the division points, and, from each of these centers, let us describe circumferences with diameters equal to that of the generating circle.

Let us remark that when the generating circle has arrived at the center  $r_0$ , the point  $r_1$  of its circumference is lowered to  $r$ , and the point  $A$ , whose movement describes the cycloid, should be elevated to a height equal to the distance which the point  $r_1$  is lowered.

Thus, in this new position, the point  $A$  should be found on the circumference whose center is at  $r_0$  and also on a line parallel to the base passing through  $r_1$ .

In the same manner, we could determine the successive positions occupied by the point  $A$  while the center of the gene-

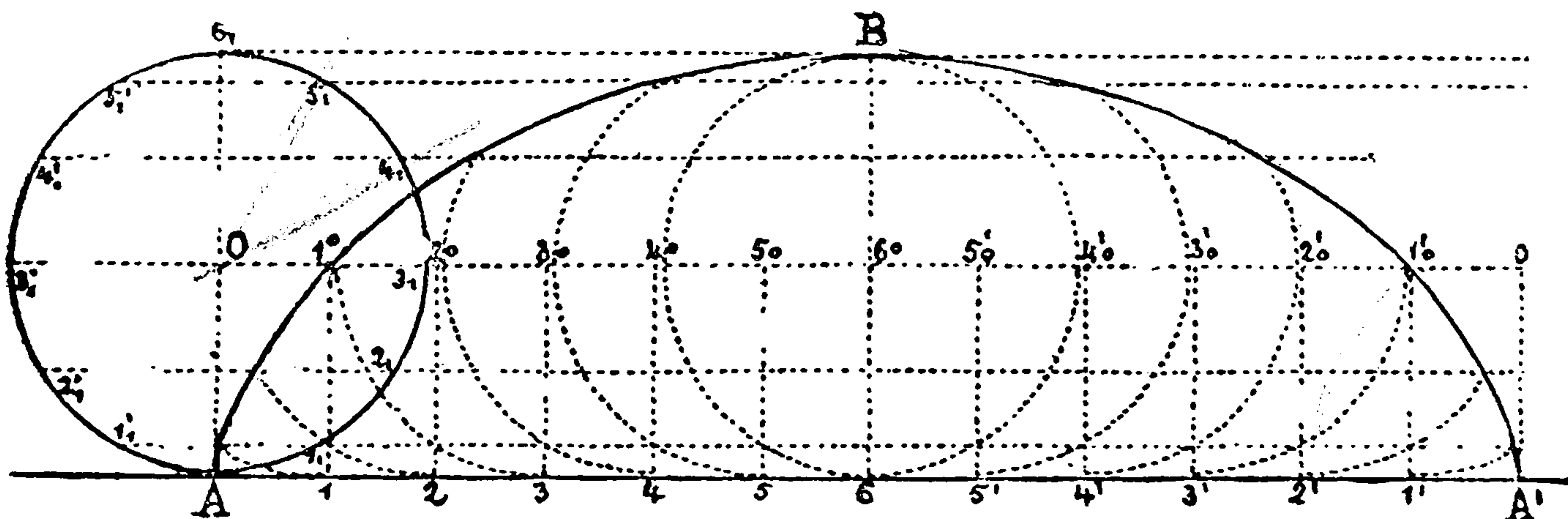

Fig. 64

rating circle is found at  $2_0, 3_0, 4_0$ , etc., and on connecting all the points thus obtained by a continuous line, one obtains the cycloid  $ABA'$  sought.

**237. Drawing of the Cycloid of a Continuous Movement.** One understands that the circle  $O$  is a circular plate on the circumference of which a point or pencil  $A$  is fixed (Fig. 64). If one causes the plate to turn without slipping along a straight rule whose edge coincides with  $AA'$ , the point or pencil  $A$  will describe the cycloid of a continuous movement.



**238. Normal and Tangent to the Cycloid.** Let  $M$  be any point whatever on the cycloid  $A M B$  (Fig. 65), through which it is desired to draw a normal, then a tangent. Having traced the base  $A A'$  and its parallel  $E E'$  containing the places occupied successively by the centers of the generating circle during the rolling, we will find the center  $O$  of the generating circle corresponding to the point  $M$  of the cycloid, by tracing from the point  $M$  with an opening of the compass equal to the radius of the generating circle, an arc of a circle passing through the line  $E E'$ . The point of intersection  $O$  will be the center of the generating circle.

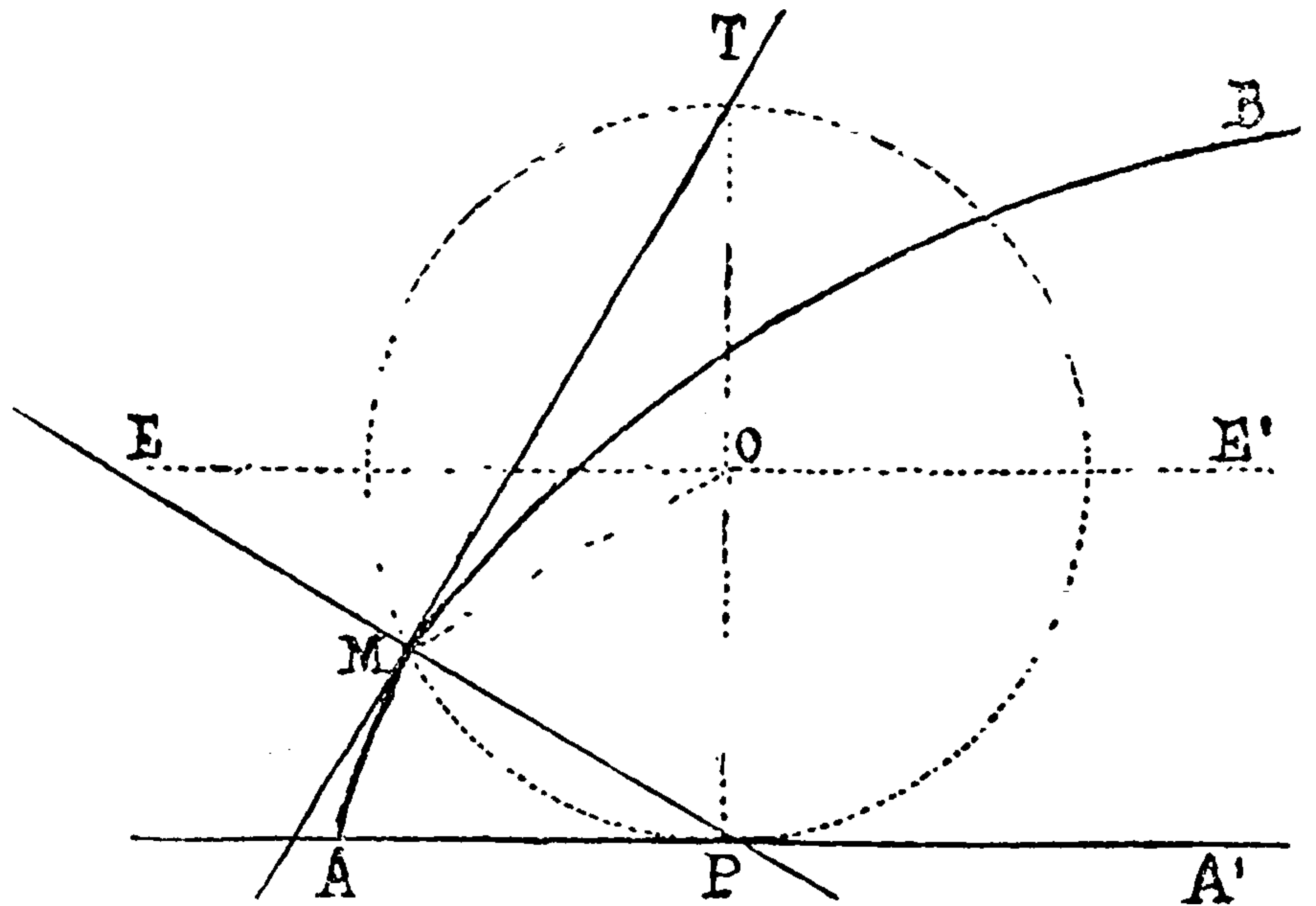

Fig. 65

Dropping from the point  $O$  a perpendicular on the base  $A A'$ , the point  $P$  will be the momentary center of rotation of the generating circle. Its movement is composed of a movement of translation parallel to the base and of a movement of rotation around its center  $O$ . The point  $P$  being thus the center of this combined movement, the point  $M$  will describe an arc of a circle infinitely small around this momentary center; the straight line  $M P$  being the radius of this arc will consequently be the normal to the point  $M$ , sought. The tangent being perpendicular to the normal, should pass through the point  $T$  of the generating circle; one knows, in fact, that every angle inscribed in a semi-circumference is a right angle.

**239. Evolute and Radius of Curvature of the Cycloid.** The evolute  $A'_1 A$  of the semi-cycloid  $A B$  is a semi-cycloid equal to its evolvent (218).

Let  $A A'$  be the base (Fig. 66),  $B f$  the axis of the cycloid generated by the point  $M$  of the circumference  $T M P$ . Let us describe a circumference on the diameter  $P P' = T P$ ; through the point  $P'$  draw  $E F$  parallel to  $A A'$ ; then draw the lines  $M M'$ ,  $M T$  and  $M' P'$ . On account of the equality of the angles  $M P T$



and  $P' P M'$ , the two right-angled triangles  $P M T$  and  $P M' P'$  are also equal and one has

$$M' P = P M,$$

from whence

$$M M' = 2 P M.$$

The straight line  $M M'$  is the *radius of curvature* of the point  $M$ ; that is to say, the radius of the circumference which has two

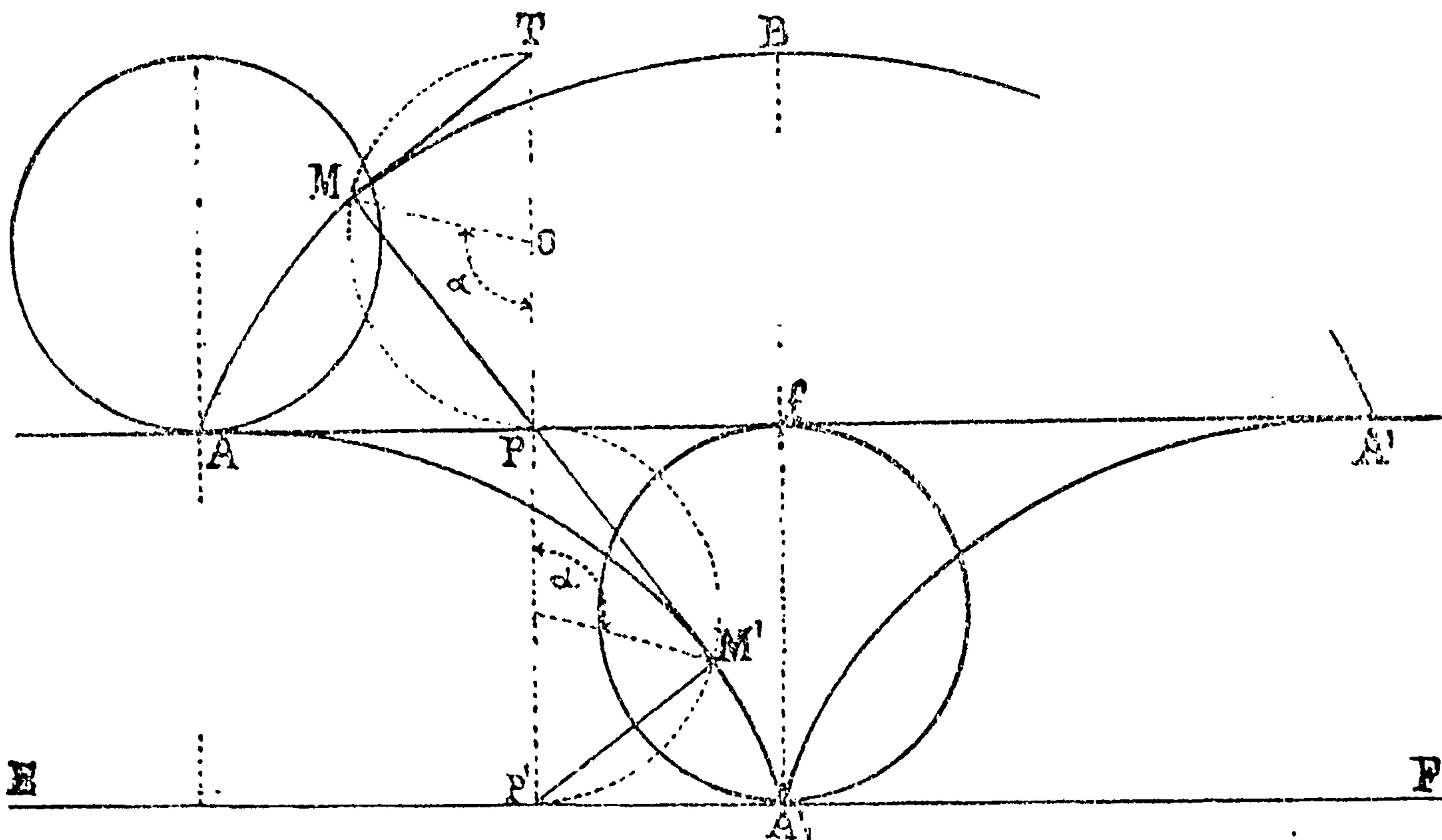

Fig. 66

consecutive elements infinitely small, common with the curve at this point.

Thus the radius of curvature at any point whatever  $M$  of the cycloid is twice the portion  $M P$  of the normal comprised between the curve and the base.

Designating the angle  $M O P$  by  $\alpha$ , by  $\delta$  the radius of curvature and by  $r$  the radius of the generating circle, one has

$$\delta = 4 r. \sin \frac{1}{2} \alpha$$

It is thus easy to see that the foot  $A'_1$  of the evolute corresponds with the summit  $B$  of the evolvent, while the summit of the evolute blends with the origin of the evolvent.

**240. Length of the Cycloid.** The length of the portion  $A M'$  of the cycloid  $A M' A'_1$  is equal to the length of the radius of curvature of the point  $M$  of the cycloid  $A M B$ ; it is equal to





**THIS PAGE IS LOCKED TO FREE MEMBERS**

Purchase full membership to immediately unlock this page

# DELVE INTO FANTASY, MAGIC, MYTHOLOGY & FOLKLORE

Forgotten Books'  
Full Membership gives  
access to 797,885 ancient  
and modern, fiction and  
non-fiction books.

**Continue**

\*Fair usage policy applies



In the same manner we could determine as many points as we wished, and on connecting them by a continuous line we would obtain the epicycloid sought, as it is represented in Fig. 67.

**243. Drawing of the Epicycloid of a Continuous Movement.**

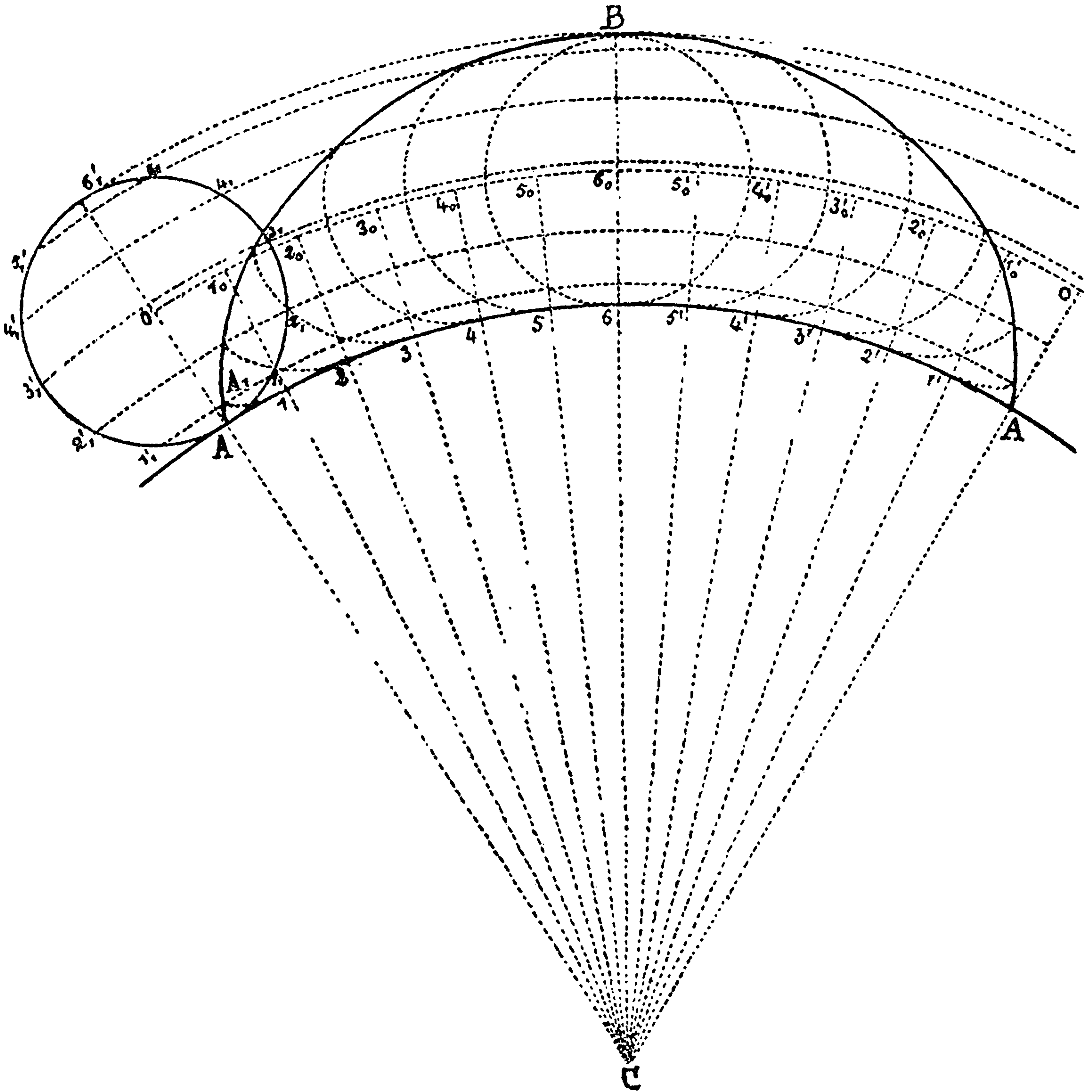

**Fig. 67**

$C$  and  $O$  being circular plates and  $A$  a pencil point fixed in the circumference  $O$ , one understands that on making the plate  $O$  roll without slipping on the plate  $C$ , the pencil will trace the epicycloid  $A B A'$  of a continuous movement.

**244. To Draw a Normal, then a Tangent to the Epicycloid.** Identical considerations to those which have enabled us to draw a



normal and a tangent to the cycloid furnish us the means of drawing these same lines to the epicycloid. If it is desired to draw a normal to the point  $M$  of the epicycloid  $A M B$  (Fig. 68), we commence by seeking the center of the generating circle belonging to the point  $M$  of the epicycloid, by laying off from this point  $M$ , the radius of the generating circle, on the circumference around which it is moved during the rolling of its center. From the point  $O_1$  we figure the position of the generating circle and we find the point of tangency  $P$ , of the two circumferences.

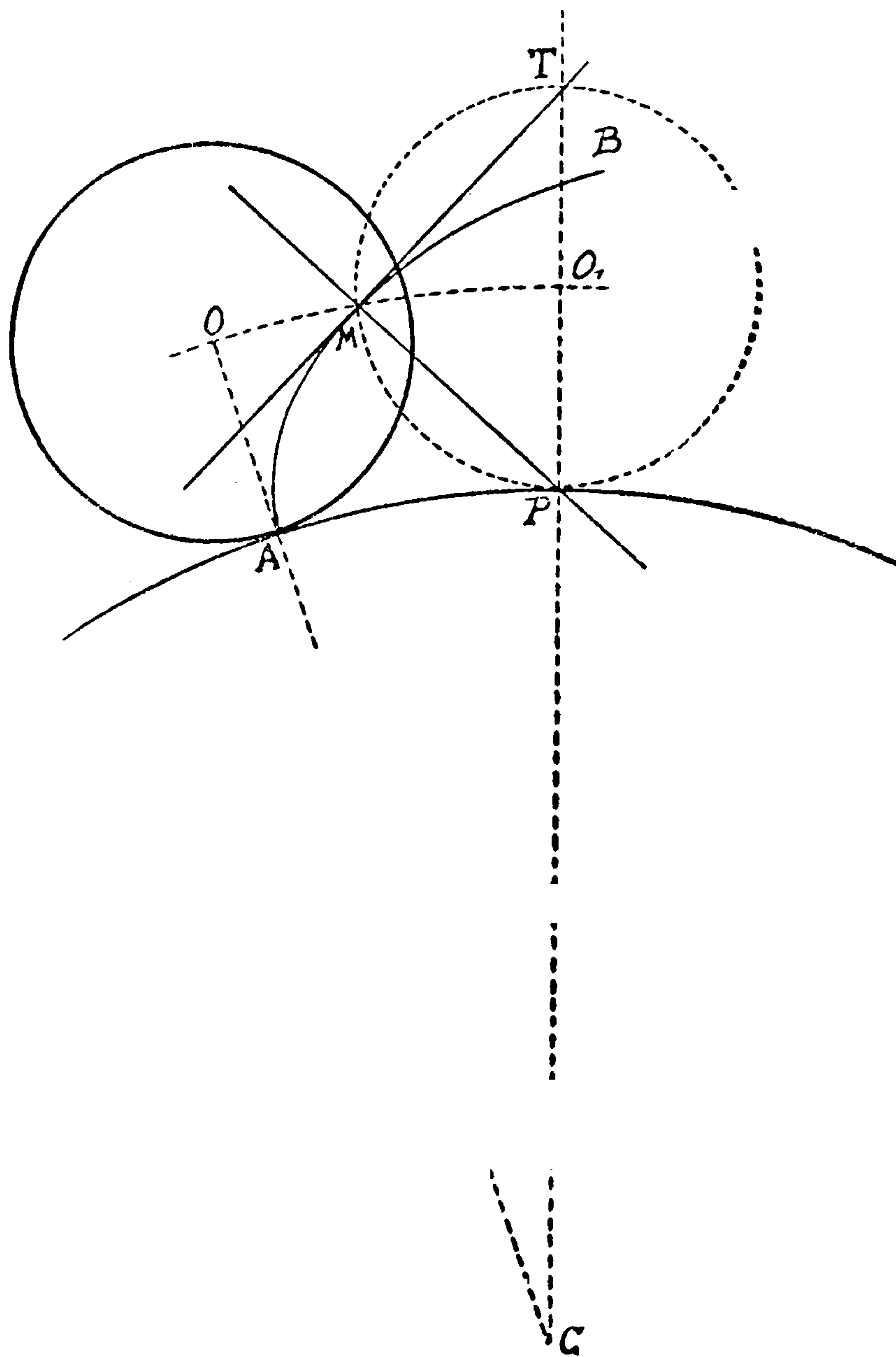

Fig. 68

During an infinitely small period of movement all the points of the generating circle, as also those which are unchangeably connected with them, describe infinitely small arcs of circles. Since the normal of an arc of a

circle unites with the radius, we would have, therefore, the radius  $MP$  as normal to the point  $M$  of the epicycloid  $A M B$ .

On drawing afterward from the point  $M$  a perpendicular to the normal, we would obtain the tangent  $MT$ . This tangent should pass through the point  $T$  of the generating circle, since every angle inscribed in a semi-circumference is a right angle.

**245. Evolute and Radius of Curvature of the Epicycloid.** We have seen that the evolute of a cycloid is a cycloid equal to its evolvent and placed in such a manner that the summit of the evolute coincides with the origin of the evolvent and the summit of the



evolvent is found on the same perpendicular to the base as the origin of the evolute. Moreover, the two bases are parallel to each other and separated from each other the diameter of the generating circle.

As regards the epicycloid, we will see, moreover, that its evolute is a similar curve, but not equal. The summit of the

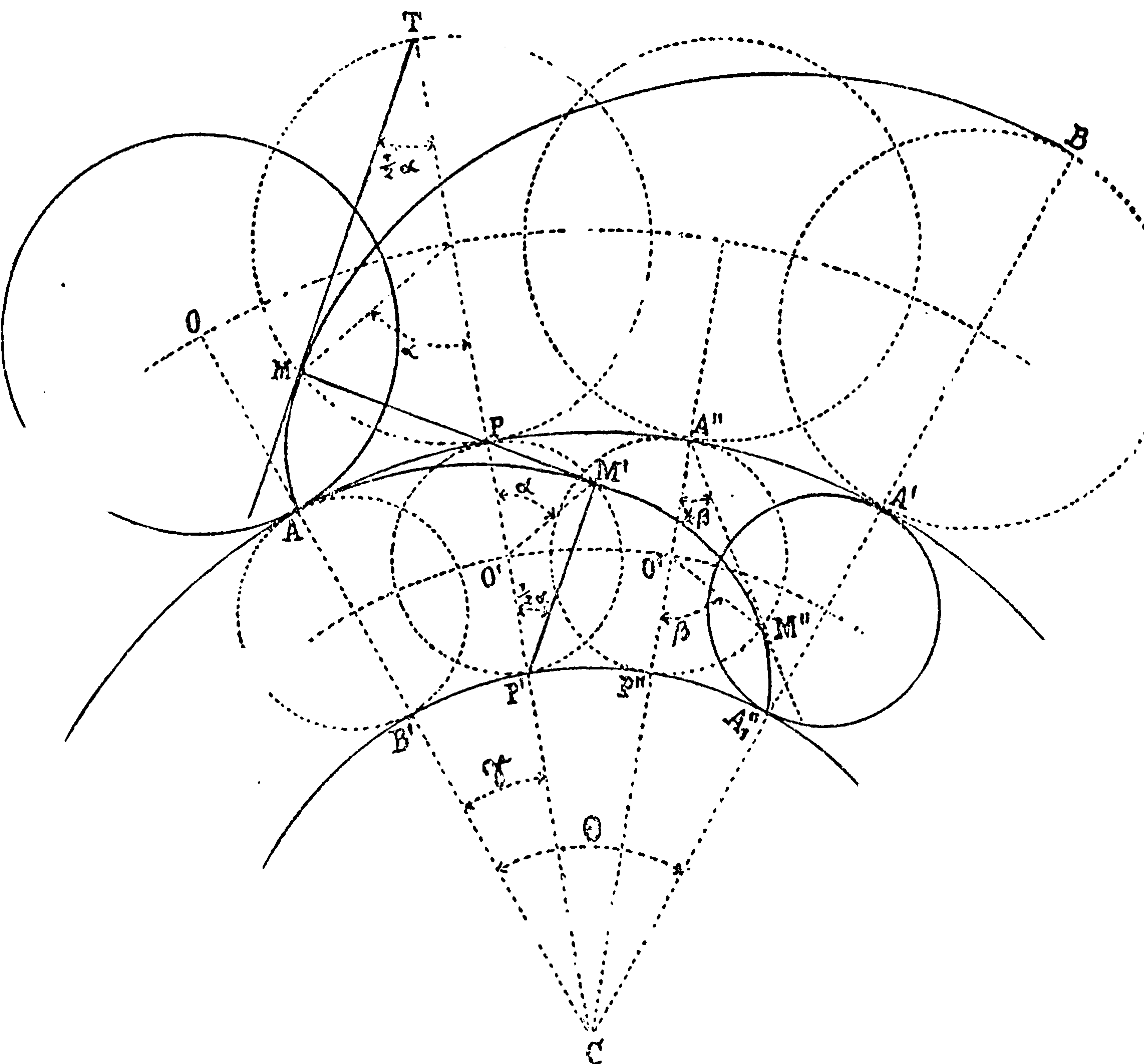

Fig. 69

evolvent and the origin of the evolvent at the point  $A$  (Fig. 69) still coincide ; the summit  $B$  of the evolvent and the origin  $A_1''$  are found on the same radius  $BC$ , but their generating circles are of different diameters.

The two demi-epicycloids are contained in the same angle  $ACB$  which we will designate by  $\theta$ . If we call  $R$  the radius of the base of the evolvent and  $r$  that of its generating circle,  $R'$  the radius of the





**THIS PAGE IS LOCKED TO FREE MEMBERS**

Purchase full membership to immediately unlock this page

# HISTORY

Tens of thousands of important historical sources, many previously unobtainable, are now available for the first time with a Forgotten Books Full Membership.

Unlimited Access  
\$8.99/month

**Continue**

\*Fair usage policy applies





When the generating circle with radius  $r'$  has rolled without slipping on the base  $B' A_1''$ , this length of arc  $B' A_1''$  is equal to  $\pi r'$ . One has also

$$\pi r' = \text{arc } P M' + \text{arc } M' P',$$

then

$$\begin{aligned} \text{arc } P' M' &= \text{arc } P' A_1'', \\ \text{arc } P M &= \text{arc } B' P', \end{aligned}$$

and as

$$\begin{aligned} \text{arc } P M' &= r' \times \text{angle } P O' M', \\ \text{arc } B' P' &= R' \gamma, \end{aligned}$$

one will then have

$$r' \times \text{angle } P O' M' = R' \gamma,$$

from whence

$$\frac{r'}{R'} = \frac{\gamma}{\text{angle } P O' M'}.$$

But as we have

$$\frac{r'}{R'} = \frac{r}{R},$$

we will also have

$$\frac{\gamma}{\alpha} = \frac{\gamma}{\text{angle } P O' M'},$$

from whence  $\alpha = \text{angle } P O' M'$ .

The point  $M'$  thus determined belongs, therefore, properly to the evolute.

Since the angle  $M T P = M' P' P = \frac{1}{2} \alpha$ , and since the angles at  $M$  and at  $M'$  are right angles, the straight lines  $M P$  and  $P M'$  will have the same alignment.

**247.** The straight line  $M M'$  representing the line developed is the *radius of curvature* of the point  $M$  of the evolute and the length of the arc  $A M'$  developed.

We have, in effect,

$$M M' = M P + P M';$$

or

$$M P = 2 r \sin \frac{1}{2} \alpha \text{ and } P M' = 2 r' \sin \frac{1}{2} \alpha;$$

therefore,

$$M M' = 2 (r + r') \sin \frac{1}{2} \alpha.$$

Designating the radius of curvature by  $\delta$  and replacing  $r'$  by

$$\frac{R - R'}{2} = \frac{R}{2} \left( 1 - \frac{R}{R + 2r} \right),$$

we will have

$$(2) \quad \delta = 2 r \left( 1 + \frac{R}{R + 2r} \right) \sin \frac{1}{2} \alpha = 4 r \frac{R + r}{R + 2r} \sin \frac{1}{2} \alpha.$$

For a numerical example, let  $r = 20$  mm.,  $R = 60$  mm.,  $\alpha = 60^\circ$ ; we will obtain successively,



$$\frac{R}{R + 2r} = \frac{60}{60 + 40} = 0.6 \text{ and } 1 + \frac{R}{R + 2r} = 1.6.$$

$$2r \left( 1 + \frac{R}{R + 2r} \right) = 40 \times 1.6 = 64.$$

then

$$\begin{aligned} \text{Log. } 64 &= 1.80618 \\ + \text{ " } \sin \frac{1}{2} \alpha &= \underline{9.69897} \\ \text{Log. } \delta &= 1.50515, \text{ from whence } \delta = 32 \text{ mm.} \end{aligned}$$

For  $\frac{1}{2} \alpha = 90^\circ$ , the radius of curvature  $\delta = A_1''$ ,  $B = 64$  mm.

**248.** We know that in flank gearings, the radius of the generating circle of the epicycloid is equal to half the primitive radius of the pinion which we will designate by  $r'$ ; one has, therefore, in this case (2),

$$2r = r'.$$

The radius  $R$  takes, then, the notation  $r$ , primitive radius of the wheel. The angle  $\frac{1}{2} \alpha$  is the angle formed by the flank of the pinion leaf and the line of centers. Under these conditions, the formula (2) becomes

$$\delta = r' \left( 1 + \frac{r}{r + r'} \right) \sin \frac{1}{2} \alpha = r' \left( 1 + \frac{1}{1 + \frac{r'}{r}} \right) \sin \frac{1}{2} \alpha;$$

or, again,  $n$  and  $n'$  being the numbers of teeth (184),

$$(3) \quad \delta = r' \left( 1 + \frac{1}{1 + \frac{n'}{n}} \right) \sin \frac{1}{2} \alpha = r' \left( \frac{2 + \frac{n'}{n}}{1 + \frac{n'}{n}} \right) \sin \frac{1}{2} \alpha.$$

**249.** The formulas (2) and (3) show that at the origin, the radius of curvature is nothing. This fact indicates that at this point the curve is united to the primitive radius of the wheel without forming an abrupt angle.

The radius of curvature increases, afterward, proportionately to the sine of the angle formed by the flank of the leaf and the line of centers; it becomes greatest when the angle  $\frac{1}{2} \alpha$  is equal to  $90^\circ$ ; it diminishes then to become again zero for  $\frac{1}{2} \alpha = 0$ , that is to say, at the point of the curve's inflection.

**250. Length of the Epicycloid.** The length of arc of a curve is equal to the length of the line developed. Thus (Fig. 69)

$$\text{arc } A M' = M M' 2r \left( 1 + \frac{R}{R + 2r} \right) \sin \frac{1}{2} \alpha.$$

One has most frequently occasion to determine the length of an epicycloidal arc calculated from its origin; it is, therefore, necessary to determine its length from the point  $A_1''$ . For this purpose it is equally proper to take in place of the angle  $PP'M'$



its complementary  $P' P M'$ , which we will designate by  $\frac{1}{2} \beta$ . For the point  $M''$  the angle  $\frac{1}{2} \beta$  becomes thus equal to  $P'' A'' M''$  which obliges us to change the sine into cosine.

To obtain the length  $A_1'' M''$  of the epicycloid  $A_1'' M'' A$ , let us remark that this length is equal to  $A A_1'' - A M''$ .

Therefore,

$$l = 2r \left( 1 + \frac{R}{R + 2r} \right) - 2r \left( 1 + \frac{R}{R + 2r} \right) \cos \frac{1}{2} \beta,$$

or

$$l = 2r \left( 1 + \frac{R}{R + 2r} \right) \left( 1 - \cos \frac{1}{2} \beta \right);$$

$r$  is here the radius of the generating circle of the epicycloid  $A M B$  and  $R$  the radius of its base; so we have (245)

$$r = \frac{r'}{R'} (R' + 2r') \text{ and } R = R' + 2r'.$$

On substituting these two values in the above equation, we will obtain the length of the epicycloidal arc, calculated from the point of origin, thus:

$$(4) \quad l = 4r' \left( 1 + \frac{r'}{R'} \right) \left( 1 - \cos \frac{1}{2} \beta \right).$$

**251. First Application.** A wheel of 80 teeth can drive the leaf of a pinion with 10 leaves, after the line of centers, an angle  $\frac{1}{2} \beta = 34^\circ 45' 48''$  (257); what is the length of the epicycloidal arc of the tooth, starting from its origin when the primitive radius of the wheel is 10 mm.?

Solution: The radius  $r'$  of the generating circle of the epicycloid is  $\frac{1}{16} \times 10$ . We have, therefore,

$$1 + \frac{r'}{R'} = 1 + \frac{1}{16} = 1.0625$$

and

$$4r' = 4 \times \frac{10}{16} = 2.5;$$

from whence one obtains

$$4r' \left( 1 + \frac{r'}{R'} \right) = 2.5 \times 1.0625 = 2.65625.$$

The natural expression of  $\cos \frac{1}{2} \beta$  is

$$\cos \frac{1}{2} \beta = 0.821514,$$

it follows

$$1 - \cos \frac{1}{2} \beta = 0.178486.$$

Then

$$\begin{aligned} \log : 4r' \left( 1 + \frac{r'}{R'} \right) &= 0.42427 \\ + \log : (1 - \cos \frac{1}{2} \beta) &= \frac{0.25160 - 1}{\log : l = 0.67587 - 1,} \end{aligned}$$

from whence

$$l = 0.4741 \text{ mm.}$$





**THIS PAGE IS LOCKED TO FREE MEMBERS**

Purchase full membership to immediately unlock this page

# DELVE INTO FANTASY, MAGIC, MYTHOLOGY & FOLKLORE

Forgotten Books'  
Full Membership gives  
access to 797,885 ancient  
and modern, fiction and  
non-fiction books.

**Continue**

\*Fair usage policy applies



a relation between the radius  $\delta$  and the angle  $\theta$ . This relation is complicated, but it has a great importance in the calculations relative to the determination of the total radius of the wheels.

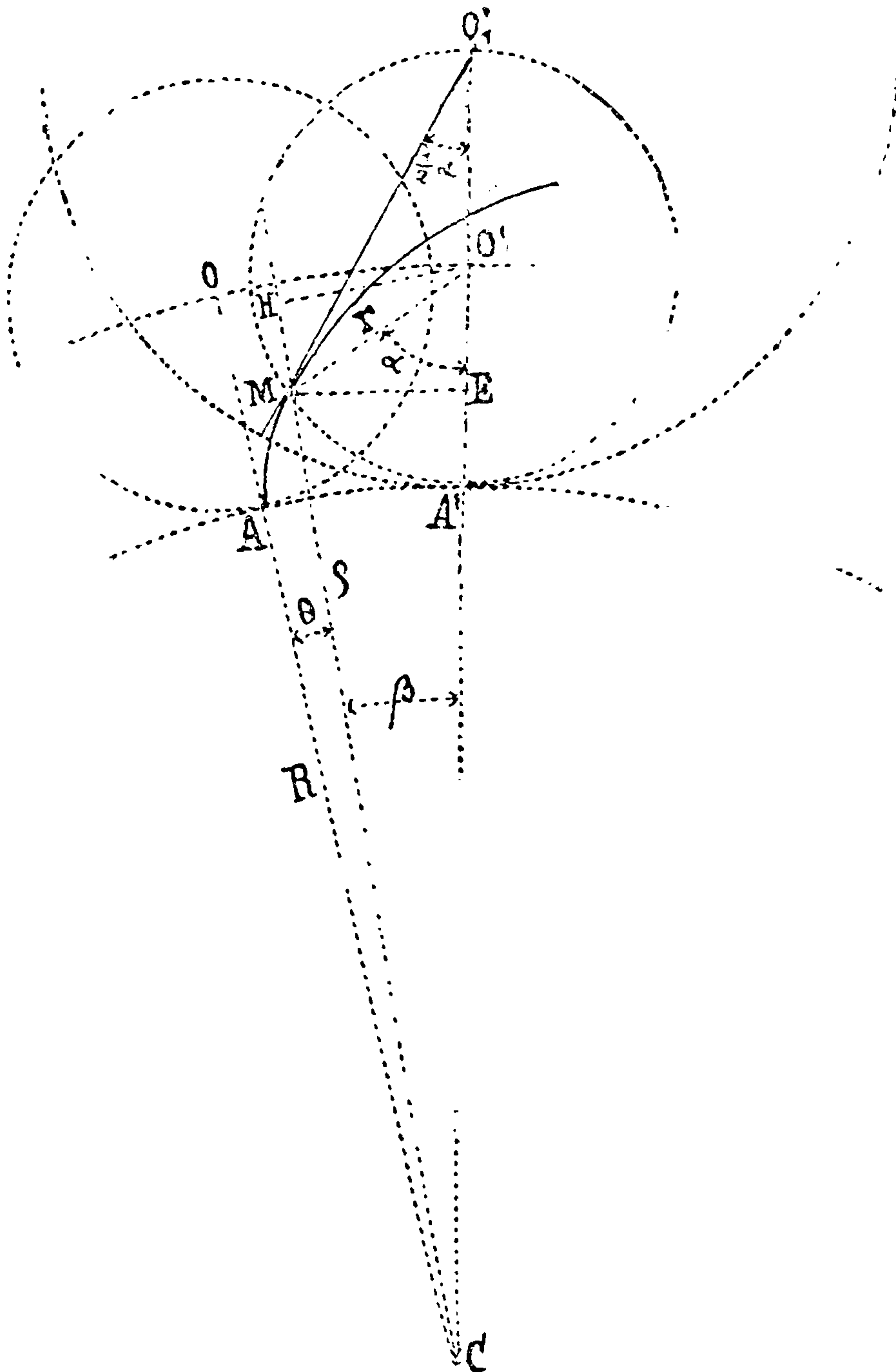

Fig. 70

If the angles  $M O' A' = \alpha$  and  $M C O' = \beta$  are known, we would have the proportion

$$\frac{\delta}{r} = \frac{\sin \alpha}{\sin \beta},$$

from whence

$$\delta = r \frac{\sin \alpha}{\sin \beta}.$$

Let us now seek for a relation between the angles  $\theta$  and  $\alpha$ , and for this purpose project the point  $M$  on the straight line  $C O'$ ; we will thus form two right-angled triangles  $M E O'$  and  $M E C$ . In the first we have

$$M E = r \cdot \sin \alpha,$$

and in the second

$$M E = (R + r - r \cdot \cos \alpha) \text{ tang. } \beta,$$

from whence

$$r \cdot \sin \alpha = (R + r - r \cdot \cos \alpha) \text{ tang. } \beta.$$

On dividing by  $r$ , it becomes :

$$\sin \alpha = \left( \frac{R}{r} + 1 - \cos \alpha \right) \text{ tang. } \beta.$$

But

$$A A' = M A',$$

therefore,

$$r \alpha = R (\theta + \beta).$$



from whence

$$\beta = \frac{r}{R} \alpha - \theta,$$

then

$$(5) \quad \sin \alpha = \left( \frac{R}{r} + 1 - \cos \alpha \right) \text{tang.} \left( \frac{r}{R} \alpha - \theta \right).$$

**255. REMARK.**—One can also project the point  $O'$  (Fig. 70) on the prolongation of  $CM$ , and one thus forms the two right-angled triangles  $O'HM$  and  $O'HC'$ . In the first case, we have

$$O'H = r \cdot \sin (\alpha + \beta),$$

and in the second

$$O'H = (R + r) \sin \beta;$$

from whence

$$r \cdot \sin (\alpha + \beta) = (R + r) \sin \beta.$$

On replacing  $\alpha$  by its value

$$\alpha = \frac{R}{r}(\theta + \beta)$$

and on dividing by  $r$ . it becomes

$$\sin \left[ \frac{R}{r}(\theta + \beta) + \beta \right] = \left( \frac{R}{r} + 1 \right) \sin \beta,$$

which one can also write

$$(6) \quad \sin \left[ \frac{R}{r} \theta + \left( \frac{R}{r} + 1 \right) \beta \right] = \left( \frac{R}{r} + 1 \right) \sin \beta.$$

**256.** The calculation of the equations (5) and (6) is complicated; one sees, in fact, that one can only proceed by successive approximations. We give below an example of this kind of calculation.

**257. Numerical Application.** To find the value of the angle  $\alpha$  (Fig. 70) corresponding to the position of the point  $M$  in the epicycloid of the tooth of a wheel with 60 teeth gearing in a pinion with 6 leaves.

We will suppose that the point  $M$  considered belongs to the point of the tooth; it is, therefore, the extreme point of the curve of this tooth.

The application of the formula (5) gives us, first,

$$\frac{R}{r} + 1 = \frac{60}{3} + 1 = 21; \quad \frac{r}{R} = \frac{3}{60} = 0.05.$$

Moreover,

$$\theta = \frac{360^\circ}{4 \times 60} = 1^\circ 30',$$

since half of a tooth should take up a quarter of the pitch of the gearing.



Let us suppose, first, the angle  $\alpha = 80^\circ$ ; we would then have

$$\beta = \frac{r}{R} \alpha - \theta = 4^\circ - 1^\circ 30' = 2^\circ 30'.$$

The calculation gives

$$\begin{array}{r} \frac{R}{r} + 1 = 21 \quad \log : \frac{R}{r} + 1 - \cos \alpha = 1.31861 \\ - \cos 80^\circ = \underline{0.17365} \quad + \log : \text{tang} : \beta = \underline{8.64009} \\ \frac{R}{r} + 1 - \cos \alpha = 20.82635 \quad \quad \quad 9.95870 \end{array}$$

The logarithm of the second member of the equation (5) is, therefore, 9.95870; in order that equality may exist between the first and second members, it would be necessary for the above logarithm to be equal to that of  $\sin \alpha = \sin 80^\circ$ . We have

$$\begin{array}{r} \log : \text{second member} = 9.95870 \\ \log : \sin : 80^\circ = \underline{9.99335} \\ \text{difference} = 0.03465 \end{array}$$

The equality of the two members of the equation (5) is not verified; the logarithm of  $\sin \alpha$  is too great by 0.03465; it is consequently necessary that the value of  $\alpha$  be greater than  $80^\circ$ . Let us try to take  $\alpha = 86^\circ$ . We will have

$$\begin{array}{r} \beta = \frac{r}{R} \alpha - \theta = 2^\circ 48'. \\ \frac{R}{r} + 1 = 21 \quad \log : \frac{R}{r} + 1 - \cos. \alpha = 1.32077 \\ - \cos : 86^\circ = \underline{0.06976} \quad \log : \text{tan} : \beta = \underline{8.68938} \\ \quad \quad \quad 20.93024 \quad \quad \quad 10.01015 \\ \quad \quad \quad \quad \quad \quad \log : \sin \alpha = \log \sin 86^\circ \quad \underline{9.99894} \\ \quad \quad \quad \quad \quad \quad \text{Difference,} \quad .01121 \end{array}$$

This time, the logarithm of the first member is smaller than that of the second, which indicates that the angle of  $86^\circ$  is too great. The angle  $\alpha$  should, therefore, be found between 80 and 86 degrees.

Let us now establish the following proportion, taking note that for  $6^\circ$  of arc the difference between the natural values of the cosines is 0.04586 :

$$\frac{0.04586}{0.01121} = \frac{6}{x} \text{ from whence } x = \frac{6 \times 1121}{4586},$$

on making the calculation

$$x = 1.^\circ 4666 \dots = 1^\circ 28'.$$

Thus, if the difference which one obtains by the calculation of the two members were proportionate to the difference of the angles





**THIS PAGE IS LOCKED TO FREE MEMBERS**

Purchase full membership to immediately unlock this page

# HISTORY

Tens of thousands of important historical sources, many previously unobtainable, are now available for the first time with a Forgotten Books Full Membership.

Unlimited Access  
\$8.99/month

**Continue**

\*Fair usage policy applies









The equation (5) can be written under the following form, remarking, however, that the primitive radii are proportionate to the number of teeth and that, in this formula, the radius  $r$  of the generating circle is equal to half of the primitive radius of the pinion.

$$\sin \alpha = \left( \frac{n}{\frac{1}{2} n^1} + 1 - \cos. \alpha \right) \text{tang.} \left( \frac{\frac{1}{2} n^1}{n} \alpha - \theta \right).$$

When in a given gearing one finds through the calculation of the above equation, the angle

$$\frac{1}{2} \alpha > \frac{360^\circ}{n'},$$

the tooth of the wheel may drive the pinion leaf a sufficient quantity after the line of center, so that the contact of the following tooth may commence on this line. Such is, for example, the case of a wheel with 96 teeth gearing in a pinion of 12 leaves.

We have, in fact, in this case,

$$\alpha = 65^\circ 6' \text{ and } \frac{1}{2} \alpha = 32^\circ 33'.$$

The tooth can, therefore, drive the leaf an angle of  $32^\circ 33'$ . On the other hand, we see that the angle which separates two consecutive flanks is

$$\frac{360^\circ}{12} = 30^\circ.$$

Consequently, one can prove that the tooth drives the leaf  $2^\circ 33'$  farther than is absolutely necessary.

On the contrary, for the gearing of a 60-tooth wheel in a 6-leaf pinion, one has  $\alpha = 84^\circ 31' 34''$ , from whence  $\frac{1}{2} \alpha = 42^\circ 15' 47''$ .

Moreover,

$$\frac{360^\circ}{6} = 60^\circ.$$

Since the leaf should be driven by the tooth an angle of  $60^\circ$  and it is driven in reality only an angle of  $42^\circ 15' 47''$  after the line of centers, the contact must necessarily commence  $17^\circ 44' 13''$  before this line, since  $42^\circ 15' 47'' + 17^\circ 44' 13'' = 60^\circ$ .

The gearing should be arranged, in this case, in such a manner that the tooth enters into contact with the leaf before the line of centers, and we have seen that, for this purpose, the leaf of the pinion must be terminated with an epicycloidal form susceptible of being driven by the flank of the tooth up to the moment when the contact is made on the line of centers; starting from this point, it is the curve of the tooth which drives the flank of the leaf (225).



The epicycloid of the leaf should be described by a point of a generating circumference whose diameter is equal to the primitive radius of the wheel.

**260.** Since the angle at which the tooth should enter into contact with the leaf before the line of centers is never very considerable, it is very rarely necessary that the excess of the tooth be perfectly ogival. This shape would be, moreover, rather hurtful than useful, because the friction would be increased and it would also necessitate longer teeth for the wheel, in order to allow the free introduction of the pinion leaf in the space which separates two teeth of the wheel.

One preserves, therefore, only that part of the epicycloid which is directly useful. In large mechanics, one simply removes the desired quantity from the points of the teeth.\*

In horology, one terminates the pinion leaf by a rounded form, an arc of an ellipse, for example. This shape of the excess should be determined in such a manner that its radius of curvature at the point of connection with the curve of the epicycloid, should be the same for the two lines (Fig. 71). It is evident that, for security, one makes the contact of the tooth and the leaf commence some degrees sooner than is necessary. Thus, in the preceding case, one will admit a contact commencing  $20^\circ$  before the line of centers, rather than  $17^\circ 44' 13''$ .

**261.** Practically, in a great number of ordinary pinions, one finds the excess of the leaf terminated by a half circle. We are really in a position to recognize that this form is defective, especially for pinions of low numbers. It is easy to prove that with this shape, the tooth drives the leaf too far after the line of centers, that the point of contact does not rest on the circumference of the generating circle and that there can be established, before the line of centers, a contact of the flank of a tooth with the rounded part of the leaf. There results from this last act a butting often very pronounced.

It is probably this butting observed by horologists, which frequently makes them exaggerate the importance of the friction of the gearings before the line of centers and which has made them believe that this last is much more considerable than that which is produced after this line. The friction observed should only be in reality the butting, and it suffices to suppress this to per-

\*This operation is called the chamfering of the teeth.





**THIS PAGE IS LOCKED TO FREE MEMBERS**

Purchase full membership to immediately unlock this page

# DELVE INTO FANTASY, MAGIC, MYTHOLOGY & FOLKLORE

Forgotten Books'  
Full Membership gives  
access to 797,885 ancient  
and modern, fiction and  
non-fiction books.

**Continue**

\*Fair usage policy applies



a circle with diameter equal to the primitive radius of the wheel, the formula (248)

$$\delta = r' \left( 1 + \frac{r}{r + r'} \right) \sin \frac{1}{2} \alpha$$

should be written here

$$\delta = r \left( 1 + \frac{r'}{r + r'} \right) \sin \frac{1}{2} \alpha.$$

Admitting

$$r = 60, r' = 6 \text{ consequently } \frac{1}{2} \alpha = \frac{20^\circ}{6} = 2^\circ,$$

we would then have

$$\delta = 60 \left( 1 + \frac{6}{66} \right) \sin 2^\circ = 65.454 \times \sin 2^\circ$$

and, making the calculation

$$\delta = 2.28433.$$

**264.** Let us now seek the value of the angle  $w$ , formed by the radius of curvature and the straight line passing through the middle of the leaf (Fig. 71).

The angle  $a c O$  is a right angle and we have, therefore,

$$a c O = 90^\circ.$$

The angle  $a O c$ , or  $\frac{1}{2} \alpha$ , is  $2^\circ$ ,

$$a O c = 2^\circ;$$

it follows that

$$c a O = 88^\circ$$

and

$$O' a c = 180^\circ - 88^\circ = 92^\circ.$$

We have, moreover, the angle

$$a O' d = 20^\circ - \frac{360^\circ}{2 \times 3 \times 6} = 10^\circ,$$

since in this case the width of one leaf is equal to one-third of the pitch of the gearing (231).

We will have at length

$$\begin{aligned} w = c d s = O' d a &= 180^\circ - O' a c - a O' d \\ w &= 180^\circ - (92^\circ + 10^\circ) \\ w &= 78^\circ. \end{aligned}$$

**265.** We have afterward to determine the straight line  $O' c$ , joining the center of the pinion to the first point of contact.

In the triangle  $G c O'$  we know the sides

$$G O' = \frac{1}{2} r + r'$$

$$G c = \frac{1}{2} r$$

and the angle

$$O' G c = 4^\circ.$$



We will have, consequently, the value of the angle  $a O' c$  expressed by

$$\text{tang} : a O' c = \frac{\frac{1}{2} r \sin 4^\circ}{\frac{1}{2} r + r' - \frac{1}{2} r \cos 4^\circ}$$

or

$$\text{tang} : a O' c = \frac{\sin 4^\circ}{1 + \frac{r'}{\frac{1}{2} r} - \cos 4^\circ}.$$

The calculation gives

$$a O' c = 19^\circ 0' 46''.$$

The side  $O' c$  of the triangle  $O' c G$  will be at last given us by the formula

$$O' c = \frac{\frac{1}{2} r \cdot \sin 4^\circ}{\sin a O' c},$$

from whence, after making the calculation,

$$O' c = 6.4236.$$

**266.** Let us further project the point  $c$  on  $e$ , on the straight line  $O' s$ , designating by  $y$  the right line  $c e$  and let us determine this line. We will have

$$y = O' c \sin c O' d,$$

but

$$c O' d = a O' c - a O' d = 19^\circ 0' 46'' - 10^\circ = 9^\circ 0' 46'';$$

therefore,

$$y = 6.4236 \times \sin 9^\circ 0' 46''$$

and

$$y = 1.00626.$$

**267.** We now know the radius of curvature  $\delta$  at the point  $c$  of the epicycloid, the inclination of this radius to the line passing through the middle of the leaf, therefore the angle  $w$  and, finally, the ordinate  $y$  corresponding to this same data. There only remains, now, to determine an elliptical curve capable of satisfying these conditions.

**268. Radius of Curvature of an Ellipse.** The equation of this curve being

$$a^2 y^2 + b^2 x^2 = a^2 b^2,$$

one obtains

$$\frac{d y}{d x} = - \frac{b^2 x}{a^2 y}$$

and

$$\frac{d^2 y}{d x^2} = - \frac{b^4}{a^2 y^2}.$$

The general equation of the radius being

$$\delta = \frac{\left( 1 + \frac{d y^2}{d x^2} \right)^{\frac{3}{2}}}{\frac{d^2 y}{d x^2}},$$



we will obtain successively

$$\delta = \frac{\left(1 + \frac{b^4 x^2}{a^4 y^2}\right)^{\frac{3}{2}}}{-\frac{b^4}{a^2 y^3}} = \frac{(a^4 y^2 + b^4 x^2)^{\frac{3}{2}}}{- \frac{(a^2 y^3)^{\frac{3}{2}}}{a^2 y^3} b^4}$$

$$(a^4 y^2)^{\frac{3}{2}} = (a^2 y)^3 = a^6 y^3,$$

therefore

$$\frac{(a^4 y^2)^{\frac{3}{2}}}{a^2 y^3} = \frac{a^6 y^3}{a^2 y^3} = a^4;$$

consequently

$$\delta = - \frac{(a^4 y^2 + b^4 x^2)^{\frac{3}{2}}}{a^4 b^4}.$$

We have the length of the normal  $MN$  (Fig. 72) expressed by

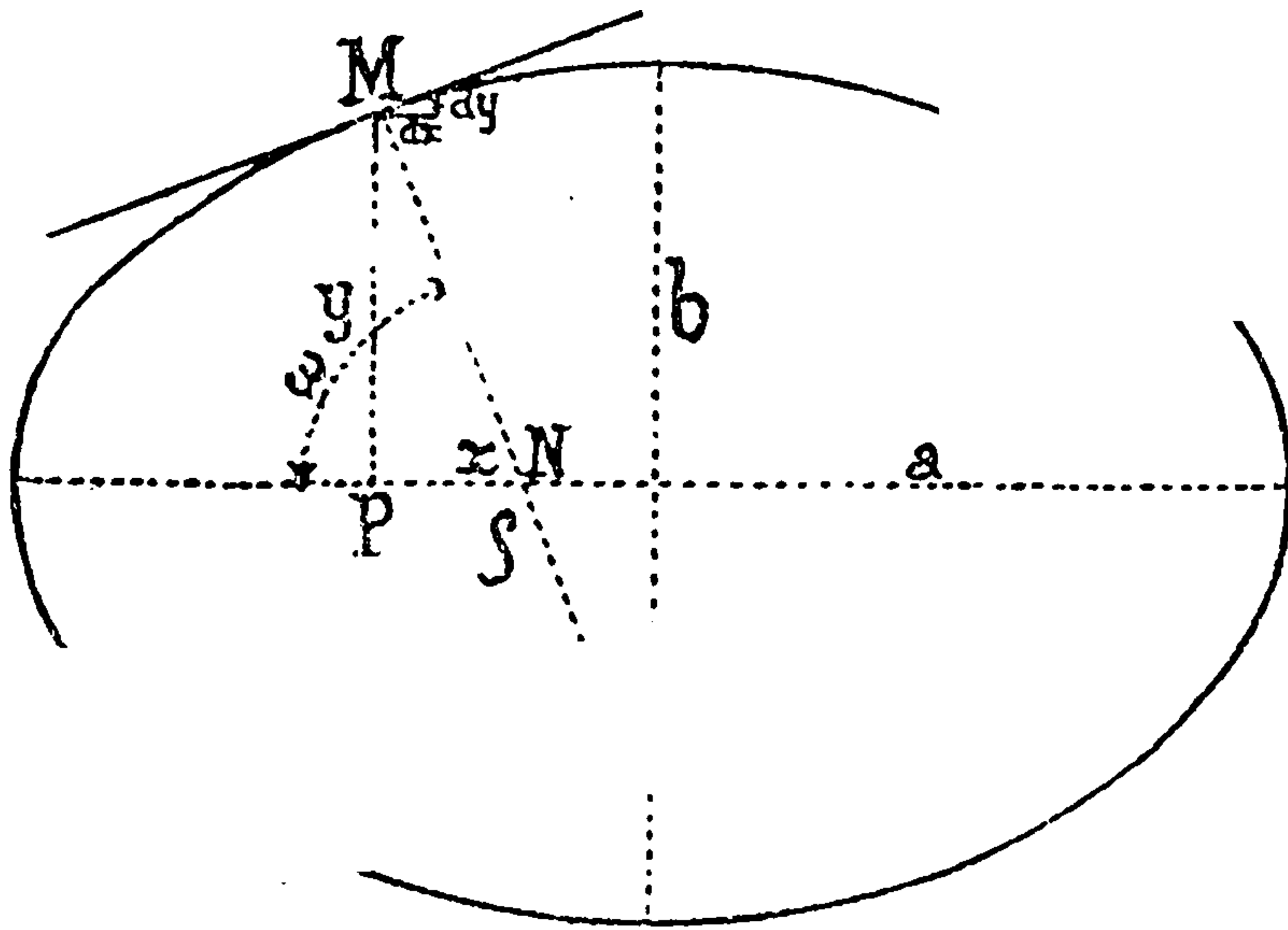

Fig. 72

and

$$y \sqrt{1 + \left(\frac{dy}{dx}\right)^2} = y \sqrt{1 + \frac{b^4 x^2}{a^4 y^2}}$$

$$y \sqrt{a^4 y^2 + b^4 x^2} \frac{1}{a^2 y} = MN$$

$$MN = \frac{\sqrt{a^4 y^2 + b^4 x^2}}{a^2}$$

$$MN^3 = \frac{(a^4 y^2 + b^4 x^2)^{\frac{3}{2}}}{a^6}.$$

One can, therefore, place

$$\delta = \frac{a^2 MN^3}{b^4};$$

we have, on the other hand,

$$MN = \frac{y}{\sin w},$$

therefore

$$\delta = \frac{a^2 y^3}{b^4 \sin^3 w},$$





**THIS PAGE IS LOCKED TO FREE MEMBERS**

Purchase full membership to immediately unlock this page



# HISTORY

Tens of thousands of important historical sources, many previously unobtainable, are now available for the first time with a Forgotten Books Full Membership.

Unlimited Access  
\$8.99/month

**Continue**

\*Fair usage policy applies



**270. Total Radius of the Pinion.** The total length of the pinion leaf is composed of the sum of the two lengths  $O' e$  and  $e p$  (Fig. 71).

The distance  $e p$  is equal to  $a - x$  (Fig. 72). We have

$$- x = \frac{a^2 y}{b^2 \text{tang } w};$$

in figures

$$- x = \frac{1.62245^2 \times 1.00626}{1.05834^2 \times \text{tang } 78^\circ} = 0.50266,$$

and

$$a - x = 1.62245 - 0.50266 = 1.11979.$$

On the other hand, we have (Fig. 71)

$$O' e = O' c \cdot \cos c O' e,$$

we know (265)

$$O' c = 6.4236$$

and the angle (266)

$$c O' e = 9^\circ 0' 46'';$$

therefore

$$O' e = 6.4236 \cdot \cos 9^\circ 0' 46'' = 6.3444.$$

The total radius of the pinion will be

$$\begin{array}{r} O' e = 6.3444 \\ + (a - x) = 1.1198 \\ \hline R' = 7.4642. \end{array}$$

**271. NOTE.**—If the excess of the above pinion leaf was formed by a semi-circumference, we would obtain its total radius in a much more simple manner.

The primitive radius being 6, the length of the circumference is as follows : primitive circumference =  $2 \pi \times 6$ .

The pitch of the gearing should be equal in length to  $2 \pi$ , since the number of leaves is 6. The width of a leaf, reckoned on the circumference, is one-third of the pitch, therefore

$$\text{width of a leaf} = \frac{2 \pi}{3};$$

finally, the height of the excess is half of this last value, therefore

$$\text{excess} = \frac{\pi}{3}.$$

We will have, consequently, the total radius,

$$R' = r' + \frac{\pi}{3} = 6 + 1.0472 = 7.0472$$

or

$$R' = 7.05$$

in round numbers.



## Graphical Construction of Gearings.

272. Let us suppose that we know the distance between the centers  $D$ , also the numbers of teeth of the two mobiles, and let these be, for example,  $D = 240$  mm.;  $n = 70$  teeth and  $n' = 7$  leaves.

The formulas (185)

$$r = D \frac{n}{n + n'} \text{ and } r' = D \frac{n'}{n + n'},$$

give us the value of the primitive radii of the two wheels

$$r = 240 \frac{70}{70 + 7} \text{ and } r' = 240 \frac{7}{70 + 7};$$

the calculations made, one obtains

$$r = 218.18 \dots \text{ and } r' = 21.818 \dots$$

From the centers  $O$  and  $O'$  (Plate I), previously determined, one describes the two primitive circles calculated, tangent at the point  $a$

Let us suppose that we wish to construct a flank gearing, one can commence by determining the shape of the tooth. Describe, for this purpose, the generating circle  $O''$  with radius equal to half that of the primitive circle of the pinion, and by its rolling around the primitive circle of the wheel, let us make it describe the epicycloid  $AB$ .

Let us remark that for the clearness of the plan, instead of putting the origin of the curve on the line of centers, as would be the logical way to do, we have carried this construction back to another point, which, practically, amounts to the same thing.

In order to construct the epicycloid, one can follow the method we have indicated (242), or proceed more simply by carrying back on several successive positions of the generating circle, such as 1, 2, 3, . . . , certain lengths  $I_1 I = I_1 O$ ,  $2_1 II = OI_1 + I_1 2_1$ ,  $3_1 III = OI_1 + I_1 2_1 + 2_1 3_1$ , etc. On connecting the points I, II, III, . . . by a continuous curve, one obtains the epicycloid of the tooth.

This method, which is not exactly correct, since it substitutes the lengths of chords for the lengths of arcs, is, however, admissible for drawings in which the successive positions of the generating circle are relatively close together.

We divide, afterwards, one of the primitive circumferences, that of the pinion, for example, into as many parts as that wheel



should have teeth. We can commence this division at any point of the circumference, but generally it is commenced on the line of centers, or at the point where the leaf of the pinion should be found at the moment of the last contact with the tooth.

In order to determine this last position, one can make use of the table (257), which gives us, for the gearings most generally used in horology, the angle of driving of the leaf by the tooth after the line of centers. Thus, for the gearings of a wheel of 70 teeth with a pinion of 7 leaves, we see that the tooth drives the leaf  $39^{\circ} 55' 15''$  after the line of centers.

If one wishes to determine this position, graphically correct, a previous division of the primitive circle of the pinion gives the "pitch of the gearing." One lays off this length from the origin of the curve  $A$ , to  $C$ ; one divides the pitch into two equal parts, one of which should be occupied by the whole of the tooth, the other by the space (231). The extremity  $D$  of the ogive of the tooth will be determined by drawing the prolonged radius  $OD$  passing through the middle of the tooth. From the center  $O$ , one describes an arc of a circle passing through the point  $D$  and one thus obtains the point  $d$ , extreme position of the contact of the tooth with the leaf (223). One draws, afterwards, the straight line  $O'd$  prolonged to the primitive circumference of the pinion. The point  $i$  is then the point of departure for the definite division of the pinion. If one has proceeded with exactitude, the angle  $a O'i$  should be, in this case, equal to  $39^{\circ} 55' 15''$ . One can thus prove that the first contact of the tooth with the leaf should take place before the line of centers and at an angular distance from this line of at least  $11^{\circ} 30' 27''$ .

The excess of the leaf should be formed with an epicycloidal arc, as we have already indicated (259). This epicycloid is that which is described by a point of a circumference with radius equal to half the primitive radius of the wheel.

The curves of the teeth being thus formed and their positions determined, it becomes easy to construct the gearing, by remarking that for the gearings of watch trains, the leaf of the pinion occupies the third of the pitch for pinions of 10 leaves and less, and two-fifths for those of 12 leaves and more (231).

One then limits the epicycloid of the leaf, according to what we have said, by conserving to it only a length sufficient for the driving to commence a little before the point where the first theoretical





**THIS PAGE IS LOCKED TO FREE MEMBERS**

Purchase full membership to immediately unlock this page

# DELVE INTO FANTASY, MAGIC, MYTHOLOGY & FOLKLORE

Forgotten Books'  
Full Membership gives  
access to 797,885 ancient  
and modern, fiction and  
non-fiction books.

**Continue**

\*Fair usage policy applies



contact should be effected, normally. During a very short instant, two consecutive teeth are thus simultaneously in contact, and this fact suffices to insure the correct action of the gearing.

The leaf is afterwards terminated by an arc of an ellipse whose radius of curvature at the junction of the two curves is the same as that of the epicycloid determined.

One then limits the length of the flanks of the leaves and teeth by arcs of circles with radius sufficient to allow not only the free introduction of the teeth and the leaves in the corresponding spaces, but also reserving the place which foreign bodies would occupy, dust and other matters which are invariably introduced, with time, into the sets of teeth.

The gearing is thus constructed and having made the drawing on a sufficiently enlarged scale, one could deduce from it all the relative dimensions for its practical construction, as we will see later on.

**273.\*** Plate II represents the same drawing to a still more greatly enlarged scale; the distance of the centers is 2200 mm., the primitive radius of the wheel 2 meters and that of the pinion 200 mm. This design allows us to show more clearly the manner in which the contact of the tooth with the leaf is effected before the line of centers; the shape of the leaf, represented in dotted lines, is semi-circular; one sees thus that in this case the normal at the point of contact does not pass through the point of tangency of the primitive circumferences, as is the case for the semi-elliptical shape, and consequently the force transmitted has not the value which we determined (195 and the following)

$$F' = F \frac{n'}{n}$$

and that there should be produced a "butting."

**274.** The drawing of gearings of ratchet wheels, setting wheels and dial wheels, etc., is executed in an analogous manner; we will examine later on the several modifications admitted for such wheel teeth. In this construction there must also be taken into consideration the manner in which the "play" is distributed (232, 233).

#### **Practical Application of the Theory of Gearings.**

**275.** In practice there are presented problems of different natures in which it is desired to determine the relative dimensions of wheels and pinions.

---

\*As Plate II has, for lack of space, been reduced one-half, the distance of the centers is 1100 mm.; the primitive radius of the wheel, 1 m., and that of the pinion 100 mm.



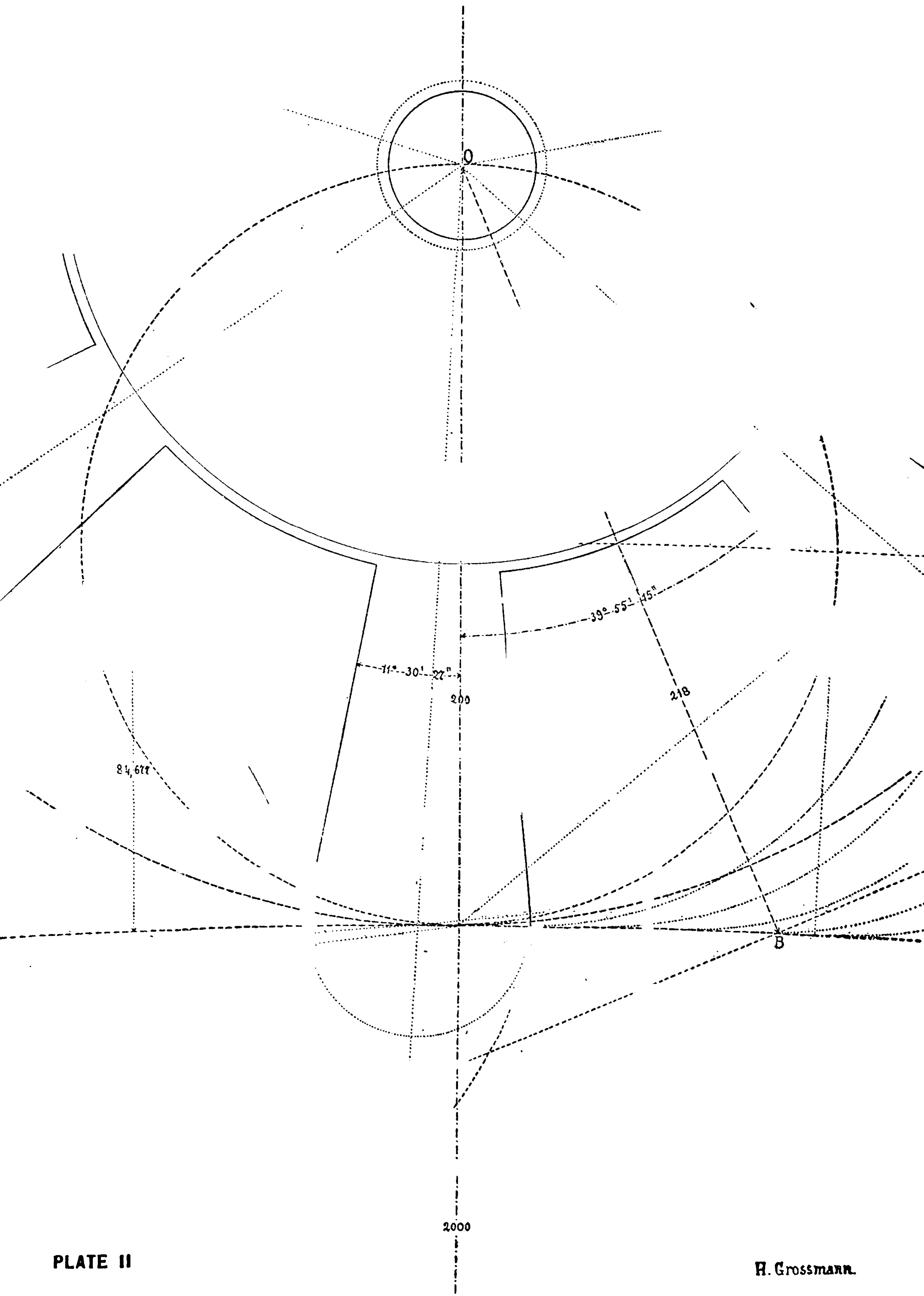



It is evident that, at first sight, the use of a suitable instrument to establish these sizes becomes very important to the workman, for the reason that it saves him all calculation. We will cite the one which is the most exact and at the same time the most simple to use.

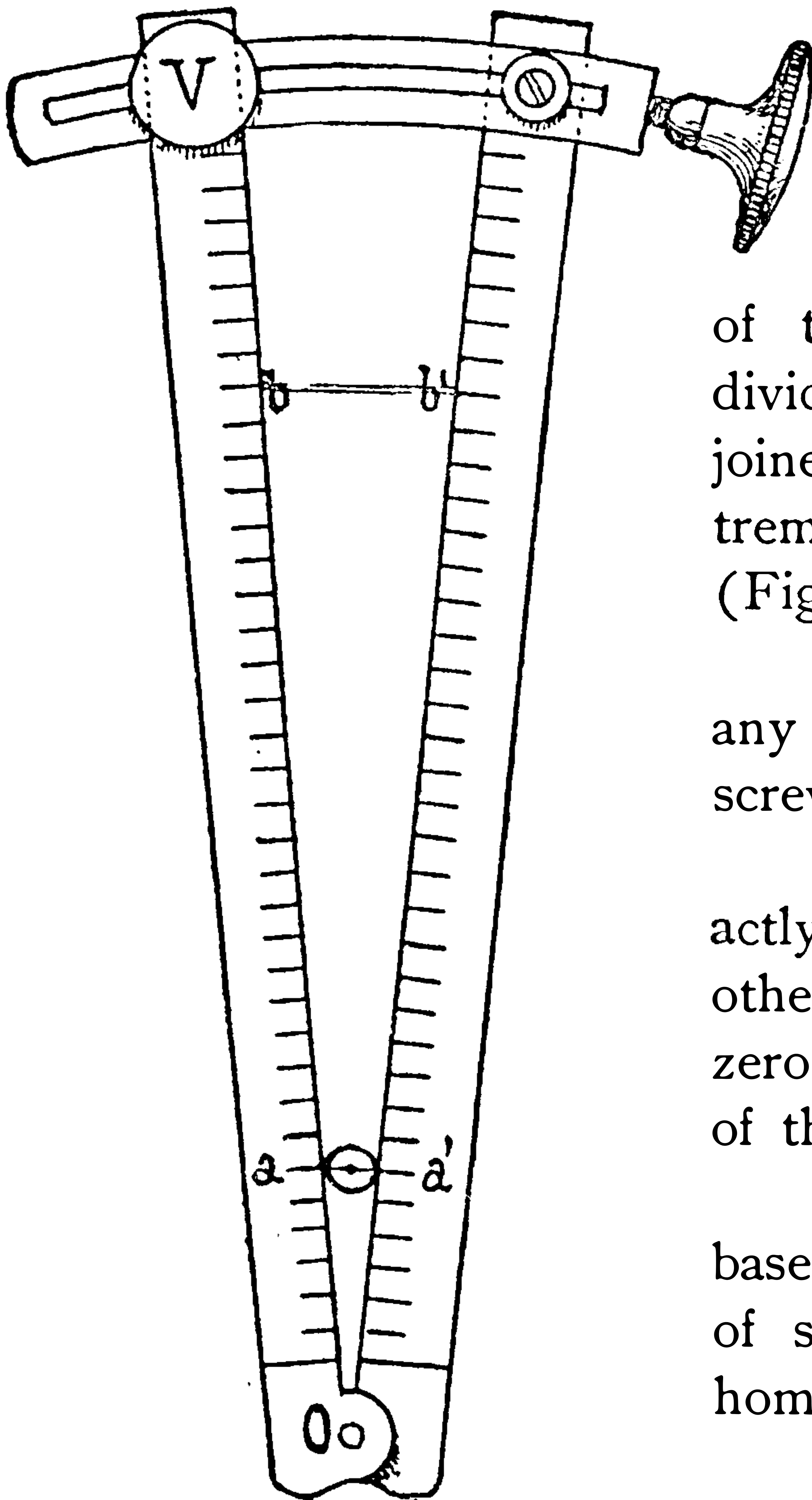

Fig. 73

### 276. The Proportional Compass and its Use.

The proportional compass, in its most rational arrangement, is formed of two rule plates, straight, and divided into equal parts; they are joined together at one of their extremities by means of a hinge  $O$  (Fig. 73).

These rules can be fastened in any position by means of a clamping screw  $V$ .

Their divisions should be exactly corresponding, equal to each other and numbered. The point zero is found at the hinge, summit of the angle  $b O b'$ .

The proportional compass is based on the fundamental principle of similar triangles, in which the homologous sides are proportional.

Thus, imagining the primitive diameters of a wheel placed at the division of the compass corresponding to its number of teeth and the primitive diameter of the pinion at the division corresponding to its number of leaves, one should have the proportion

$$\frac{b b'}{a a'} = \frac{o b}{o a}.$$

Since, in a gearing the number of teeth of the mobiles should be to each other as their radii, or their primitive diameters, one understands that to determine the primitive diameter of a pinion, knowing that of the wheel, it suffices to place the latter at the division corresponding to its number of teeth and, for this purpose, to open the two arms of the compass the proper distance. The





**THIS PAGE IS LOCKED TO FREE MEMBERS**

Purchase full membership to immediately unlock this page

# HISTORY

Tens of thousands of important historical sources, many previously unobtainable, are now available for the first time with a Forgotten Books Full Membership.

Unlimited Access  
\$8.99/month

**Continue**

\*Fair usage policy applies





Let us describe the epicycloid of the tooth by making a generating circle with radius equal to half the primitive radius of the pinion, roll around the primitive circle of the wheel;  $r'$  being the radius of the pinion. One will have

$$\frac{1}{2} r' = \frac{6 \times 54^{\circ}}{60 \times 2} = 27.$$

Let us now calculate the length of the chord  $c$ , which subtends the half of the arc occupied by one tooth. We have the formula

$$c = 2 r \sin \frac{1}{2} \alpha$$

and

$$\alpha = \frac{360^{\circ}}{4 \times 60} = 1^{\circ} 30'.$$

One will have, therefore,

$$c = 2 \times 540 \times \sin 0^{\circ} 45'$$

$$\log : 1080 = 3.0334238$$

$$\log \sin 0^{\circ} 45' = 8.1169262$$

$$\log : (1080 \sin 0^{\circ} 45') = \underline{1.1503500}$$

Consequently, one will have

$$\text{Chord of one-quarter of the pitch} = 14.1367 \text{ mm.}^*$$

Let us lay off this length of  $t$  on  $a$  (Fig. 75) and draw the radius  $o a$  prolonged to the point  $b$  belonging to the epicycloid of the tooth;  $o b$  is then the total radius of the wheel and  $a b$  the height of the ogive of the tooth.

On measuring  $a b$ , we will find it equal to 25 mm. and we will have the total radius of the wheel expressed in units of diametrical pitch, by the sum

$$60 + \frac{2 \times 25}{18} = 60 + 2.77 = 62.77.$$

One will place, therefore, the total diameter of the wheel at the division 62.77 of the compass, so that its primitive radius corresponds to the division 60.

**279.** One could proceed in an analogous manner for the pinion. Let us remark, however, that while the height of the ogive of the wheel is fixed, since it is formed by an epicycloid described by a point of a generating circumference with given radius, the excess of the pinion leaf is not so easily determined.

\* One could have obtained this result without the aid of trigonometry, by noting that the arcs and chords of small angles differ very little from each other.

One would thus have

$$\frac{2 \pi r}{4 \times 60} = 4.5 \times 3.1416 = 14.1372,$$

a very close approximation.



The form of the excess which one finds in a very great number of pinions is that of a semi-circumference with radius equal to half the breadth of a leaf measured on the primitive circumference. This form, although we know it to be bad, especially for pinions of low numbers, offers, however, a ready means for the calculation.

Suppose  $n'$  to be the number of leaves in the pinion.

The primitive diameter expressed in function of the diametrical pitch will be likewise  $n'$ , since it is divided into as many equal parts as the pinion has leaves.

The primitive circumference is, therefore,

$$\text{circumference} = \pi n'$$

and the pitch of the gearing

$$\frac{\pi n'}{n'} = \pi.$$

If this pitch comprises a third for the full tooth and two-thirds for the space, the length of the arc corresponding to the thickness of one leaf being double the radius  $\delta$  of the circle of the excess, one will have

$$\delta = \frac{\pi}{2 \times 3}.$$

There must, therefore, be added a value equal to  $\delta$  to the two extremities of the primitive diameter of the pinion expressed in units of diametrical pitch :

$$\text{Total radius} = n' + \frac{\pi}{3} = n' + 1.05.$$

Thus, for the pinions whose full part of the pitch is equal to half of the space and whose excess has the form of a semi-circle, the total diameter should be stopped at the division corresponding to the number of leaves increased by 1.05.

For the gearing which we will consider, of a wheel with 60 teeth and a pinion of 6 leaves, one should place the wheel at the division 62.77 and the pinion at the division 7.05.

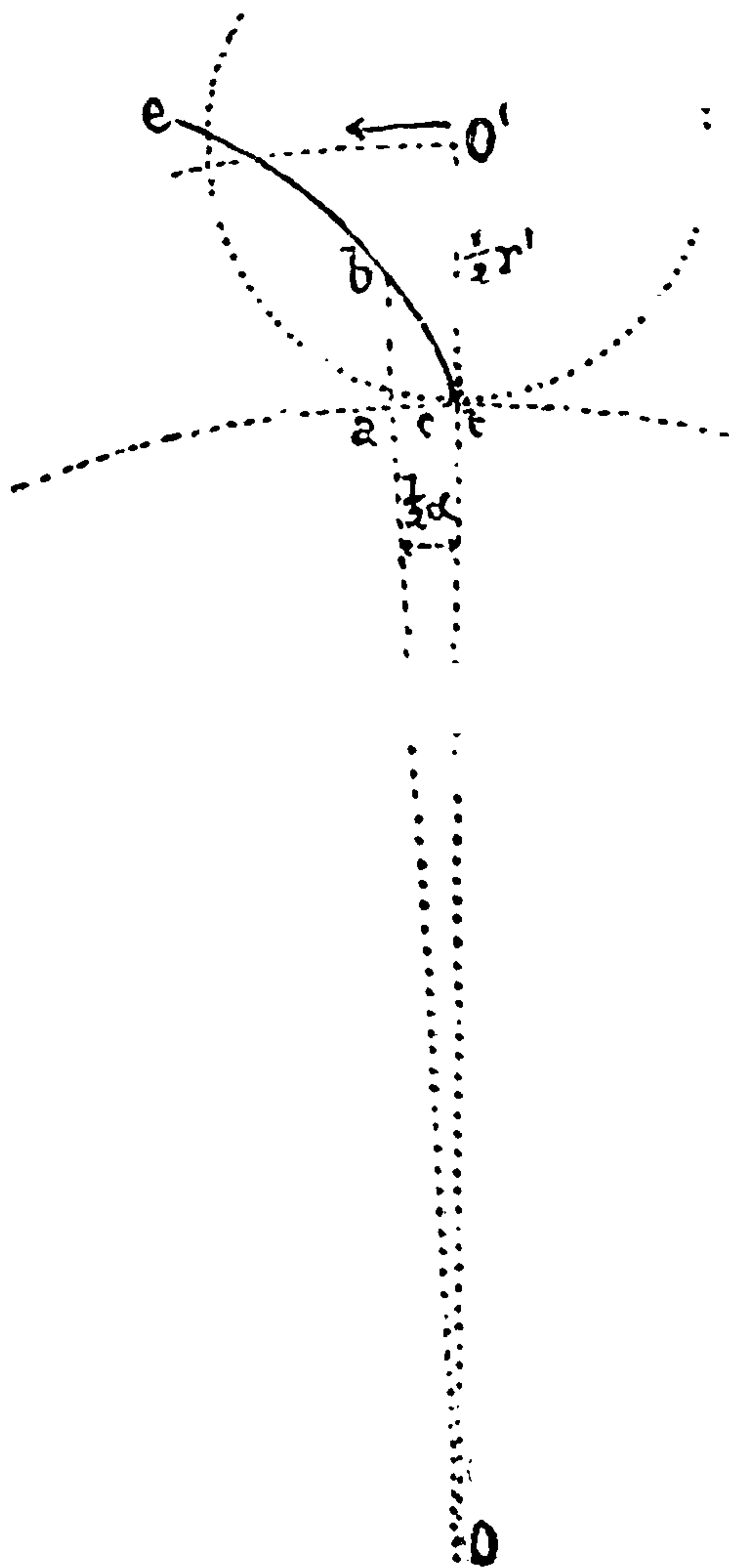

Fig. 75



**280.** Let us again make the calculation for a pinion in which the leaf is two-fifths of the pitch (12 leaves and above).

As in the preceding case, the pitch of the gearing is equal to  $\pi$  and the radius of the ogive  $\delta = \frac{\pi}{5}$ ;

as  $2 \delta$  must be added to the primitive diameter, we will have

$$2 \delta = \frac{2 \pi}{5} = 1.25.$$

The total diameter expressed in units of diametrical pitch is, therefore,

$$n' + 1.25.$$

**281.** In the case of pinions with the excess semi-elliptical, the height of this excess becomes superior to those with which the preceding calculations have furnished us.

We have seen that the calculation of this value is complicated (259 and the succeeding); therefore, without entering into other details, we refer, for these values, to the table which we give further on (283, third column).

Thus, taking up again our gearing of a 60-tooth wheel and 6-leaf pinion, we find in this table, that the total diameter of the pinion expressed in units of diametrical pitch is 7.4648; that is to say, 7.5 in round numbers.

**282.** Practically, to employ in a proper manner the proportional compass, one must, therefore, commence by examining the excess of the pinion leaves, estimating it with relation to the breadth of the leaf.

If one judges, for example, that it is equal to half the thickness of the leaf, one will add a unit to the number of leaves  $n'$ ; if the excess appears to be three-quarters of the thickness, one will add 1.5 and, finally, if the height is judged equal to twice the thickness of the leaf, one will add 2.

A compound microscope, the eyeglass provided with spider lines and mounted on its lower side on a carriage furnished with a micrometer screw, allowing the object observed to move in the field of the instrument, can measure with great precision the height of the ogives of the wheels or of the excess of pinions. In default of this instrument, the method which we have just indicated is exact enough to be used.

**283.** The table which we give hereafter indicates the number of the division on the compass for the gearings most used in horology. Thus, on placing an 80-tooth wheel at the division





**THIS PAGE IS LOCKED TO FREE MEMBERS**

Purchase full membership to immediately unlock this page

# DELVE INTO FANTASY, MAGIC, MYTHOLOGY & FOLKLORE

Forgotten Books'  
Full Membership gives  
access to 797,885 ancient  
and modern, fiction and  
non-fiction books.

**Continue**

\*Fair usage policy applies



83.38 of the compass, a 10-leaf pinion in which it should gear should correspond to the division 11.5 if the excess is of semi-elliptical shape, or at the division 11.05 if this form is semi-circular.

For a pinion with the uneven number of 7 leaves, one will find two indications in the table, one giving the real diameter, the other permitting the placing of the pinion with one leaf pressing against an arm of the compass, and the two leaves opposite against the other arm. This last measure comprises, therefore, in units of diametrical pitch, a total radius increased by the versed sine  $OB$  (Plate II).

After what we have said, it will be easy to obtain in a graphical manner the figures corresponding to gearings not appearing in the table.

**284. Verification of a Proportional Compass.** The two divided scales should be perfectly straight and consequently in exact juxtaposition when the instrument is closed; this, one verifies by holding the instrument to the height of the eyes and seeing if the two scales are perfectly fitted against each other.

The divisions should be regular and the zero point should be found in the center of the hinge.

It is also easy to verify this condition with exactitude by taking off, with a pair of sharp-pointed dividers, a certain number of divisions, 10, for example: on moving, then, these dividers over the whole of the part divided, it is easy to assure oneself of the exactness of this condition. Finally, on placing one of the points of the dividers on the division 10, one should be able to place the other on the center of the hinge.

This hinge should be made in such a manner that the arms can be spread without any jerk, that is to say, with even friction; in no case could any play or shake whatever be allowed at this hinge.

A compass being thus verified, it could be used with the aid of the given table.

There exist other systems of proportional compasses, most of which dispense with the use of an accessory table. Let us remark, however, that the one which we have just described has its principle founded on an exact and rational basis and that the table which it requires complicates its use very little, if at all.

**285. Determination of the Distance Between the Centers of a Gearing by Means of the Proportional Compass and of a Depthing Tool.** Having fastened the proportional compass in such a manner



that the primitive radius of the wheel corresponds to the figure for its number of teeth, one measures, in this same opening, the diameter of one of the arms of a depthing tool. Let  $d$  be the division corresponding to this last measure. One opens, then, the depthing tool until the two arms  $a$  and  $b$ , drawn in section (Fig. 76), correspond to the division

$$\frac{n + n'}{2} + d.$$

This opening then gives the distance between centers.

Example: Having regulated the opening in the proportional compass so that the total diameter of a 60-tooth wheel is fitted to the division 62.78 (see the table), one measures the arm of a depthing tool and finds that its diameter corresponds to the division 8; we will thus have

$$\frac{60 + 6}{2} + 8 = 41,$$

the pinion having 6 leaves. The opening of the depthing tool should then be regulated in such a manner that the two arms  $a$  and  $b$  correspond to the division 41.

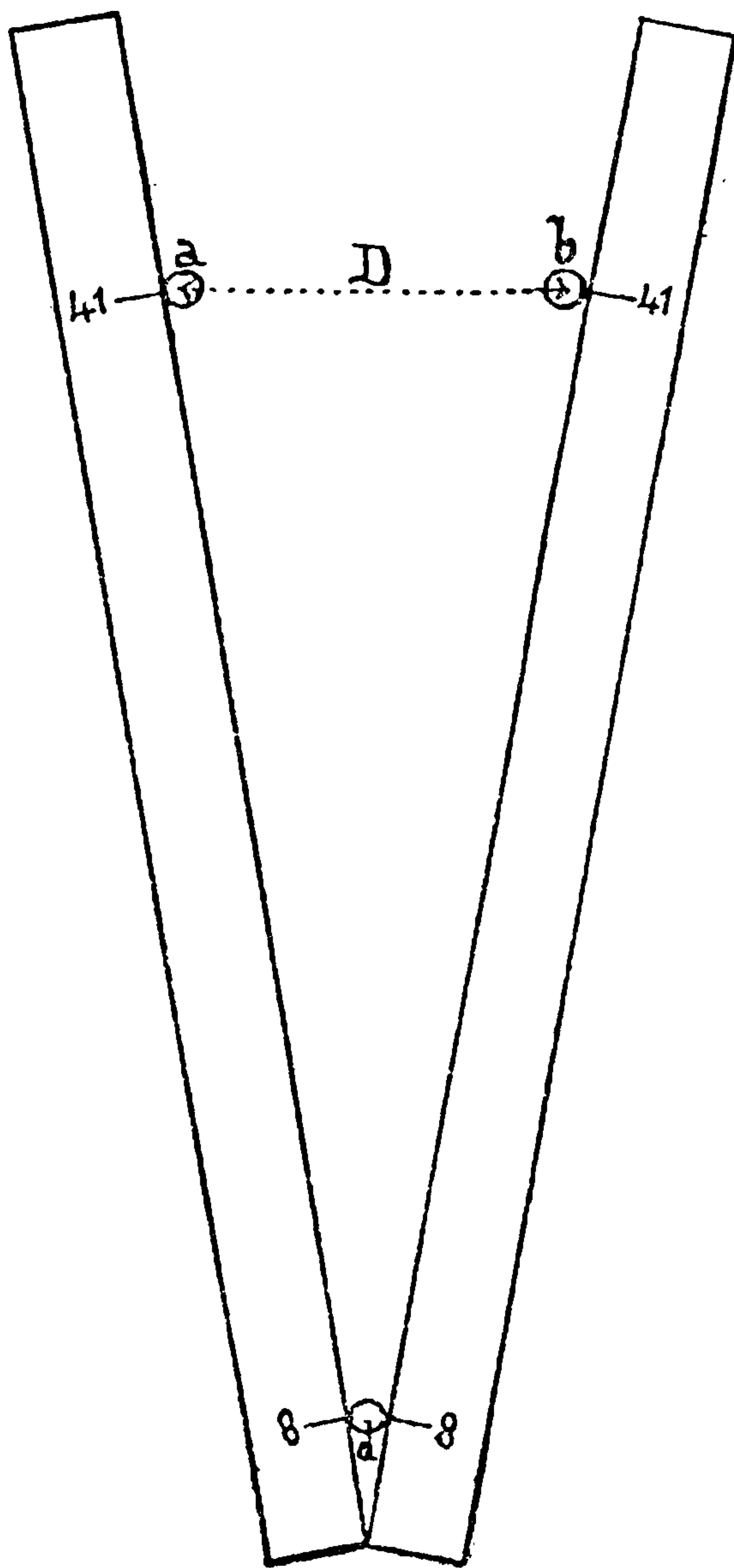

Fig. 76

### 286. The Proportional Compass and Stem-winding Gearings.

First—Gearing of the crown wheel in the ratchet wheel: The teeth of this gearing should be solid; this is the reason why only one-twentieth of play is given them (.223). For the same purpose the bottoms of the teeth are made with a rounded shape and the ogives of the teeth are shortened. These gearings are epicycloidal; the profiles are formed by epicycloids described by a point of a generating circumference smaller than half of the primitive circumferences. As we have just said, one does not use the whole of the epicycloidal arc for the tooth; it is sufficient that the contact be established three-fifths of the pitch before the line of centers, in order to be continued until three-fifths of the pitch beyond that line.



The "flank" of the tooth is no longer a straight line, but a *hypocycloid* described by a point of the same generating circle rolling on the interior of the primitive circumference of the wheel.

Thus (Fig. 77)  $ta$  is the useful epicycloidal arc, while  $ab$  is any curve whatever shortening the tooth; in this manner, the height of the ogive is not determined;  $td$  is a hypocycloidal arc generally approaching, very nearly, a straight line.

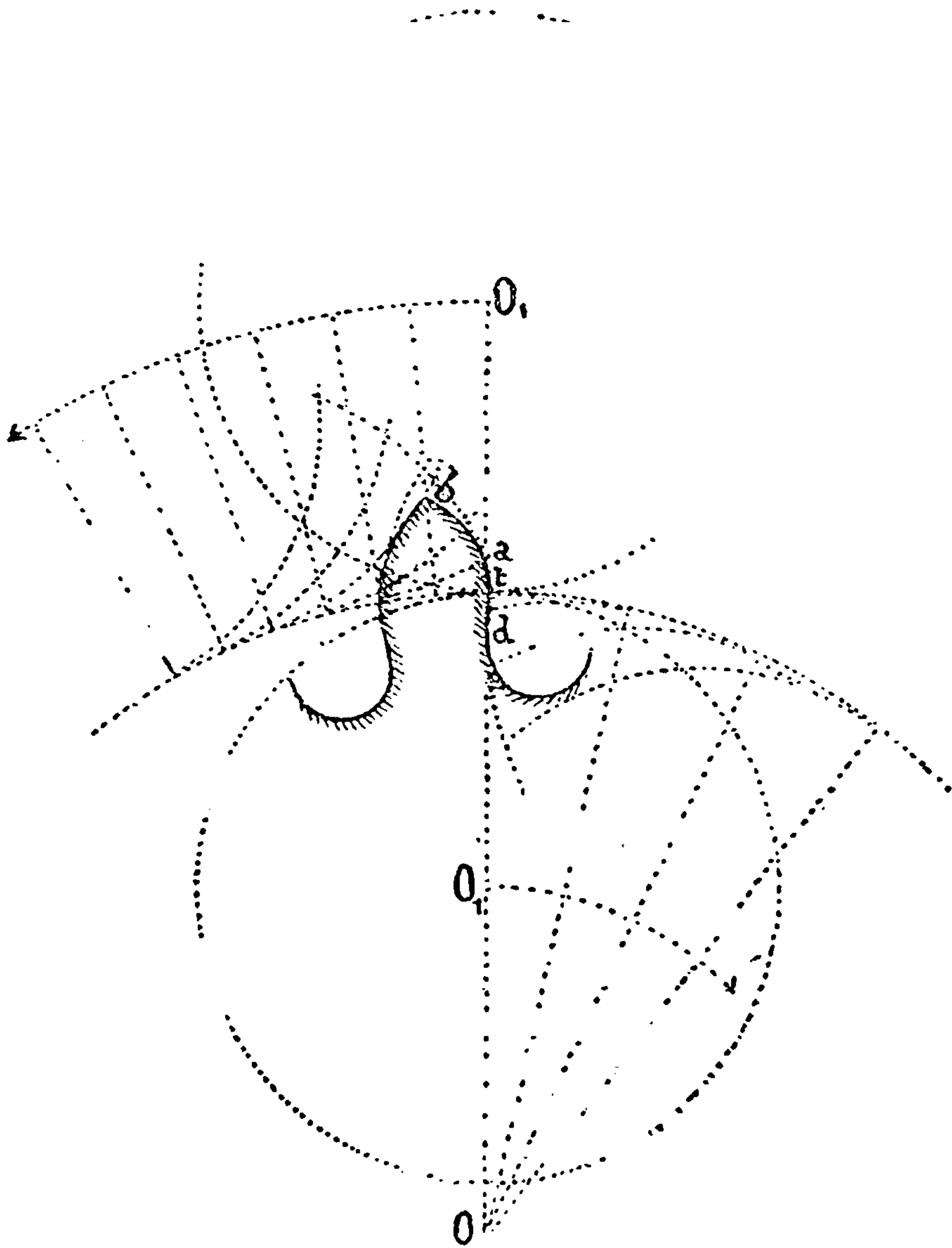

Fig. 77

To determine the height of the shortened ogive in units of diametrical pitch, it is necessary to proceed graphically or by simply estimating it by the eye

Generally, for this gearing, the height of the two ogives placed opposite to each other can be taken as  $2\frac{1}{4}$  diametrical pitch.

If, then,  $n$  and  $n'$  are the numbers of teeth, the crown wheel should be fitted to the division

$$n' + 2\frac{1}{4}$$

and in the same manner the ratchet to the division

$$n + 2\frac{1}{4}.$$





**THIS PAGE IS LOCKED TO FREE MEMBERS**

Purchase full membership to immediately unlock this page



# HISTORY

Tens of thousands of important historical sources, many previously unobtainable, are now available for the first time with a Forgotten Books Full Membership.

Unlimited Access  
\$8.99/month

**Continue**

\*Fair usage policy applies



**288. Gearing of the Sliding Pinion and of the Small Setting Wheel.** Although one could not make use of the proportional compass for the study of the relative dimensions to be given to the mobiles of this gearing, and as this determination should be entirely a matter of calculation, we give here, however, the theory, which will not be found out of place.

Suppose (Fig. 80)  $r$  to be the primitive radius of the small setting wheel,  $R$  its total radius and  $n$  the number of its teeth;

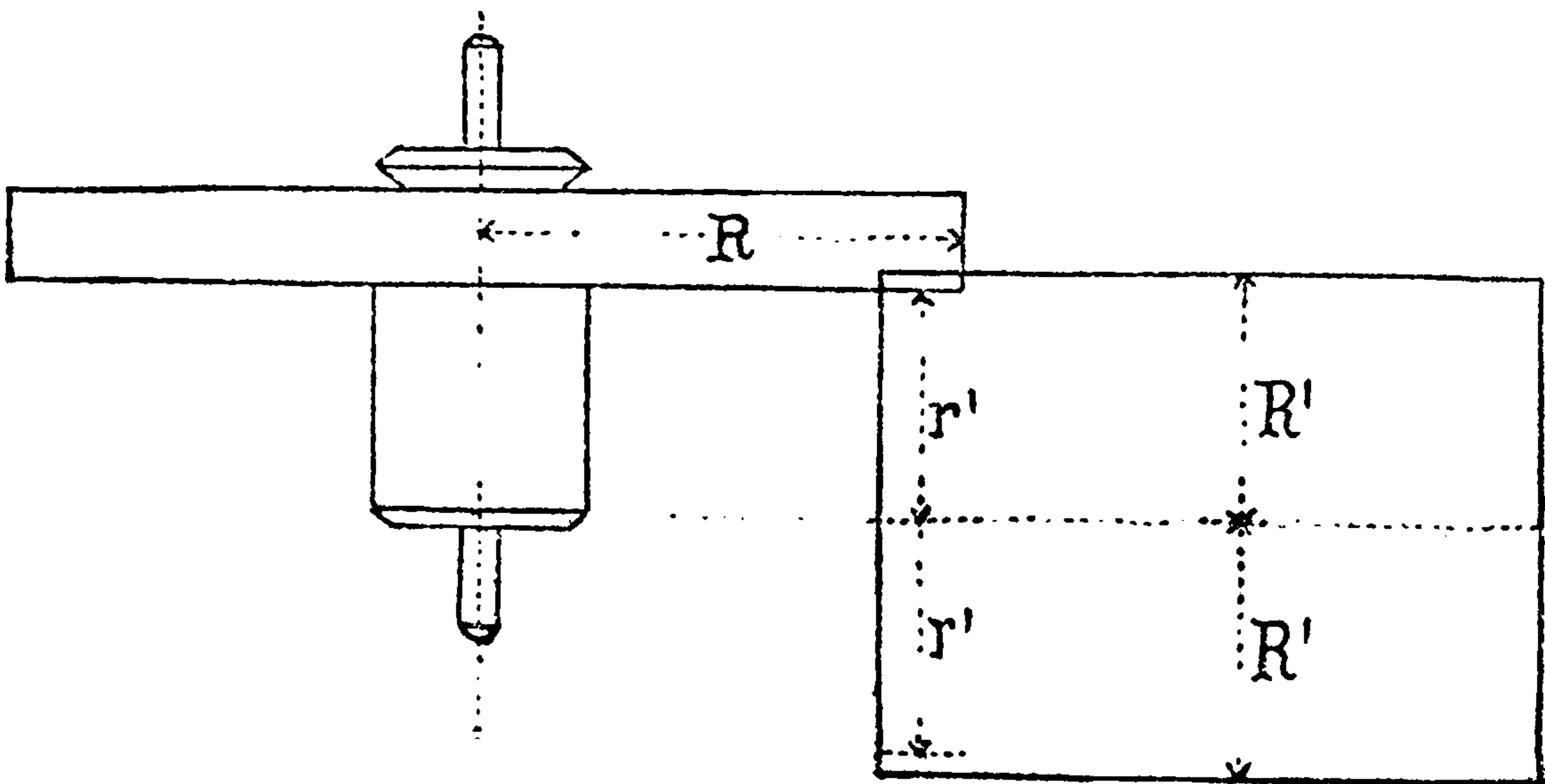

Fig. 80

$r'$  the radius of the sliding pinion abutting on the under side of the small winding wheel,  $R'$  its total radius and  $n'$  the number of its teeth.

In the generality of cases, one can admit that

consequently,

$$R' - r' = 0.2 \text{ mm.};$$

$$r' = R' - 0.2.$$

If the penetration of the two mobiles is greater, the gearing does not work well. Generally, it is desired in practice to determine the number of teeth  $n'$  in the sliding pinion.

The proportion

$$\frac{r}{r'} = \frac{n}{n'}$$

gives us the value

$$(I) \quad n' = n \frac{r'}{r}.$$

By an analogous reasoning to that of (286) one can place

$$\frac{r}{R} = \frac{n}{n + 2},$$

from whence one draws

$$r = \frac{R n}{n + 2}$$







**Various Calculations Relative to Gearings.**

**290.** The preceding table (283) gives a second factor for the various gearings which it includes, expressing the radius or total diameter of the mobile in function of the radius or primitive diameter equal to the unit. The use of these factors is important in cases where it is desired to determine the total dimensions of the wheels of a gearing by means of a rapid calculation ; for example, in the construction of calibres. The solving of the following problems will rapidly render us familiar with the use of this table :

**291.** *Being given the primitive radius of a wheel to calculate its total radius  $R$ .* To solve this question, the number of wheel teeth and of pinion leaves in which they should gear must be known. One seeks, therefore, in the second column of the table for the figures of the teeth range of the gearing, and the corresponding value indicated in the fifth column will give the factor by which the primitive radius of the wheel must be multiplied to obtain its total radius. One will, therefore, have

$$R = r \times \text{factor of the table.}$$

If, for example, the primitive radius  $r$  of a barrel with 80 teeth is 10 mm. and if this wheel ought to gear in a 10-leaf center pinion, the factor indicated by the table is 1.0423 ; therefore,

$$R = 10 \times 1.0423 = 10.423 \text{ mm.}$$

If we had to calculate the total radius of a barrel with 96 teeth, whose primitive radius should likewise be 10 mm. and gearing in a 12-leaf pinion, we would have

$$R = 10 \times 1.03904 = 10.3904 \text{ mm.}$$

One sees that the total radius of the latter barrel is a little less than that of the first.

**292.** *Being given the total radius of a wheel, to determine its primitive radius.* This question is the inverse of the preceding one and consequently is solved by dividing the total radius given by the tabulated factor. Therefore,

$$r = \frac{R}{\text{tabulated factor}}$$

Numerically, one has, if  $R = 10.423$ ,  $n = 80$  and  $n' = 10$ ,

$$r = \frac{10.423}{1.0423} = 10.$$





**THIS PAGE IS LOCKED TO FREE MEMBERS**

Purchase full membership to immediately unlock this page

# DELVE INTO FANTASY, MAGIC, MYTHOLOGY & FOLKLORE

Forgotten Books'  
Full Membership gives  
access to 797,885 ancient  
and modern, fiction and  
non-fiction books.

**Continue**

\*Fair usage policy applies



**295.** *Being given the primitive radius of a pinion, one desires the total radius of the wheel.* We have

$$r = r' \frac{n}{n'}$$

and

$$R = r \times \text{tab. fac.} = r' \frac{n}{n'} \times \text{tab. fac.}$$

Let  $r' = 0.86$ ,  $n = 80$ ,  $n' = 10$ . One will write

$$R = 0.86 \times \frac{80}{10} \times 1.0423 = 7.17.$$

**296.** *Being given the total radius of the wheel, to find the total radius of the pinion.* We have

$$r = \frac{R}{\text{tab. fac. of the wheel}}$$

and

$$r' = r \frac{n'}{n};$$

on replacing, it becomes

$$r' = \frac{n'}{n} \frac{R}{\text{tab. fac. of the wheel}}.$$

Afterward

$$R' = r' \text{ tab. fac. of the pinion};$$

consequently,

$$R' = R \frac{n'}{n} \frac{\text{tab. fac. of the pinion}}{\text{tab. fac. of the wheel}}.$$

Let, for example,

$$R = 10.2, n = 80, n' = 10,$$

$$\text{Tabulated factors} \begin{cases} \text{Wheel} = 1.0423 \\ \text{Pinion} = 1.15 \end{cases}$$

one will have

$$R' = 10.2 \times \frac{10}{80} \times \frac{1.15}{1.0423} = 1.4067.$$

**297.** *Being given the total radius of the pinion, to find the total radius of the wheel.* In an analogous manner to the preceding case, one will have

$$r' = \frac{R'}{\text{tab. fac. of the pinion}}$$

and

$$r = r' \frac{n}{n'}$$

from whence

$$r = \frac{R'}{\text{tab. fac. of the pinion}} \frac{n}{n'}.$$

And since

$$R = r \text{ tab. fac. of the wheel},$$

one has at last

$$R = R' \frac{n}{n'} \frac{\text{tab. fac. of the wheel}}{\text{tab. fac. of the pinion}}.$$



Let  $R' = 1.4067$ ,  $n = 80$ ,  $n' = 10$ , one will have

$$R = \frac{1.4067 \times 80 \times 1.0423}{10 \times 1.15} = 10.2.$$

**298.** *Being given the distance of the centers and the numbers of teeth in a gearing, to determine the total diameters of the wheel and pinion.* We know the formulas (185)

$$r = D \frac{n}{n + n'}, \text{ and } r' = D \frac{n'}{n + n'},$$

and since

$$R = r \text{ tab. fac. of the wheel,}$$

$$R' = r' \text{ tab. fac. of the pinion,}$$

one has

$$R = D \frac{n}{n + n'} \text{ tab. fac. of the wheel,}$$

$$R' = D \frac{n'}{n + n'} \text{ tab. fac. of the pinion.}$$

Let

$$D = 5.2, n = 70, n' = 7,$$

$$\text{Tabulated factors } \begin{cases} 1.0423 \text{ for the wheel} \\ 1.1995 \text{ for the pinion} \end{cases}$$

one will have

$${}^2 R = \frac{5.2 \times 70 \times 1.0423 \times 2}{77} = 9.854,$$

$${}^2 R' = \frac{5.2 \times 7 \times 1.1995 \times 2}{77} = 1.134.$$

**299.** *Being given the total radius of the wheel and the numbers of teeth of the gearing, one desires to find the distance between the centers of the two mobiles.* The formula

$$r = D \frac{n}{n + n'}$$

gives

$$D = r \frac{n + n'}{n},$$

and since

$$r = \frac{R}{\text{tab. fac. wheel}}$$

one will have

$$D = \frac{R}{\text{tab. fac. wheel}} \cdot \frac{n + n'}{n}.$$

Suppose

$$R = 4.927, n = 70, n' = 7,$$

$$\text{Tabulated factors of the wheel, } = 1.0423.$$

One places

$$D = \frac{4.927 \times 77}{1.0423 \times 70} = 5.2.$$

**300.** *Being given the total radius  $R'$  of a pinion and the numbers  $n$  and  $n'$  of the teeth of the gearing, to determine the distance of the centers  $D$ .*



In an analogous manner to the preceding case, we would write the formula

$$D = \frac{R'}{\text{tab. fac. pinion}} \cdot \frac{n + n'}{n'}$$

Suppose

$$R' = 0.567, n = 70, n' = 7,$$

one will have

$$D = \frac{0.567 \times 77}{1.1995 \times 7} = 5.2.$$

**301.** *Being given the diameter  $P$  of a watch plate, the numbers of teeth  $n$  of the barrel and  $n'$  of the center pinion, one desires to find: 1st, the primitive radii  $r$  and  $r'$  of the wheel and of the pinion; 2d, the distance of the centers  $D$  of the two mobiles; 3d, the total radii  $R$  and  $R'$ . The diameter of the barrel should be as large as possible. This question is generally one of the first which presents itself in connection with the establishing of a new watch calibre.*

In order to be able to fit the plate of a watch in its case, a "recess" is generally made on the exterior of this plate, which can be valued at one-sixtieth part of the total diameter  $P$ . There remains, therefore, only  $\frac{59}{60}$  available. The useful radius is, consequently,

$$\frac{1}{2} \frac{59}{60} P = \frac{59}{120} P.$$

The extremity of the teeth range in the barrel can coincide with the extremity of this radius, the teeth finding the necessary play in the hollowed-out part in the center of the case.

The radius  $\frac{59}{120} P$  should be equal to the sum of the following lengths: the primitive radius  $r'$  of the center pinion, the primitive radius of the barrel and its total radius (Fig. 81).

One would, therefore, have

$$\frac{59}{120} P = r' + r + R.$$

But since

$$r' = r \frac{n'}{n}$$

and

$$R = r \text{ tab. fac.},$$

one will also have  $\frac{59}{120} P = r \frac{n'}{n} + r + r \text{ tab. fac.},$

or, again,

$$\frac{59}{120} P = r \left( \frac{n'}{n} + 1 + \text{tab. fac.} \right)$$





**THIS PAGE IS LOCKED TO FREE MEMBERS**

Purchase full membership to immediately unlock this page



# HISTORY

Tens of thousands of important historical sources, many previously unobtainable, are now available for the first time with a Forgotten Books Full Membership.

Unlimited Access  
\$8.99/month

**Continue**

\*Fair usage policy applies



or also

$$r = \frac{59 \times 43}{120 \left(\frac{1}{8} + 1 + 1.0423\right)} = \frac{59 \times 43}{260.086}$$

and

$$r = 9.7545.$$

It follows that

$$r' = \frac{9.7545}{8} = 1.2193.$$

Then

$$D = 9.7545 + 1.2193 = 10.9738,$$

and finally

$$\begin{aligned} R &= 9.7545 \times 1.0423 = 10.17. \\ R' &= 1.2193 \times 1.15 = 1.4. \end{aligned}$$

Since one has

$$\frac{59}{120} \cdot 43 = 21.1416,$$

one should have likewise, or very nearly,

$$r' + r + R = 21.1416.$$

The addition gives

$$\begin{array}{r} 1.2193 \\ 9.7545 \\ 10.17 \\ \hline 21.1438. \end{array}$$

With this approximation the result is satisfactory.

**302.** *Being given the total radius  $R'$  of the pinion in which the rack of a repeater gears, the number  $n'$  of teeth according to which the pinion is divided\* and the total radius  $R$  of the rack, one desires to find the number according to which the sector of this last wheel must be cut.*

Let us admit the ogive of the teeth range of the two mobiles equal to twice the diametrical pitch (277). We will have the primitive radius of the pinion by the formula

$$r' = \frac{R' n'}{n' + 2}$$

and that of the wheel

$$r = \frac{R n}{n + 2}$$

Since one has

$$\frac{r'}{r} = \frac{n'}{n},$$

one can also write

$$\frac{n'}{n} = \frac{\frac{R' n'}{n' + 2}}{\frac{R n}{n + 2}} = \frac{R' n' (n + 2)}{R n (n' + 2)},$$

\*One knows that the division of this pinion by the set of teeth is not complete, for the reason that this mobile only executes a fraction of a turn. The pitch of the gearing left full facilitates the arrest of the movement.



from whence  $n'. R n (n' + 2) = n. R' n' (n + 2)$

and, on simplifying,

$$R (n' + 2) = R' (n + 2).$$

One finally obtains

$$n = \frac{R}{R'} (n' + 2) - 2.$$

Suppose, for example,  $R = 9.96$ ,  $R' = 1.8$ ,  $n' = 13$ , we would have :

$$n = \frac{9.96 \times 15}{1.8} - 2 = 81 \text{ teeth.}$$

REMARK.—One could obtain directly the above formula by a proportion analogous to that of 289,

$$\frac{R}{R'} = \frac{n + 2}{n' + 2}.$$

**303.** The following problem does not find its solution in the theory of gearings only, but also in that of trains and of the motive force. It recalls to our mind, in an excellent manner, the studies that we have gone over, so we do not hesitate to close this series of problems by joining together some of the various questions which we have treated in this chapter and in those which have preceded it.

**304. Problem.** A horologist has constructed a stem-winding watch the diameter of whose plate is 50 millimeters (22 lines). Upon winding the watch, he notices that the power necessary to operate the winding works, that is to say, to overcome the force opposed by the spring to the movement, is too great. He decides then to manufacture a new watch, like the first, but in which the winding can be more easily effected. He should, therefore, modify the value of the two factors which enter into the expression of the mechanical work : the *force* on the one hand and the *time* employed for the winding on the other ; in other words, the *space* traversed by the point of application of the active force (37).

The first watch has its barrel furnished with a stop work of 4 turns, and runs for 32 hours ; the second should run for the same number of hours. It is evident that if we introduce into the second watch a barrel furnished with a stop work, allowing it to make 5 rotations during 32 hours, we will have diminished the average tension of the force and augmented at the same time the duration of the winding.



Let us seek, therefore, for the nature and the value of the change that must be made in the second construction, in order to arrive at the end desired.

**305.** In the first place, the relation between the numbers of teeth in the barrel and of leaves in the center pinion must be changed.

In the first watch, this relation was  $\frac{96}{12}$ , which gave a length of running

$$\frac{96}{12} \times 4 = 32 \text{ hours.}$$

In the second watch, one should also have

$$\frac{n}{n'} \times 5 = 32 \text{ hours,}$$

or

$$\frac{n}{n'} = \frac{32}{5} = 6.4.$$

On choosing a pinion of 10 leaves, one will have

$$n = 6.4 \times 10 = 64 \text{ teeth,}$$

or a pinion of 15 leaves,

$$n = 6.4 \times 15 = 96 \text{ teeth.}$$

It is not an absolute necessity, in general, to conserve the above relation in a very strict manner. Thus, if one wished a pinion with 12 leaves, one would have

$$n = 6.4 \times 12 = 76.8 \text{ teeth.}$$

This fractional number not being practical, let us admit, for example,

$$n = 78.$$

We would then have

$$\frac{78}{12} \times 5 = 32.5 \text{ hours.}$$

The watch would run, with the above number, half an hour longer than was desired.

Since, for a watch of 50 mm. diameter, a barrel with 96 teeth does not give too weak a teeth range, one can accept for this gearing

96 teeth for the barrel,  
15 leaves for the center pinion.

**306.** The primitive radii of the two mobiles must now be calculated and the distance between their centers. Let us commence by seeking for these values in the first watch, in order to compare the results.





**THIS PAGE IS LOCKED TO FREE MEMBERS**

Purchase full membership to immediately unlock this page

# DELVE INTO FANTASY, MAGIC, MYTHOLOGY & FOLKLORE

Forgotten Books'  
Full Membership gives  
access to 797,885 ancient  
and modern, fiction and  
non-fiction books.

**Continue**

\*Fair usage policy applies



0.36 less than the primitive radius. That of the second watch could, therefore, be

$$11.17 - 0.36 = 10.81 \text{ mm.}$$

The interior radius of the drum was, in the first case,

$$11 - 0.77 = 10.23;$$

consequently, it could be, in the second case,

$$10.81 - 0.77 = 10.04 \text{ or } 10 \text{ mm.}$$

**308.** Let us now calculate the dimensions of the hub, and the dimensions as well as the *force* of the spring.

In the first watch, when the spring is pressed against the side of the drum, it occupies the third of the interior radius of the barrel, another third remains empty and the third third is occupied by the hub. This spring makes, in this position, 15 turns and 4.5, placed loosely on a table; the number of turns of development is 6.5.

The dimensions of the blade are the following :

$$\begin{aligned} \text{Thickness} &= 0.21 \\ \text{Height} &= 3.9 \\ \text{Length} &= 780 \text{ mm.} \end{aligned}$$

According to the formula (97)

$$F = \frac{E h e^3 2 \pi n}{12 L}$$

the moment of the force of this spring is for  $n = 1$ ,

$$F = 557.64.$$

When the spring is coiled up, that is to say, when the watch is completely wound, one has

$$n = 15 + 6 - 4.5 = 16.5;$$

consequently,

$$F = 16.5 \times 557 = 9190 \text{ gr.}$$

When the spring is down, one has  $n' = 12.5$  and

$$F' = 12.5 \times 557 = 6942 \text{ gr.}$$

In order that the center wheel may receive in the second watch the same force at the beginning and at the end of the tension of the spring, it is necessary that, the watch being wound, one should have

$$F_1' = \frac{4}{5} \times 9190 = 7352 \text{ gr.,}$$

and if the watch is run down

$$F_1' = \frac{4}{5} \times 6942 = 5553 \text{ gr.,}$$



since for the same number of teeth in the barrels the relation of the leaves and pinions is

$$\frac{12}{15} = \frac{4}{5}.$$

In order that this difference between the moments of extreme force may exist with 5 turns of the stop work, one must have the proportion

$$\frac{16.5}{12.5} = \frac{n_1' + 5}{n_1'};$$

from whence one finds

$$n_1' = 15.625,$$

and afterwards

$$n_1 = 20.625 \frac{5}{4} n.$$

**309.** Let us further calculate the thickness of the spring. Let  $e$  be this thickness for the spring in the first watch and  $e'$  that of the spring in the second.

For the first case we have the moment

$$F = \frac{E h e^3 2 \pi n}{12 L}$$

and for the second

$$\frac{4}{5} F = \frac{E h e'^3 2 \pi \frac{5}{4} n}{12 L \cdot \frac{e}{e^1}},$$

on remarking that the length  $L$  increases in inverse relation to the diminution of the thickness  $e$ .

One could, therefore, place

$$\frac{4}{5} \cdot \frac{E h e^3 2 \pi n}{12 L} = \frac{E h e'^3 2 \pi \frac{5}{4} n}{12 L \cdot \frac{e}{e^1}},$$

from whence, on simplifying, one obtains

$$\frac{4}{5} e^3 = \frac{\frac{5}{4} e'^3}{\frac{e}{e^1}}$$

and

$$\frac{4}{5} e^4 = \frac{5}{4} e'^4;$$

therefore,

$$25 e'^4 = 16 e^4,$$

from whence

$$e' = e \sqrt[4]{\frac{16}{25}} = e \sqrt{\frac{4}{5}}.$$

For  $e = 0.21$ , one has

$$e' = 0.21 \times 0.894427 = 0.188830.$$

**310.** Since we have the proportion

$$\frac{L}{L'} = \frac{e'}{e},$$



one could finally calculate the new length of the spring on placing

$$L' = L \frac{e}{e'};$$

therefore;

$$L' = \frac{1}{0.894427} \cdot 780,$$

and

$$L' = 872 \text{ mm.}$$

Since the second barrel is a little smaller than the first, this spring will fill it a little more than one-third; but as it is also thinner, one can diminish the hub proportionately to the relative thickness of the spring (111).

Thus, the first hub having a radius equal to one-third of the interior radius of the barrel, this one would be  $\frac{1}{3} = 3.66 \dots$  mm.

This radius being 17.777 times greater than the thickness of the spring, the second hub could be

$$17.777 \times .18826 = 3.34 \dots \text{ mm.}$$

**311.** We know, moreover, the means of increasing the ease of the winding by increasing the number of teeth in the ratchet and of the contrate teeth range in the crown wheel; since we have already treated this question (169), we will not go back to it here and we will thus admit that the problem proposed is solved.

### Conical Gearings.

**312.** In the gearings that we have just considered, the two axes are parallel to each other and we know that the movement of the system can be compared to that of two *cylinders* mutually conducting each other by simple contact. We have designated gearings of this sort under the name of *cylindrical gearings*.

**313.** If, in place of being parallel, the two axes are concurrent, one can imagine that the movement of one produces the movement of the other by the contact of two cones concentric to each of the two axes (Fig. 82). This system takes, therefore, the name of *conical gearing*.

The two axes can form any angle whatever with each other; we will treat particularly the special case where this angle is a right angle, almost the only case in horology.

Suppose (Fig. 82)  $Ox$  and  $Oy$ , two perpendicular axes around which turn the two cones  $COB$  and  $AOC$ ; let us admit that their movement is produced without slipping.





**THIS PAGE IS LOCKED TO FREE MEMBERS**

Purchase full membership to immediately unlock this page

# HISTORY

Tens of thousands of important historical sources, many previously unobtainable, are now available for the first time with a Forgotten Books Full Membership.

Unlimited Access  
\$8.99/month

**Continue**

\*Fair usage policy applies





**315. Form of the Teeth.** As in the cylindrical gearings, the transmission of the movement cannot be effected practically by the simple contact of the two *primitive cones*; one is generally obliged to supply these cones with flanges, that is to say, with teeth, which make them move as if they were driven by their simple adhesion.

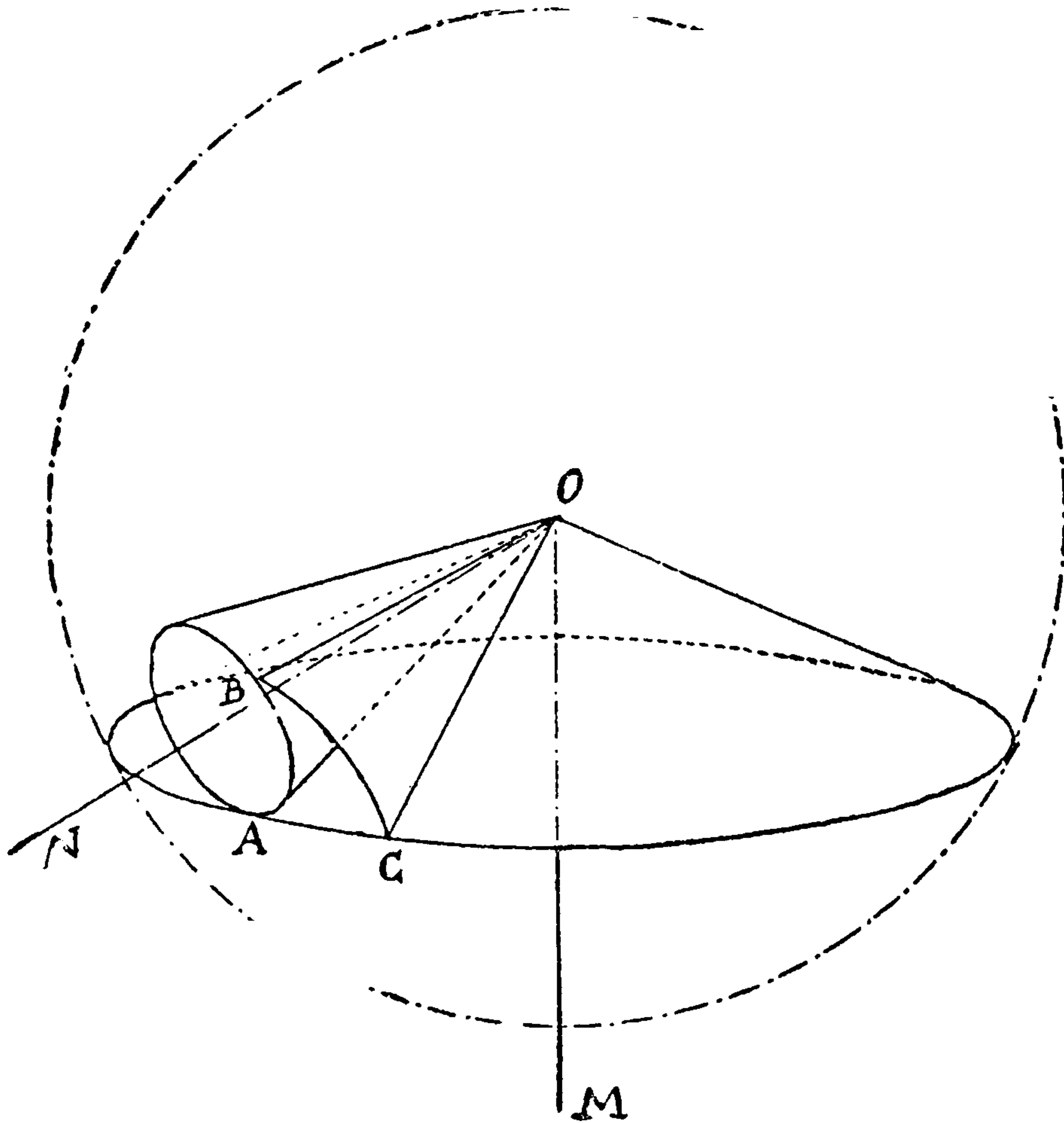

Fig. 83

The contact, consequently, is not always found on the line  $O C$ ; if we consider the contact at the point  $C$ , the displacement of this contact should take place on the surface of a sphere whose center is at  $O$  and passing through the points  $A C B$ . The form of the teeth must be traced on this sphere.

Thus,  $M O$  and  $O N$  (Fig. 83) being the two axes of rotation which meet in a point  $O$ , let us take this point as center of a sphere; it will contain the two upright cones, as we have just said, having their common summit at the center  $O$ , and will cut them along two circumferences, of their bases, tangent at the point  $A$  belonging to the generatrix of contact of the two cones.

These circumferences drive each other, exactly as would the primitive circumferences of a cylindrical gearing situated in the same plane. The sphere playing the role of the plane considered



in the first case, all the properties already determined are here reproduced.

Thus, one can determine the curve described by a point of one of these primitive circumferences by making one of the cones roll on the other which remains immovable; the curve thus engendered is the *spherical epicycloid*  $B C$ .

On account of the similarity of the methods employed in this case with those that we have previously described, we will not enter into all the details of these constructions.

**316.** Let us examine, however, the case of *flank gearings*. The flank being a diametrical plane of the primitive cone, the driving tooth will be a conical surface whose form must be determined.

Suppose  $S O$  and  $S O'$  the axes of the two primitive cones which should turn while touching along an edge  $S M$  (not represented in the Fig. 84). Suppose  $M m N$  and  $M m' N'$  the circum-

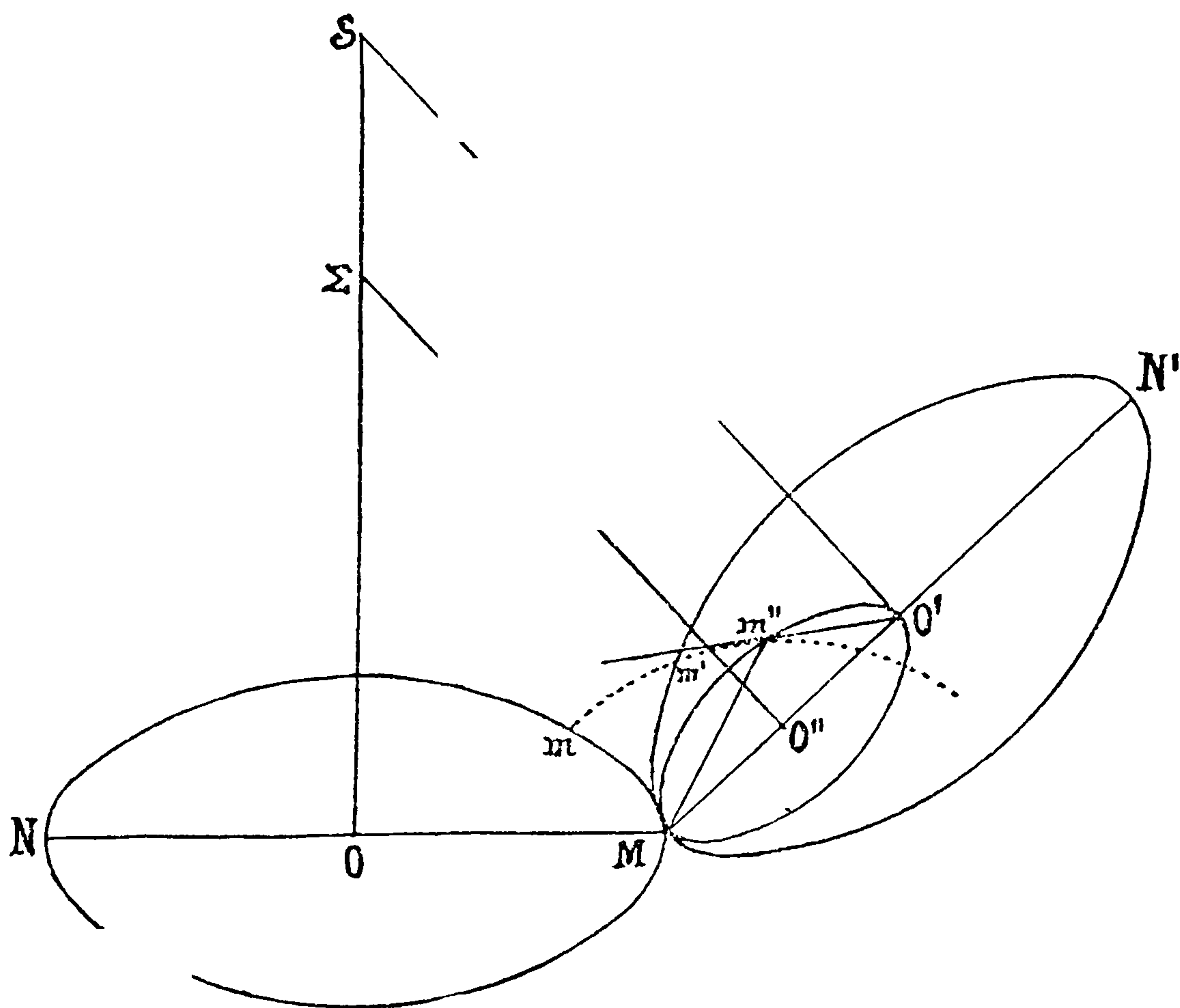

Fig.

ferences of the circles proceeding from the intersection of the two cones by the planes drawn perpendicularly through the point  $M$  to their respective axes. On the radius  $M O'$  of the circle  $O'$  as diameter, one describes a circumference  $O''$  and through its center



$O''$  one erects a perpendicular on its plane ; this perpendicular will meet the axis at a point  $\Sigma$ .

If one considers this point  $\Sigma$  as the common summit of two cones having for bases the two circles  $O$  and  $O''$ , and if one makes the second cone  $\Sigma O''$  roll on the first  $\Sigma O$ , a point of the circumference  $O''$  will describe a curve  $m m''$ , a *spherical epicycloid*, situated on the sphere on which is moved the circle  $O''$  itself, sphere having its center at  $\Sigma$ .

If one made a cone which had its summit at the point  $S$  pass through this epicycloid, this cone will be the exterior surface of a diametrical plane of the cone  $S O'$  and should consequently be taken for the surface of the cone  $S O$ . This result appears evident from the similarity in the construction of cylindrical gearings, therefore, we will add no other proof to the application of this development by analogy.

317. Besides the epicycloidal form, one employs also the evolute of circle for the teeth of conical gearings.

318. **Construction of Conical Gearings.** By the preceding, all the lines which enter into conical gearings being defined, it is only necessary to apply the principles of descriptive geometry to deduce from them the outlines necessary for its construction. But it is useless to enter into extended details with

regards to this, since in practice a more simple method has been adopted and one sufficiently exact.

In order to represent these forms in a more convenient manner on paper, one substitutes for the spherical surface the plane surface projected at  $F C G$  (Fig. 85) perpendicular to the line of tangency of the primitive cones  $O C$ . On this surface

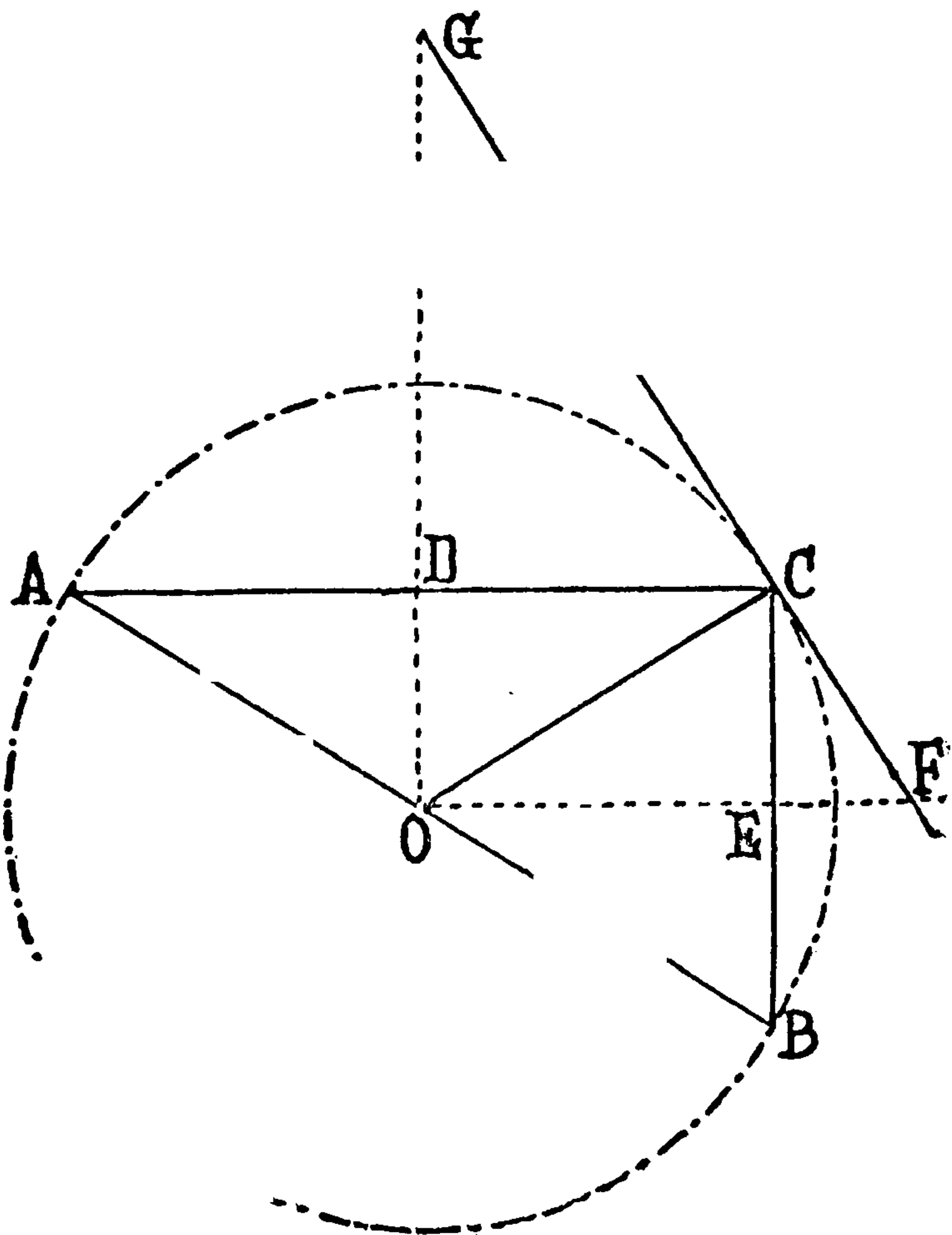

Fig. 85





**THIS PAGE IS LOCKED TO FREE MEMBERS**

Purchase full membership to immediately unlock this page

# DELVE INTO FANTASY, MAGIC, MYTHOLOGY & FOLKLORE

Forgotten Books'  
Full Membership gives  
access to 797,885 ancient  
and modern, fiction and  
non-fiction books.

**Continue**

\*Fair usage policy applies







In order to determine now the total radius  $O'' I''$ , corresponding to the point  $I'$ , let us project this point  $I'$  on the plane  $F G$  at  $I$ ; draw the radii  $O I$  prolonged to  $M$ ; the point of intersection  $M$  of this radius with the plane  $B C$  gives the total radius  $E M$  that one can project on  $O'' I''$ ; from the center  $O''$  describe afterwards the total circumference of the wheel.

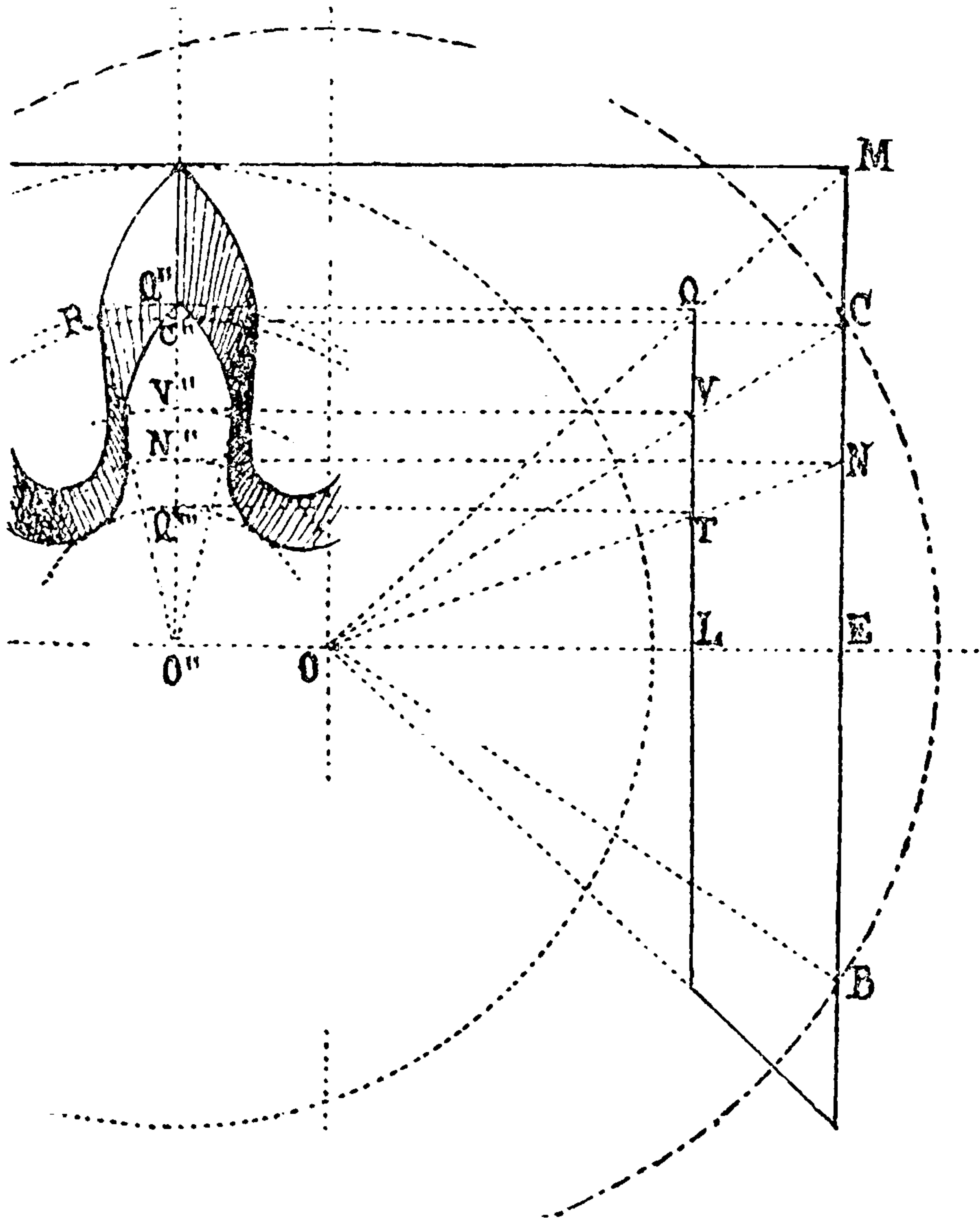

Fig. 88

One proceeds in an analogous manner to determine the bottom of the teeth on the plane  $B C$  by projecting the point  $K'$  on  $F G$ , drawing the radius  $O K$  cutting the plane  $B C$  at  $N$  and projecting this point at  $K''$ ; one will have thus the radius  $O K''$  of the circumference passing through the base of the teeth.

In order to determine finally any point  $P''$  of the form of the teeth, project the point  $P'$  to  $P$  on  $F G$ , draw the radius  $O P U$  and project the points  $P U$  on  $O'' I''$ . From the center  $O''$  one causes to pass through the points obtained arcs of a circle and lays off the half thickness  $S' P'$  on the circle passing through  $S''$ ; and



draws, afterwards, the radius  $O'' T''$ . The point  $P''$  at which this radius just cuts the circle projected from  $U$ , is the point of the tooth.

Let us still seek for the form of the teeth which appears on the interior plane  $L Q$  parallel to the plane  $B C M$  (Fig. 88).

On the side elevation, the point  $Q$  represents the point of the teeth. Project this point on the front elevation, at  $Q''$ , and describe from  $O''$  as center the circumference which passes through this point and which gives us the point of the teeth. To obtain the point  $T''$  of the base of the teeth, draw the radius  $O N$ , cutting the plane  $L Q$  at  $T$  and project this point on the front elevation, we will thus obtain the point  $T''$  through which one passes the circumference of the base of the teeth.

In order to further obtain any points whatever, for example, those which are found on the primitive cone, one draws the radius  $O C$ , cutting the plane  $L Q$  at  $V$ , projects this point on the front elevation, at  $V''$  and describes the circumference from the center  $O''$ . One afterwards draws the radius  $O'' R$ ; the points determined by the intersection of this radius with the circumference passing through  $V''$ , are points of the curve of the teeth. One can thus determine as many points as one desires and represent in this manner the complete form of the tooth.

Let us remark that, compared with the form determined for the teeth on the plane  $F G$  (Fig. 87), the form obtained on the front elevation having  $O''$  as center, is elongated. One should, therefore, take account, in practice, of the elongated shape of the teeth in these wheels compared with those of corresponding plane gearings.

The drawing of the front elevation of the wheel is made in exactly the same manner.

#### **Defects which Present Themselves in these Gearings.**

**320.** When, in a gearing, the normal to the point of contact does not pass through the point of tangency of the primitive circumferences, the transmission of the force is irregular.

The faults of construction which most often produce this effect, are :

First—A relative disproportion between the total diameters of the two wheels.

Second—A gearing too close or too slack.

Third—A bad teeth range.





**THIS PAGE IS LOCKED TO FREE MEMBERS**

Purchase full membership to immediately unlock this page



# HISTORY

Tens of thousands of important historical sources, many previously unobtainable, are now available for the first time with a Forgotten Books Full Membership.

Unlimited Access  
\$8.99/month

**Continue**

\*Fair usage policy applies



conducts, first, the excess, the normal cuts the line of centers between the point  $a$  and the center  $O'$  of the pinion.

Fig. 91 shows the case of a bad teeth range; the tooth, too short, for example, has its contact with the leaf, as in the preceding case: the normal passes between the point  $a$  and the center  $O'$  and one has a diminution of the force transmitted.

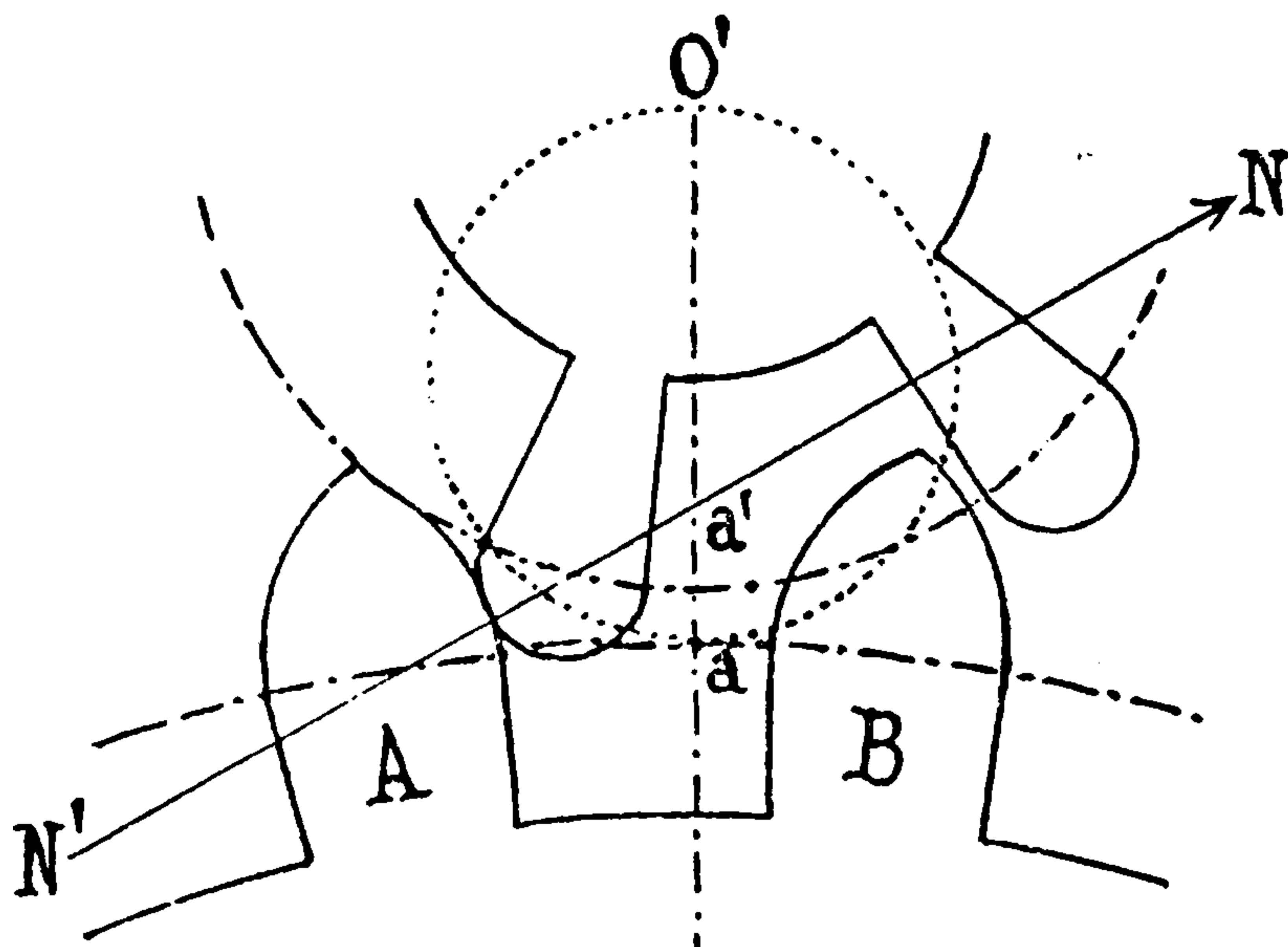

Fig. 90

When the above defects are not too much accentuated, it is possible to remedy them, in order to obtain a passable gearing; but, at least in the first case, it is impossible to arrive at absolute perfection.

If the pinion is slightly too large, one can touch up the wheel

in such a manner as to free the teeth range at the base  $a b$  (Fig. 92) and make it less pointed, after the manner of the English teeth range.

If the gearing is too slack, one increases the diameter of the wheel by careful forging.

If the teeth range is defective, one can try to rectify it by means of a suitable ordinary cutter, or, still better, with an Ingold cutter.

**322.** If the first contact of the tooth with the leaf commences after the line of centers, it may happen that at a certain moment of the movement the angular speed of the wheel becomes proportionately greater than that of the pinion which it conducts. This defect is the *drop*; it is produced by

- (1) Too close a gearing.
- (2) A pinion proportionally too small.
- (3) A bad teeth range.



Fig. 93 shows too small a pinion ; the pitch of the gearing of the wheel is greater than that of the pinion. When the tooth *B* should cease the contact on the generating circle, the tooth *A* is still found removed from the leaf that it should conduct. The tooth *B* will slip along the flank of the leaf and at this instant the normal to the point of contact will not pass through the point of contact of the primitive circumferences, but will cross the line of centers at a point nearer the center of the wheel. One will, therefore, have, in this case, an increase of the force transmitted. For a uniform movement of the pinion, the wheel will take an accelerated movement ; this is, technically speaking, a "drop."

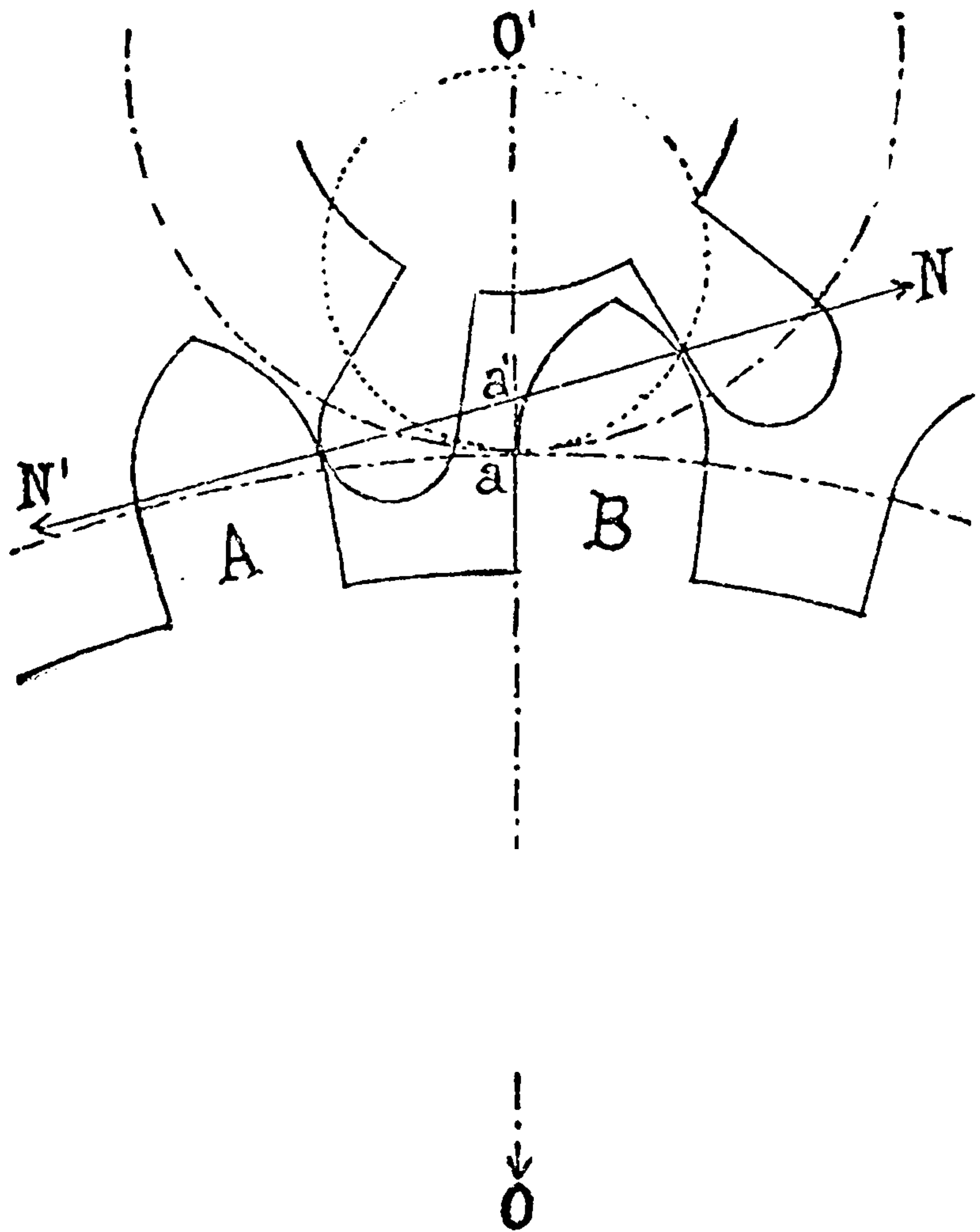

Fig. 91

Fig. 94 represents too deep a gearing, the tooth *B* conducts its leaf farther than the generating circumference ; there is, therefore, produced a slipping of the point of the tooth against the flank of the leaf, the accelerated movement which the wheel takes terminates by a drop of the tooth which follows on the leaf which it will conduct. The direction of the normal at the point of contact shows that one has, in this case, also an increase of the force transmitted.

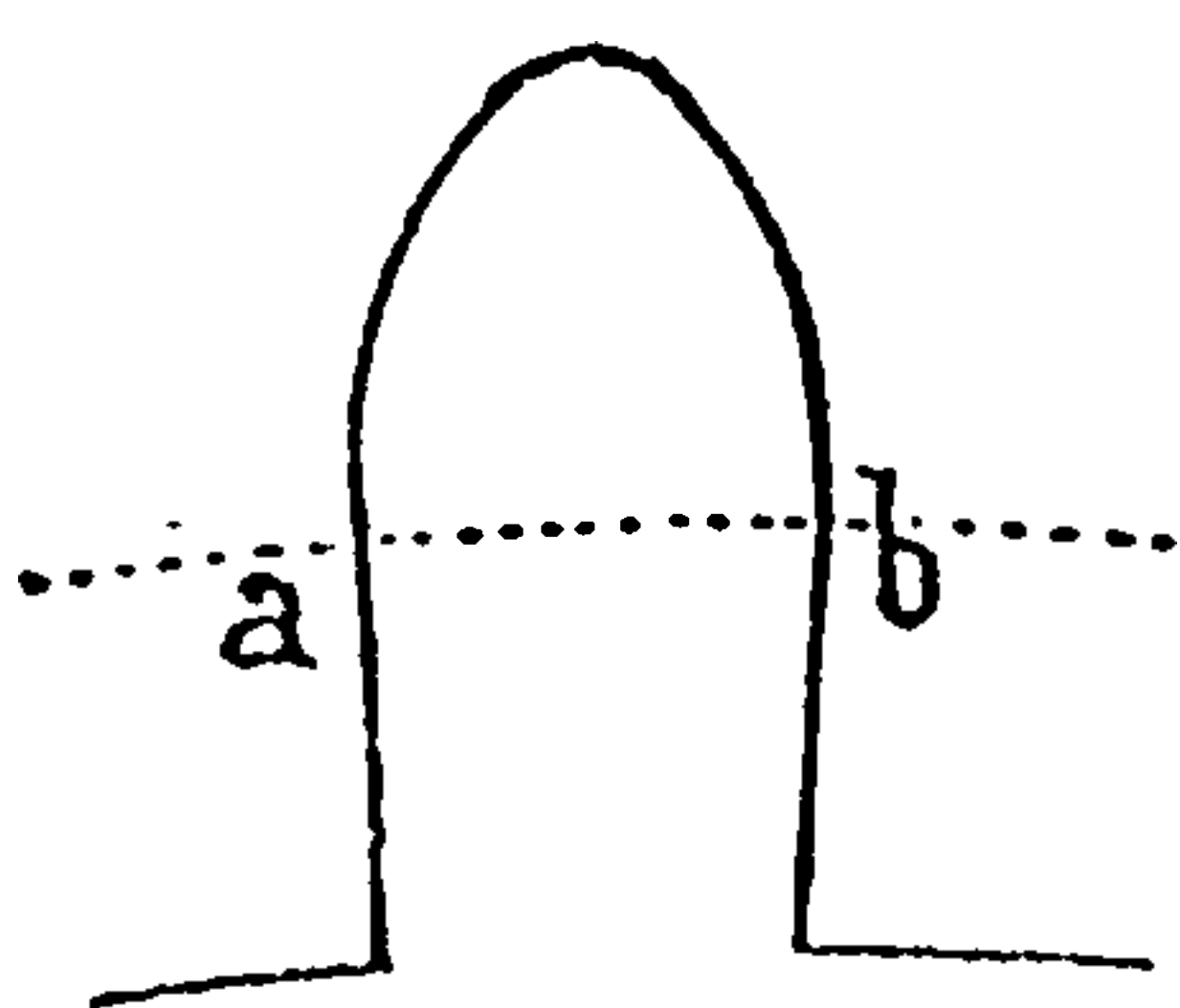

Fig. 92

Fig. 95 represents the case of a bad teeth range of the wheel. The teeth, which are too long, drive the pinion leaves farther than they should geometrically ; one can thus recognize the drop which will be produced.

A gearing presenting the above defects can be corrected by diminishing the height of the



ogive in such a manner that the teeth drive the leaves a less distance or, otherwise, by forming the teeth in such a manner as to give them a greater breadth on the primitive circumference.

**323.** On proving, as we have just done, that the gearing of a wheel in too large a pinion produces a butting, that, on

the other hand, too deep a gearing produces a drop, one sees that it is best to make a deep gearing when the pinion is too large.

Reciprocally, a gearing whose pinion is too small should be relatively shallow.

**324.** A defect which one encounters often enough in gearings is that which is occasioned by pinions whose leaves are not long enough, that is to say, pinions which are not cut deep enough. If the teeth of the wheel are correct, one finds very often the point of the tooth in contact with the bottom of the leaves (core of the pinion). If

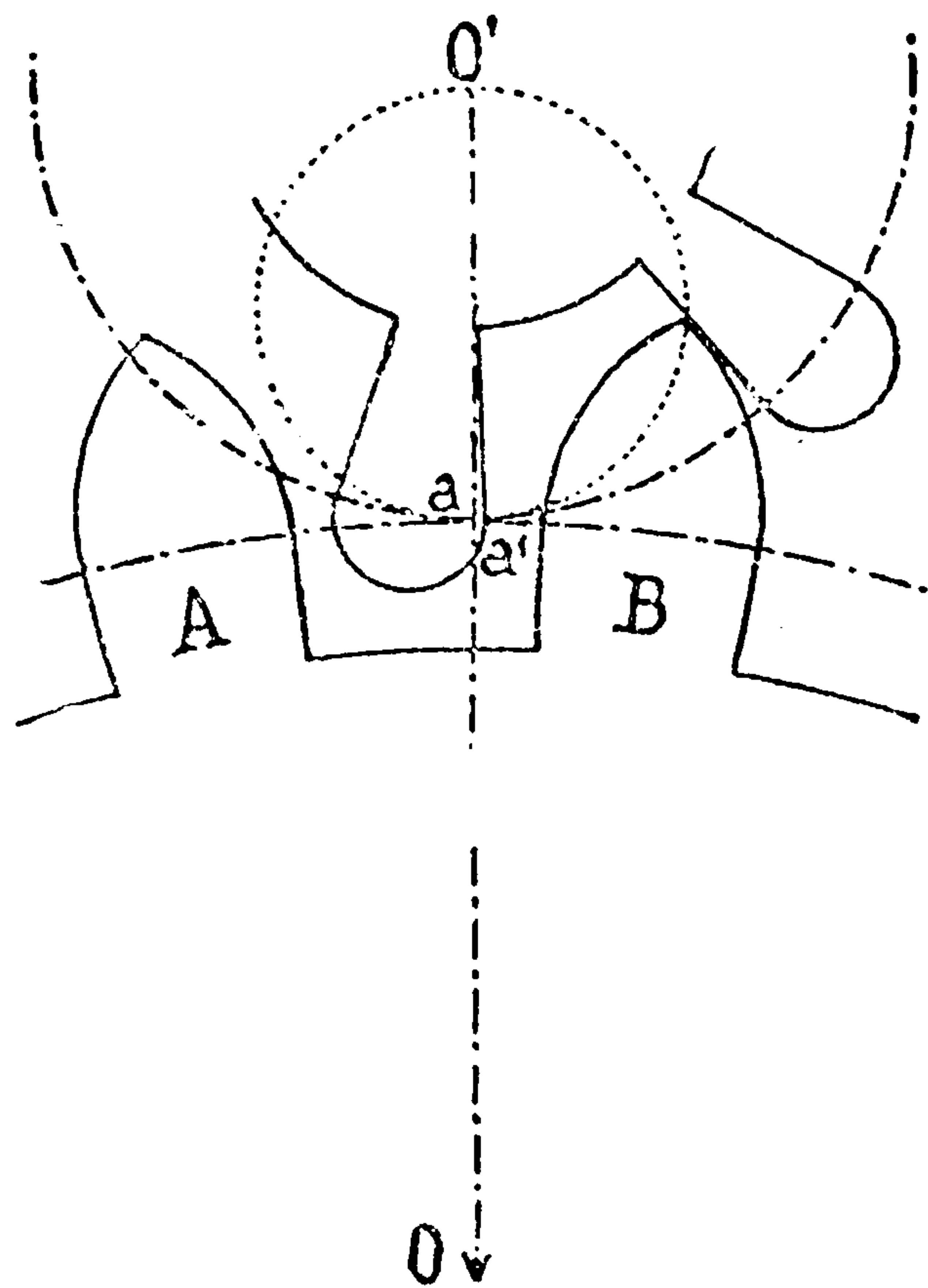

Fig. 93

one cannot change the pinion, which is the only means to obtain a perfect gearing, the ogives of the teeth must then be shortened, either by cutting off the points or by modifying the shape. One understands that in these cases absolute perfection exists no longer, especially if the number of pinion leaves is small; since then the contact should commence before the line of centers.

**325.** One encounters very often, also, pinions of ordinary quality in which the flanks of the leaves are not directed toward the center, but are diverted more or less from it. Such pinions should be rejected as much as possible if one wishes to preserve in the gearing the quality of a flank gearing; if not, the tooth of the wheel would have to be formed by means of a curve described as we have indicated (215).

In a gearing, defective either on account of the shape or direction of the pinion leaves or the wheel teeth, if one modifies one of the two profiles it might happen that one arrives at a correct





**THIS PAGE IS LOCKED TO FREE MEMBERS**

Purchase full membership to immediately unlock this page

# DELVE INTO FANTASY, MAGIC, MYTHOLOGY & FOLKLORE

Forgotten Books'  
Full Membership gives  
access to 797,885 ancient  
and modern, fiction and  
non-fiction books.

**Continue**

\*Fair usage policy applies



the resistance of the air. Among these, the principal cause of the absorption of work which is to be considered here is the *friction*, of which we will first take up the general study before applying the laws to the particular case of the gearings.

### Friction.

**327.** When a body is moved by slipping on another body, there is produced a resistance which is opposed to the movement. This resistance is due to the action of the two surfaces in contact, when the movement already communicated to the body allows the inertia to be excluded. This resisting force is *friction*; it appears to proceed from the reciprocal action of the molecules of the two bodies. The inequalities of surface more or less evident in these bodies penetrate each other reciprocally, fit into each other with much greater intensity in proportion as the two bodies are more closely pressed together. Moreover, when one of these bodies is displaced the resistance produced by this "binding" is further increased by the driving back of the molecules situated in front of the moving body.

**328.** Besides this cause of resistance, there exists a second one, due to the *adhesion* of the two surfaces. The effect produced by this second cause can be made very apparent by placing on each other two planes of the same kind; if the surfaces are very carefully planed and perfectly polished, as, for example, those of two mirrors, the adhesion may become so great that the separation of the two bodies becomes very difficult.\*

Friction depends, therefore, on the two causes mentioned; but the last is very often neglected if the two surfaces are directly in contact, that is to say, if there is no coating or lubricating substance, such as oil, between these surfaces. Numerous experiments have, in fact, proven that this resistance may be neglected when the extent of the surfaces in contact is not very great.

**329.** But when one interposes a greasy substance between the two bodies, it is no longer possible to neglect this last cause, which, in certain cases, may diminish the friction properly speaking and, in others, increase it. We will treat, further on, of this question and will limit ourselves for the moment to the study of "dry friction."

---

\* This phenomenon arises from the more or less complete expulsion of the air between the surfaces and from the pressure of the exterior atmosphere.



**330. The Two Kinds of Friction.** If the same part of the surface of one of the rubbing bodies always remains in contact with the other body, there is sliding, and the friction takes the name of "sliding friction." If, on the contrary, the surfaces in contact change at each instant, there is rolling and the friction takes the name of "rolling friction." An example of the first case is the friction which is established during the movement of a sleigh along a road; and of the second case, that which is produced when a wheel rolls on a plane.

We will occupy ourselves especially with the sliding friction, the only kind which we will encounter in horology.

**331.** The slipping may be *linear*, that is to say, be effected along a plane or any surface whatever when one of the bodies is continually displaced with relation to the other; or it may be *circular*, if one of these bodies turns on itself without going forward, for example, a trunnion in its bearings.

The friction of the teeth of a gearing is produced by a linear slipping; that of the pivots of these same wheels in the interior of the holes in which they turn is produced by a circular slipping.

**332. Laws of Friction.** It has been discovered by very careful experiments that the resistance due to friction is subject to three principal laws which can guide in the applications and which are sufficiently exact within the limits between which they are considered in machines.

First—*The friction is proportional to the normal pressure*; that is to say, the resistance is always the same fraction of the pressure which applies one body on another, which is easily understood, since the actions of the molecules should arise by reason of this pressure.

Second—*The friction is independent of the surfaces in contact*; this is to say, when this extent increases without the pressure changing, the total resistance remains the same, although the pressure on each element of surface is found to be diminished in inverse relation to the extent of these surfaces. Since, for given substances, the friction is a constant fraction of the pressure, it follows that a heavy body drawn on a plane gives rise always to the same resistance, whatever may be the extent of the surface of contact.

Third—*The friction is independent of the speed of the movement*; which is to say, that the same amount of work is necessary



in overcoming the friction of a body traversing a certain distance, no matter what may be the speed which animates the body.

By the aid of these three fundamental laws and of the values determined, experimentally, in order to establish the relation of the friction to the pressure according to the nature of the surfaces in contact, one may value in each case the work absorbed by friction.

**333. Experimental Determination of the Force of Friction.** Let us suppose that a body with weight  $P$  be acted upon by a force  $F$  which makes it slide with a uniform movement on a surface  $AB$  (Fig. 96). One knows that when a body is moved uniformly,

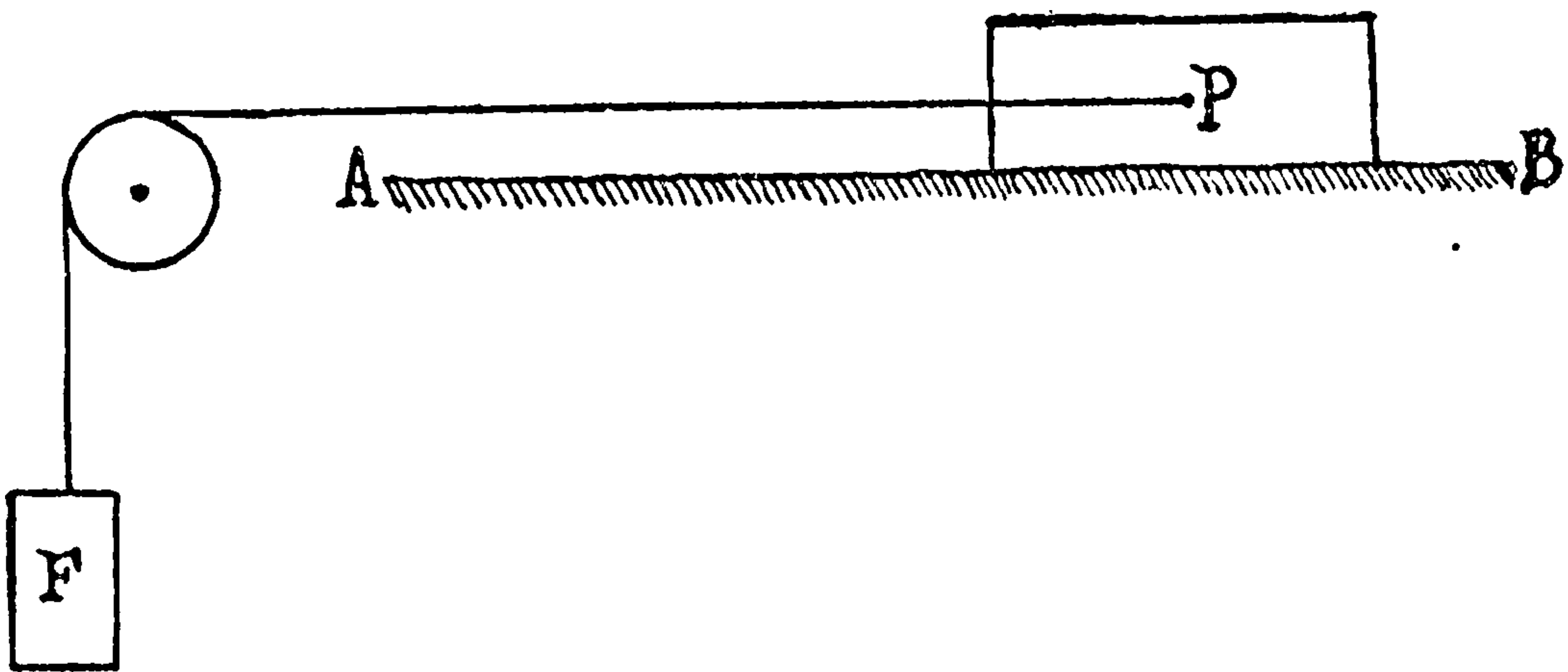

Fig. 96

the algebraic sum of the forces which act on this body is equal to zero. The force  $F$  should, therefore, be equal, and in contrary sense to, the force of friction; it will be, therefore, the measure of the greatness of this resistance.

One of the laws which we have cited, showing that the friction is proportional to the pressure, it follows that if the weight  $P$  is doubled, the friction is doubled at the same time and consequently its equivalent  $F$ .

The relation  $\frac{F}{P}$  is, therefore, constant for the same substances in contact; this is called the "coefficient of friction," that is generally represented in the calculations by the letter  $f$ . Thus one has

$$\frac{F}{P} = f.$$

When this coefficient is known, as well as the pressure  $P$  extended normally to the surfaces in contact, one can determine the friction  $F$  by multiplying the pressure  $P$  by the coefficient  $f$ . Therefore,

$$F = f P.$$

**334.** Let us note that the coefficient of friction does not always keep the same value for different surfaces of the same kind, for the





**THIS PAGE IS LOCKED TO FREE MEMBERS**

Purchase full membership to immediately unlock this page



# HISTORY

Tens of thousands of important historical sources, many previously unobtainable, are now available for the first time with a Forgotten Books Full Membership.

Unlimited Access  
\$8.99/month

**Continue**

\*Fair usage policy applies



In large machines whose frictioning parts are carefully greased the coefficient of friction diminishes to a value of  $f = 0.08$ .

**336. Work of Friction.** The mechanical work of a force being the product of this force by the path traversed by its point of application, when the path and the force have the same direction, one will have, if  $E$  is the path traversed,

$$W. F = f P E.$$

If the two bodies are movers, it will be necessary to consider the two forces of friction which have  $f P$  for common value and which act on each body in the inverse direction of its movement with regard to the other, each of the forces producing work.

Suppose that the movements of the two bodies  $A$  and  $B$  (Fig. 97) are effected in the direction of the arrows (1),  $E$  and  $E'$

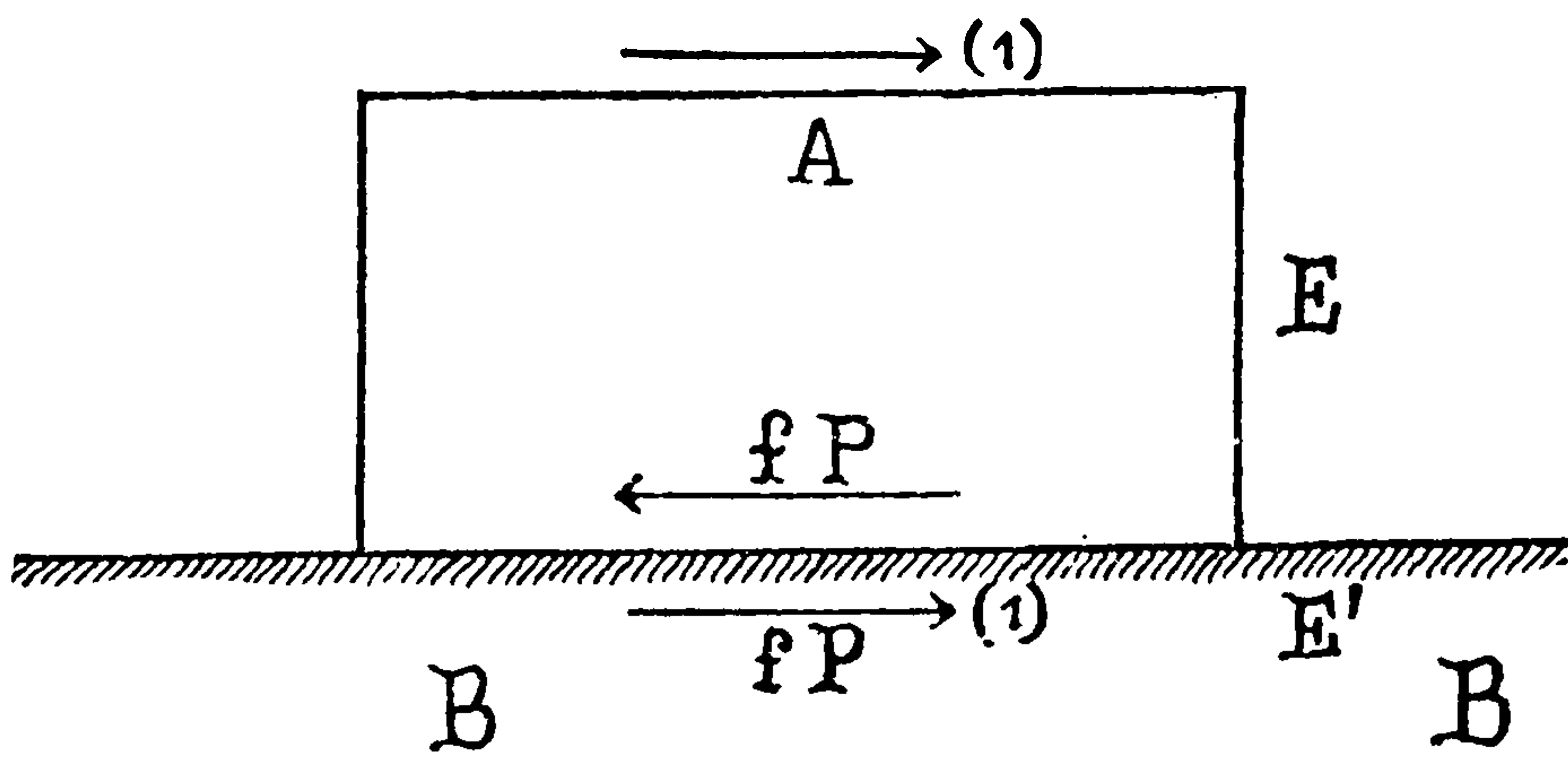

Fig. 97

being the respective paths traversed in this direction, which will be that of the relative movement of the body  $A$ , if  $E$  is greater than  $E'$ .

If we consider the movement of the body  $A$  the friction will produce a work  $f P. E.$ , which will be negative, since the direction  $f P$  is the inverse of that of  $E$ ; this is, therefore, a resisting work. On the contrary, the work of  $B$  on  $A$  will produce on this first body a positive work  $f P. E'.$ , which will take away from the resisting work  $f P. E.$ , so that finally the resisting work produced by the friction will be

$$W. F = f P. E - f P. E' = f P (E - E'),$$

$E - E'$  being positive. If  $E - E'$  becomes negative, the equation no longer holds, and the direction of the friction must be changed; in place of having  $f P (E - E')$ , one will have  $f P (E' - E)$ .

Let us here note that the work developed by the friction on one of the two bodies is positive; with regard to this body, therefore, friction plays the part of motive force. This property is employed industrially in the transmission of movement by cylinders, cones or friction plates.



**337. Angle of Friction.** Suppose a body resting on an inclined plane  $A C$  (Fig. 98); let us admit that we have regulated the inclination of this plane in such a manner that the body may be on the point of moving, or, what amounts to the same thing, that it is moved with a uniform motion, the length of this plane. In this case the force of the friction is equal and in a contrary direction to the force which acts to make it descend.

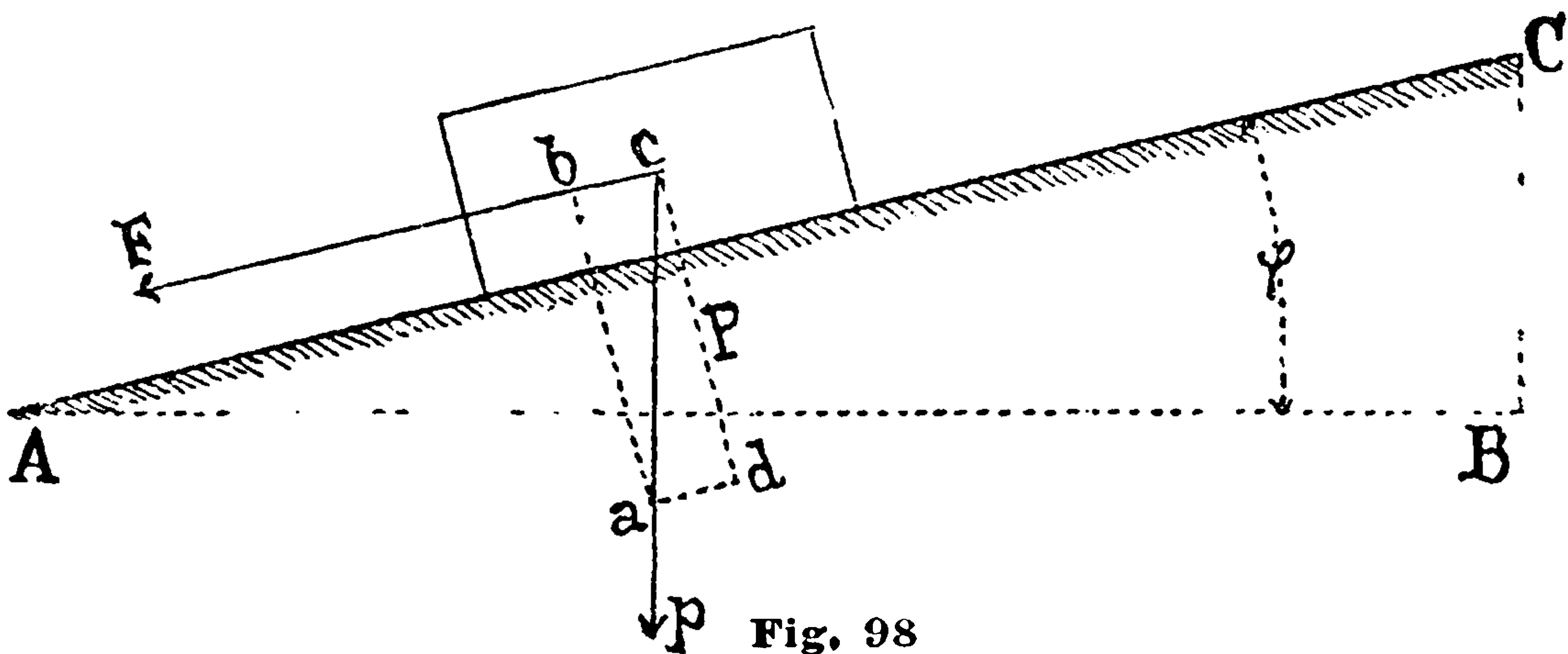

The weight  $p$  of the body acts along a vertical line  $ca$ , passing through its center of gravity; making  $ca = p$ , drawing the line  $cb$  parallel to the plane and  $cd$  perpendicular to this direction one will be able to form the parallelogram of the force by drawing the lines  $ad$  parallel to  $bc$  and  $ab$  parallel to  $cd$ . The length  $cb$  will then represent the value of the force  $F$  tending to make the body descend along the plane, and the length,  $cd$ , the normal pressure  $P$ . We will, therefore, have

$$\frac{bc}{ca} = \frac{F}{P}.$$

The similar triangles  $bca$  and  $BCA$  give, moreover, the proportion

$$\frac{bc}{ca} = \frac{BC}{BA} = \frac{F}{P} = f.$$

One can thus see that the coefficient of friction is equal to the quotient of the height  $BC$  of the inclined plane divided by the length of the base  $AB$ .

**338.** Designating by  $\phi$ , the angle,  $CAB$ , that the inclined plane forms with the horizon when the movement takes place, the two components of the weight  $p$  can also be represented by

$$p \sin \phi = F$$

following the direction of the inclined plane and by

$$p \cos \phi = P$$



perpendicularly to this plane. One has, therefore,

$$\frac{F}{P} = \frac{p \sin \phi}{p \cos \phi} = \text{tang } \phi = f.$$

One discovers, on varying arbitrarily the extent of the surface in contact and the weights of the bodies, that the angle of inclination does not vary for the same substances in contact.

This angle is called the *angle of friction* and the numerical value of the relation of the friction to the pressure, equal to  $\text{tang. } \phi$ , is the coefficient of the friction. For hard and polished metals and the stones used in horology, this angle has a value varying from  $7^\circ$  to  $8^\circ 30'$ .

EXAMPLE OF APPLICATION.—On a plate of tempered and polished steel we place a ruby, a lever pallet, for example. We elevate little by little one of the extremities of the plate until the ruby commences to slide with a uniform movement. The height  $BC$  to which it was necessary to elevate the steel plate being 13.4 mm. and the length of the base  $AC$  89 mm., the coefficient of friction of the ruby on the steel should be

$$f = \frac{13.4}{89} = 0.15.$$

The angle of friction will be, in this case,

$$\begin{aligned} \text{tang. } \phi &= 0.15 \\ \text{and } \phi &= 8^\circ 32', \end{aligned}$$

value that we will adopt in our calculations.

#### Calculation of the Friction in Gearings.

339. Knowing the normal pressure between the teeth of a gearing, one has the value of the sliding friction (333), so that if one knows the length of the space traversed by the friction of one tooth on another, one would have the work absorbed by this friction (336).

Before entering into the details of this calculation, let us recall the kinetic question of the transmission of the movement.

We have found that by means of gearings, the movement of one wheel is uniformly transmitted to another; this geometrical demonstration is independent of the material of which the wheels are formed, of the nature of the friction, etc. This property holds good whatever may be the friction in play and the greatness of the efforts which are shown. The passive resistances have, therefore, no effect on the transmission of the movement, properly speaking; they only increase





**THIS PAGE IS LOCKED TO FREE MEMBERS**

Purchase full membership to immediately unlock this page

# DELVE INTO FANTASY, MAGIC, MYTHOLOGY & FOLKLORE

Forgotten Books'  
Full Membership gives  
access to 797,885 ancient  
and modern, fiction and  
non-fiction books.

**Continue**

\*Fair usage policy applies



point of contact is very slightly removed from the arc  $t c'$ , one can suppose, without committing an appreciable error, that the pressure is equal to the force  $Q$  acting tangentially to  $t c'$ , and the work absorbed is, therefore,

$$a Q.$$

From the hypothesis that the normal pressure between the teeth is constantly equal to  $Q$  (mean value of this pressure), it follows that the friction is equal to

$$f Q.$$

As to the work absorbed by this friction, one remarks that while the point of contact  $t$  passes to  $t'$ , the space traversed by this point on the tooth which controls is equal to  $t' c$  and that which it has traversed on the controlled wheel is  $t' c'$ , from whence it follows that there has been sliding on a length equal to

$$t' c - t' c',$$

a difference which one can suppose equal to a straight line joining  $c$  to  $c'$ . The work absorbed by the friction is, therefore,

$$Q f \times c c'.$$

Dropping the perpendiculars  $c e$  and  $c' e'$  to the line of centers,  $O O'$  being almost parallel to  $c c'$ , one can suppose

$$c c' = e e' = t e + t e',$$

but, one has

$$t e = \frac{\overline{c t^2}}{2 r} \text{ and } t e' = \frac{\overline{c' t'^2}}{2 r'}; *$$

and since one can admit  $c t = c' t = a$ ,

which comes nearer the truth as the pitch becomes smaller with relation to the radius, one has, therefore,

$$t e = \frac{a^2}{2 r} \text{ and } t e' = \frac{a^2}{2 r'};$$

consequently the work absorbed by the friction is

$$Q f \left( \frac{a^2}{2 r} + \frac{a^2}{2 r'} \right) = Q \frac{f a^2}{2} \left( \frac{1}{r} + \frac{1}{r'} \right).$$

The work which the wheel  $A$  should transmit to the wheel  $A'$  for the distance traversed  $a$  is, therefore,

$$W_m = Q a + Q a \frac{f a}{2} \left( \frac{1}{r} + \frac{1}{r'} \right). \quad (1)$$

\*A chord is the mean proportional between the diameter and its projection on this diameter.



If  $P$  is the motive force which acts tangentially on the driving wheel, the motive work for the distance traversed  $a$  is  $P a$  and one has

$$P a = Q a + Q a \frac{f a}{2} \left( \frac{1}{r} + \frac{1}{r'} \right),$$

from whence

$$P = Q + Q \frac{f a}{2} \left( \frac{1}{r} + \frac{1}{r'} \right).$$

**341.** Taking up again the formula (1) in which  $Q a$  represents the useful work " $W_u$ ," this can still be put under the form

$$W_m = W_u + W_u \cdot \frac{f a}{2} \left( \frac{1}{r} + \frac{1}{r'} \right). \quad (2)$$

Since one has, moreover,

$$\frac{r}{r'} = \frac{n}{n'},$$

$n$  and  $n'$  being the number of teeth, and since

$$n a = 2 \pi r \text{ and } n' a = 2 \pi r',$$

one obtains

$$r = \frac{n a}{2 \pi} \text{ and } r' = \frac{n' a}{2 \pi}.$$

On replacing these values in the formula (2) and simplifying, it becomes

$$W_m = W_u + W_u \cdot f \pi \left( \frac{1}{n} + \frac{1}{n'} \right), \quad (3)$$

or

$$W_m = W_u \left[ 1 + f \pi \left( \frac{1}{n} + \frac{1}{n'} \right) \right],$$

from whence one draws

$$W_u = \frac{W_m}{1 + f \pi \left( \frac{1}{n} + \frac{1}{n'} \right)}. \quad (4)$$

**342.** On examining these two last equations, we can see that one diminishes the friction by increasing the number of teeth.

Thus, for a wheel of 64 teeth gearing in a pinion of 8 leaves, one would have, on admitting  $W_m = 1$  and  $f = 15$ ,

$$W_u = \frac{1}{1 + 0.15 \cdot 3.1416 \left( \frac{1}{64} + \frac{1}{8} \right)} = \frac{1}{1.066},$$

while for a wheel of 96 teeth gearing in a pinion of 12 leaves, one would have only

$$W_u = \frac{1}{1 + 0.15 \cdot 3.1416 \left( \frac{1}{96} + \frac{1}{12} \right)} = \frac{1}{1.044}.$$



One thus discovers the practical rule that the number of teeth must be increased as much as possible in order to diminish the work of friction, to have less wear and a smoother motion.

343. For *interior gearings*, the formulas (3) and (4) become

$$W_m = W_u + W_u f \pi \left( \frac{1}{n} - \frac{1}{n'} \right) \quad (5)$$

and

$$W_u = \frac{W_m}{1 + f \pi \left( \frac{1}{n} - \frac{1}{n'} \right)}. \quad (6)$$

One sees that in these gearings, with the same number of teeth the friction is less than in the exterior gearings.

344. The friction in the *rack* can also be deduced from the preceding formulas, on remarking that the radius of one of the primitive circumferences becoming infinite the general expression of the friction, for  $n = \infty$ , becomes

$$W_m = W_u + W_u f \pi \frac{1}{n'}, \quad (7)$$

and

$$W_u = \frac{W_m}{1 + f \pi \frac{1}{n'}}. \quad (8)$$

345. For *conical gearings*, on preserving the same relations as in the preceding cases, one would arrive at the following results,  $\alpha$  being the angle formed between the axes of the two wheels :

$$W_m = W_u + W_u \frac{f a}{2} \sqrt{\frac{1}{r^2} + \frac{1}{r'^2} + \frac{2 \cos \alpha}{r r'}} \quad (9)$$

and

$$W_u = \frac{W_m}{1 + f \pi \sqrt{\frac{1}{n^2} + \frac{1}{n'^2} + \frac{2 \cos \alpha}{n n'}}}. \quad (10)$$

These gearings are smoother than cylindrical gearings of the same number of teeth.

346. **Friction Before and After the Line of Centers.** In the formulas which we have established, the influence of the friction is the same before as after the line of centers ; this result does not agree with those of experience, which show, on the contrary, that the friction before the line of centers is more hurtful than that which is exerted after the passage of this line. However, since we have supposed the pitch as being very small, our results can be considered, in this case, as sufficiently exact.

It is certain that it would no longer be the same if the contact commenced at a relatively great distance from the line of centers.





**THIS PAGE IS LOCKED TO FREE MEMBERS**

Purchase full membership to immediately unlock this page



# HISTORY

Tens of thousands of important historical sources, many previously unobtainable, are now available for the first time with a Forgotten Books Full Membership.

Unlimited Access  
\$8.99/month

**Continue**

\*Fair usage policy applies



moment of the force with relation to the axis of the wheel which drives, and  $Q$  the moment of the force with relation to the axis of the wheel which is driven.

The wheel  $O$  is in equilibrium under the action of the force  $P$ , whose moment is  $P$ , of the normal force  $N' = N$  whose moment is  $-N \cdot O b$  and of the force of friction  $f N$ , directed perpendicularly to the normal force, and whose moment is  $-f N \cdot O d$ . One has, therefore,

$$P - N O b - f N O d = 0.$$

On the other hand, the wheel  $O'$  is in equilibrium under the action of the force  $Q$ , whose moment is  $Q$  and of the normal reaction  $N' = N$  whose moment is  $-N' \cdot O' b'$ . The moment of the force of friction is null, since its lever arm is equal to zero. One has, therefore,

$$Q - N \cdot O' b' = 0.$$

On dividing the first of these equations by the second and simplifying, one obtains

$$\frac{P}{Q} = \frac{O b + f \cdot O d}{O' b'}$$

But, on designating by  $\beta$  the angle  $b t O = b' t O'$  formed by the normal and the line of centers, one will also have

$$\frac{P}{Q} = \frac{r \cdot \sin \beta + f (r + r') \cos \beta}{r' \cdot \sin \beta},$$

and, on dividing by  $\sin \beta$ ,

$$\frac{P}{Q} = \frac{r}{r'} \left( 1 + f \frac{r + r'}{r} \cotang \beta \right),$$

or also

$$\frac{P r'}{Q r} = 1 + f \left( 1 + \frac{r'}{r} \right) \cotang \beta. \quad (1)$$

Let us remark that if, in this equation, we make the friction equal to zero, we will have

$$\begin{aligned} \text{or} \quad \frac{P r'}{Q r} &= 1 \\ \frac{P}{Q} &= \frac{r}{r'}, \end{aligned}$$

an analogous formula to that which we have established (196, equa. 17).

If, in the above formula (1), one places  $Q r = 1$ , one will obtain for  $P r'$  a value superior to unity.

The angle  $\alpha$  (Fig. 100) which the leaf is diverted from the line of centers, is the complement of  $\beta$ ; one can, therefore, also write the equation (1) :

$$\frac{P r'}{Q r} = 1 + f \left( 1 + \frac{r'}{r} \right) \tang \alpha.$$



NUMERICAL CALCULATION.—Let  $Q r = 1$ ,  $f = 0.15$ ,

one has 
$$\frac{n'}{n} = \frac{6}{60}, \quad \alpha = 42^\circ 15' 47'',$$

$$f \left( 1 + \frac{n'}{n} \right) = 0.15 \left( 1 + \frac{6}{60} \right) = 0.165$$

$$\text{Log : } 0.165 = 0.2174839 - 1$$

$$\text{Log : } \text{tang } \alpha = 9.9584454$$

$$\hline 0.1759293 - 1$$

$$\text{Number . . .} = 0.14994$$

We will therefore have the relation

$$\frac{P r'}{Q r} = 1.14994.$$

On subtracting the friction, and admitting the moment  $P = 1$  gr., we would have, in this case,

from whence 
$$\frac{P}{Q} = \frac{60}{6},$$

$$Q = 1 \cdot \frac{6}{60} = 0.1 \text{ gr.}$$

On introducing the force of friction, one will have

from whence 
$$\frac{P}{Q} = \frac{1.14994 \times 60}{6},$$

$$Q = \frac{1}{11.4994} = 0.08696 \text{ gr.}$$

### 349. The Pinion Drives the Wheel Before the Line of Centers.

In this case the moment  $Q$  becomes the moving power and the value  $Q r$  will become superior to  $P r'$ . The formula (1) then becomes

$$\frac{Q r}{P r'} = \frac{1}{1 - f \left( 1 + \frac{n'}{n} \text{ tang } \alpha \right)}, \quad (2)$$

remarking that the sign of the friction is changed.

NUMERICAL CALCULATION.—The same data as in the preceding case, except that we take here  $P r = 1$ . We have

$$f \left( 1 + \frac{n'}{n} \right) \text{ tang. } \alpha = 0.14994,$$

then 
$$1 - f \left( 1 + \frac{n'}{n} \right) \text{ tang. } \alpha = 0.85006,$$

$$\frac{Q r}{P r'} = \frac{1}{0.85006} = 1.1764.$$



On subtracting the friction, one would have, if  $Q = 1$  gr.,

$$\text{from whence } \frac{Q}{P} = \frac{6}{60},$$

$$P = Q \frac{60}{6} = 10 \text{ gr.}$$

On introducing the force of friction, one will have

$$\text{from whence } \frac{Q}{P} = 1.1764 \frac{6}{60},$$

$$P = \frac{1}{0.11764} = 8.5 \text{ gr.}$$

### 350. The Wheel Drives the Pinion Before the Line of Centers.

We have in this case (Fig. 101), reasoning the same as in the preceding cases,

$$\begin{aligned} P - N. O b &= 0. \\ Q - N'. O' b' + f N'. O' d &= 0. \end{aligned}$$

from whence

$$\begin{aligned} \text{or, again, } \frac{P}{Q} &= \frac{r. \sin \beta}{r'. \sin. \beta - f (r + r') \cos \beta}; \\ \frac{P r'}{Q r} &= \frac{1}{1 - f \left( 1 + \frac{n}{n'} \right) \cotang \beta}. \end{aligned}$$

But the angle  $b O O'$ , complement of  $\beta$ , is equal to

$$\alpha \frac{n'}{n},$$

since the angles traversed in the same time by the two mobiles of a gearing are inversely proportional to the numbers of teeth (176). One will, therefore, have,

$$\frac{P r'}{Q r} = \frac{1}{1 - f \left( 1 + \frac{n}{n'} \right) \tang \left( \alpha \frac{n'}{n} \right)} \quad (3)$$

NUMERICAL CALCULATION.—Let  $\alpha = 17^\circ 44' 13''$ ,  $n = 60$ ,  $n' = 6$ .

One has

$$\alpha \frac{n'}{n} = 0.1 \times 17^\circ 44' 13'' = 1^\circ 46' 25.3''$$

$$f \left( \frac{n'}{n} + 1 \right) = 0.15 \times 11 = 1.65$$

$$\log. 1.65 = 0.2174839$$

$$\log. \tang. \left( \alpha \frac{n'}{n} \right) = 8.4908948$$

$$\hline 0.7083787 - 2$$

$$\text{Number} = 0.051095$$





**THIS PAGE IS LOCKED TO FREE MEMBERS**

Purchase full membership to immediately unlock this page

# DELVE INTO FANTASY, MAGIC, MYTHOLOGY & FOLKLORE

Forgotten Books'  
Full Membership gives  
access to 797,885 ancient  
and modern, fiction and  
non-fiction books.

**Continue**

\*Fair usage policy applies



**351. The Pinion Drives the Wheel After the line of Centers.**

The moment  $Q$  becomes the moving power and the formula (3)

becomes 
$$\frac{Q r}{P r'} = 1 + f \left( 1 + \frac{n}{n'} \right) \text{tang.} \left( \alpha \frac{n'}{n} \right) \quad (4)$$

on changing the sign of the friction.

NUMERICAL CALCULATION.—One has, from the preceding calculation,

$$\frac{Q r}{P r'} = 1 + 0.051095 = 1.051095.$$

Without the friction, we will have

$$\frac{Q}{P} = \frac{n'}{n},$$

from whence

$$P = Q \frac{n}{n'},$$

and if  $Q = 1$  gr.,

$$P = \frac{60}{6} = 10 \text{ gr.}$$

With the friction, one will have

$$P = \frac{60}{6} \cdot \frac{1}{1.051095} = \frac{10}{1.051095}$$

and  $P = 9.514$  gr.

**352. Recapitulation of the Preceding Calculations.**

The moment of the motive force acting on the wheel being equal to 1 gramme, the moment of the resisting force with relation to the axis of the pinion should be at the instant of the first contact before the line of centers,

$$Q = 0.09489 \text{ gr.};$$

and at the instant of the last contact after the line of centers,

$$Q = 0.08696 \text{ gr.}$$

When the pinion drives the wheel, we have found at the instant of the first contact before the line of centers,

$$P = 8.5 \text{ gr.},$$

and at the instant of the last contact after the line of centers,

$$P = 9.514 \text{ gr.}$$

One sees that, in the most usual case, when the wheel drives the pinion, the force absorbed by the friction before the line of centers differs very little from that which is absorbed after the passage of this line, which confirms what we have admitted (261).\*

\* In order to be able to compare them in an absolute manner, the above figure should be calculated for angles of approach and retreat equal to each other. Which explains why, when the wheel drives the pinion, the moment of the force absorbed by the friction before the line of centers is inferior to that which we have obtained for the instant of the last contact. If one calculated, for the above case, the moment of the force  $Q$  for an angle of retreat,  $17^{\circ} 44' 13''$ , one would find

$$Q = 0.09498 \text{ gr.},$$

a figure very little greater than that which we have obtained for the same angle before the line of centers.



One sees also that the smaller the driving wheel becomes with relation to the one which is driven, the more also increases the difference of the resistance before and after the line of centers ; the numbers of teeth of the two mobiles should, therefore, be increased as much as possible.

### Calculations of the Friction of Pivots.

**353.** When the watch is placed in a horizontal position, the different mobiles of the train rest on the flat "shoulders" of their

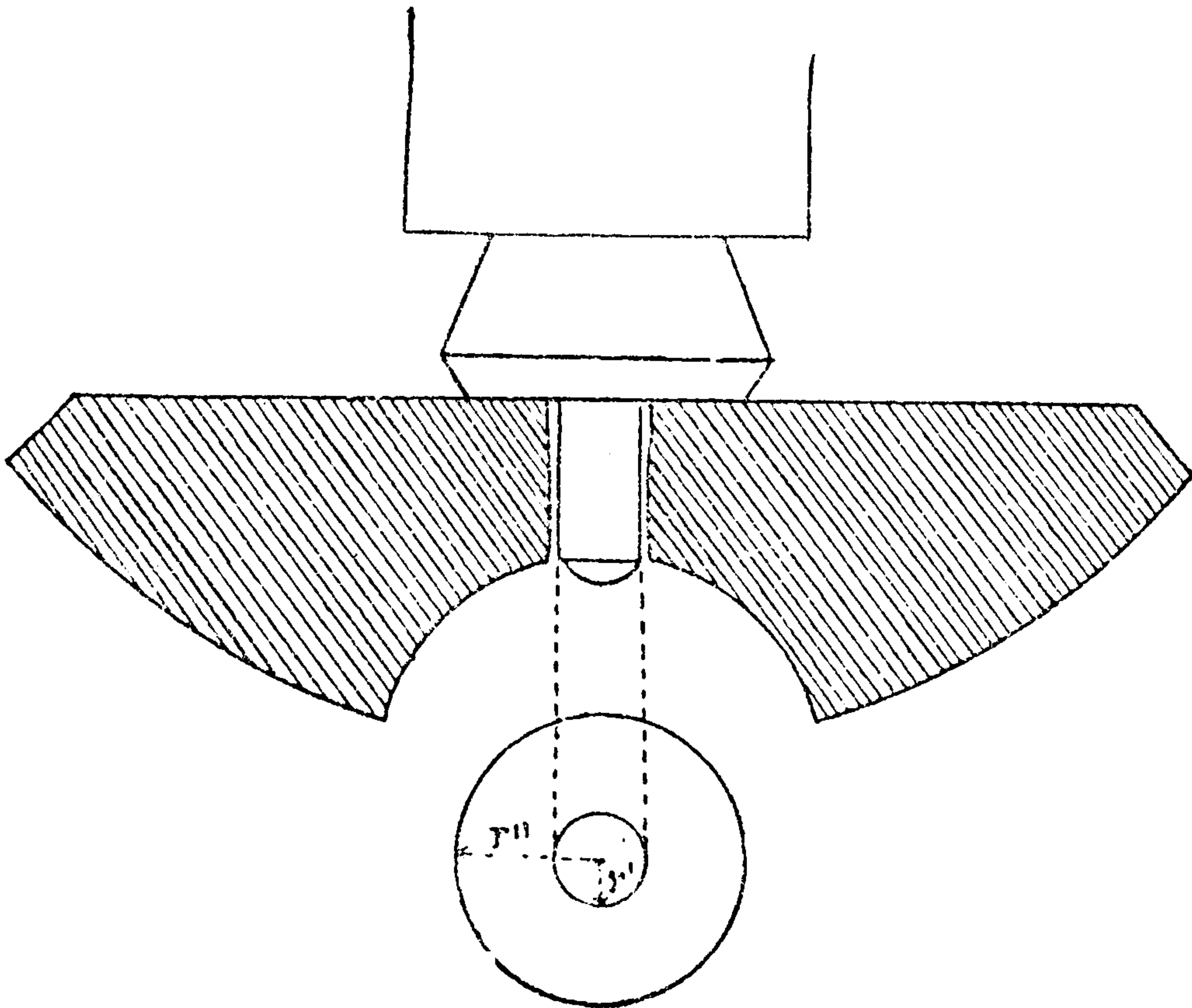

Fig. 102

lower pivots ; in the vertical position, these same mobiles rest on the cylindrical surfaces of the two pivots. The force of friction is proportionate to the pressure which the surfaces in contact undergo. In the horizontal positions, the pressure proceeds from the weight of the mobile and from the lateral force which presses the pivots against the sides of the holes ; in the vertical positions, these same forces are in action, but on account of the position of the gearing on the axes, these pressures will generally be different on each pivot.

**354. Work Absorbed by Friction on the Plane Surface of the Shoulder of a Pivot.** Suppose (Fig. 102)  $r''$  the exterior radius of the shoulder and  $r'$  the radius of the pivot. Representing also the mean radius  $\frac{r'' + r'}{2}$  by  $\delta$  and the width of the shoulder by  $l$ , then  $l = r'' - r'$ .



One will have, consequently,

$$r'' = \delta + \frac{l}{2} \text{ and } r' = \delta - \frac{l}{2}.$$

The surface of the circular crown with radius  $r'' - r'$  being

$$\pi (r''^2 - r'^2),$$

one will have

$$\pi (r''^2 - r'^2) = \pi \left[ \left( \delta + \frac{l}{2} \right)^2 - \left( \delta - \frac{l}{2} \right)^2 \right] = 2 \pi \delta l.$$

The surface of the circle with radius  $r'$  will be

$$\pi r'^2 = \pi \left( \delta - \frac{l}{2} \right)^2 = \pi \left( \delta^2 + \frac{l^2}{4} - \delta l \right),$$

$P$  being the pressure exerted on the crown and admitting that this pressure varies proportionately to the extent of the surface; that which is exerted on a circle with radius  $r'$  should be

$$\frac{P}{2 \delta l} \left( \delta^2 + \frac{l^2}{4} - \delta l \right),$$

and that which would take place on the circle with radius  $r''$  would be

$$P + \frac{P}{2 \delta l} \left( \delta^2 + \frac{l^2}{4} - \delta l \right).$$

The work absorbed by the friction of the crown is equal to the work absorbed by the friction which would be produced on the total surface of the circle with radius  $r'' = \delta + \frac{l}{2}$  diminished by that which would take place on the surface of the circle with radius  $r' = \delta - \frac{l}{2}$ ; it is, therefore,\*

$$W = \frac{4}{3} \pi f \left[ P \left( \delta + \frac{l}{2} \right) + P \frac{\delta^2 + \frac{l^2}{4} - \delta l}{2 \delta l} \left( \delta + \frac{l}{2} \right) - P \frac{\delta^2 + \frac{l^2}{4} - \delta l}{2 \delta l} \left( \delta - \frac{l}{2} \right) \right]$$

or

$$W = \frac{4}{3} \pi f P \left\{ \delta + \frac{l}{2} + \frac{\delta^2 + \frac{l^2}{4} - \delta l}{2 \delta l} \left[ \left( \delta + \frac{l}{2} \right) - \left( \delta - \frac{l}{2} \right) \right] \right\};$$

\*For a pressure  $P$ , the force developed by friction is  $f P$ ; the work of this force is the product of  $f P$  by the distance traversed. This distance is not the same for all the points of the surface: null at the center, it attains its maximum at the exterior circumference. To obtain its mean value, divide the circle with radius  $r$  into a number  $n$  of equal sectors sufficiently small so that each of them can be regarded as a triangle. The resultant of the elementary pressures supported by each of these triangles should pass through its center of gravity, say, at  $\frac{2}{3}$  of the radius. The force of friction being for one of them  $f \frac{P}{n}$ , the work of this force will be, for one revolution,

$$f \frac{P}{n} \cdot 2 \pi \frac{2}{3} r = f \frac{P}{n} \cdot \frac{4}{3} \pi r,$$

and for the sum of the  $n$  sectors, the work will be

$$W = \frac{4}{3} f P \pi r.$$





**THIS PAGE IS LOCKED TO FREE MEMBERS**

Purchase full membership to immediately unlock this page



# HISTORY

Tens of thousands of important historical sources, many previously unobtainable, are now available for the first time with a Forgotten Books Full Membership.

Unlimited Access  
\$8.99/month

**Continue**

\*Fair usage policy applies



resultant of the partial forces that the axis of the wheel receives at each of its extremities. This pressure depends on the relation of the distance of the pivots from the point of application of the forces in play to the length of the axis.

**358.** Let us imagine the point of contact of the teeth and of the leaves on the line of centers and let us represent by  $P$  the force that the leaf of the pinion receives on the part of the wheel tooth of the center wheel; since, simultaneously with this, one wheel tooth of the third wheel is pressed against a pinion leaf of the fourth wheel, the force  $P$  gives birth to the reaction  $P'$ . The direction of the forces  $P$  and  $P'$  is perpendicular to the line of centers.

Let us call  $r$  and  $r'$  the primitive radii of the wheel and pinion, we will have for the state of equilibrium

$$P r' = P' r \text{ and } P' = P \frac{r'}{r}.$$

The equilibrium will not be disturbed if one will apply to the point diametrically opposed to that of the contact of the tooth and leaf a force  $P_1$  equal, and in a contrary direction, to  $P$  and, likewise, at the point opposite to the point of application of  $P'$ , a force  $P'_1$  equal and in a contrary direction to this one.

The resultant of the forces  $P$  and  $P_1$  is  $2 P$ ; it should be applied at the axis of the pinion, parallelly to the components (Fig. 103).

The top pivot of the third wheel will receive on the part of the resultant  $2 P$  a force  $p$  and the lower pivot a force  $q$  in such a way that one would have

$$2 P = p + q.$$

One should have

$$p a = q b,$$

$a$  representing the distance of the shoulder of the top pivot from the middle of the thickness of the center wheel, and  $b$  the distance from this last point to the shoulder of the lower pivot.

To determine the values  $p$  and  $q$ , we extract from the first formula

$$q = 2 P - p,$$

from whence, on substituting this value in the second,

$$p a = 2 P b - p b$$

and

$$p = 2 P \frac{b}{a + b}.$$

In an analogous manner, one has

$$q = 2 P \frac{a}{a + b}.$$







The pivots receive, moreover, an action from the forces  $P'$  and  $P'_1$ , whose resultant is  $2 P'$ , and we will have

$$2 P' = p' + q',$$

$p'$  and  $q'$  being the strains received by each pivot on the part of  $2 P'$ .

One will thus have

$$p' = 2 P' \frac{e}{a + b}$$

and

$$q' = 2 P' \frac{d}{a + b}$$

on remarking that  $d + e = a + b$ .

Since

$$P' = P \frac{r'}{r},$$

one will also write

$$p' = 2 P \frac{r'}{r} \cdot \frac{e}{a + b} \text{ and } q' = 2 P \frac{r'}{r} \cdot \frac{d}{a + b}.$$

The top bridge receiving, therefore, the two forces  $p$  and  $p'$ , their common resultant will be, in magnitude and in direction, the diagonal of the parallelogram constructed with these lines as sides.

Let us notice that since we have added to  $P$  and  $P'$  the forces  $P_1$  and  $P'_1$  equal each to each, the real resultant  $R$  should be half of that which is thus determined.

To calculate this value, let us represent by  $\alpha$  the angle formed by the lines from the centers having their meeting point at  $O$ ; we will thus have the angle  $O B A$  equal also to  $\alpha$ . We will have in the triangle  $O B A$ ,  $O B = p'$  and  $B A = p$ , since  $O A = 2 R$ ; therefore,

$$2 R = \sqrt{p^2 + p'^2 - 2 p p' \cos \alpha},$$

or, on replacing  $p$  and  $p'$  by the half of their value, one obtains

$$R = \sqrt{P^2 \left( \frac{b}{a + b} \right)^2 + \left( P' \frac{r'}{r} \cdot \frac{e}{a + b} \right)^2 - 2 P^2 \frac{b}{a + b} \cdot \frac{r'}{r} \cdot \frac{e}{a + b} \cos \alpha},$$

or

$$(1) \quad R = \frac{P}{a + b} \sqrt{b^2 + \left( \frac{r'}{r} \cdot e \right)^2 - 2 e b \frac{r'}{r} \cdot \cos \alpha}.$$

For the lower pivot, one would obtain in an analogous manner

$$(2) \quad R_1 = \frac{P}{a + b} \sqrt{a^2 + \left( \frac{r'}{r} \cdot d \right)^2 - 2 a d \frac{r'}{r} \cdot \cos \alpha}.$$

**359.** Upon examining the Fig. 103, one will notice that the pressure of the center wheel teeth is greater than the resistance which the leaves of the third pinion oppose. Consequently, for





**THIS PAGE IS LOCKED TO FREE MEMBERS**

Purchase full membership to immediately unlock this page

# DELVE INTO FANTASY, MAGIC, MYTHOLOGY & FOLKLORE

Forgotten Books'  
Full Membership gives  
access to 797,885 ancient  
and modern, fiction and  
non-fiction books.

**Continue**

\*Fair usage policy applies



We will have for the top pivot

$$\frac{P}{a+b} = \frac{77.5}{4.86} = 15.95 \cdot \frac{r'}{r} = \frac{0.87}{5.49} = 0.16,$$

and

$$b^2 = 4.06^2 = 16.40. \quad \left(\frac{r'}{r} e\right)^2 = (0.16 \times 2.2)^2 = 0.1239.$$

$$2 a d \frac{r'}{r} \cdot \cos \alpha = 2 \times 2.2 \times 4.06 \times 0.16 \times -0.08715 = -0.25.$$

and

$$R = 15.95 \sqrt{16.48 + 0.1239 + 0.25}$$

$$R = 15.95 \sqrt{16.8539} = 65.47.$$

For the lower pivot, one will have successively

$$R_1 = 15.95 \sqrt{0.8^2 + 0.16 \times 3.2^2 - 2 \times 0.8 \times 0.32 \times 0.16 \times \cos 95^\circ}$$

and

$$R_1 = 15.95 \sqrt{0.64 + 0.26 + 0.07}$$

$$R_1 = 15.95 \sqrt{0.97} = 15.71.$$

**365.** Let us now determine the value of the work of friction of the third wheel's pivots during one oscillation of the balance. We have the formula (356).

$$W. F = f P r_1 \beta,$$

in which  $P$  represents the pressure,  $r_1$  the pivot's radius,  $\beta$  the angle traversed during one oscillation.

Let us first seek this latter angle. The fourth wheel makes one rotation in 60 seconds or in 300 oscillations. If the third wheel has 75 teeth and the fourth pinion 10 leaves, this pinion turns 7.5 times faster than the third wheel; the third wheel, therefore, makes one turn in  $300 \times 7.5$  oscillations = 2250 oscillations.

During one oscillation it will traverse, therefore, an angle  $\beta$ :

$$\beta = \frac{360^\circ}{2250} = 0^\circ 9' 36'';$$

this angle expressed in length of arc with radius equal to unity is

$$\text{or} \quad 0^\circ 9' 36'' = 0.00279$$

0.0028 in round numbers.

The diameter of the pivots being 0.26, we will have for the top pivot

$$W. F = 0.15 \times 65.47 \times 0.13 \times 0.0028 = 0.0035 \text{ gr. mm.}$$

and for the lower pivot

$$W. F = 0.15 \times 15.71 \times 0.13 \times 0.0028 = 0.00085 \text{ gr. mm.}$$



The total work absorbed by the friction will, consequently, be

$$W. F = 0.0035 + 0.00085 = 0.00435 \text{ gr. mm.}$$

The work of the motive force applied to this wheel being 0.21 gr. mm. during the duration of one oscillation of the balance, one can prove that the work absorbed by the friction of the pivots represents about the fiftieth part of it.

#### Influence of the Oil.

**366.** We have said at the beginning of the study of friction that the introduction of a greasy substance between the frictioning surfaces of two bodies, compelled to slide on each other, is necessary in all cases where a heating and consequently grinding and wear are to be feared.

When greasy substances are interposed between two surfaces, these are no longer in immediate contact, the molecules of grease form little spheres which roll between the two bodies. In most cases, especially in large mechanisms, the friction will be reduced by this fact.

In horology, especially in pocket watches, the inverse phenomenon can present itself. The oil which is used introduces a new resistance, an adhesion, or, otherwise expressed, a "sticking." This new resistance is added to the friction and it can happen that the coefficient of the sum of the two resistances may be greater than the coefficient of dry friction. With regard to the weak forces in action on the last mobiles of the train, on those of the escapement and on the balance, this last resistance cannot be neglected. Unfortunately, it is very difficult to express this force in figures, because it depends on the nature of the lubricant, on its degree of fluidity and on its unchangeableness.

The friction which is exerted through the agency of a lubricant depends on the speed of the bodies in contact, and on the extent of their surfaces. It depends also on the nature of the movement; thus, it is different on an annular balance when the latter is animated with a continuous circular movement and when it is animated with an oscillatory movement (circular reciprocating). One understands, in this latter case, that a certain quantity of oil participates in the movement of the pivots and that this oil would have a tendency to continue in the direction of the movement, although the pivots turn already in the opposite direction.



In all the experiments relative to the friction of lubricated bodies, care must be taken to assure oneself that the lubricants are neither altered nor expelled.

One can take as a general principle that the best lubricant is that which is the most fluid, that is to say, it is better, when one can, to replace grease by oil, oil by water, water by air, which is equivalent to suppressing all lubricants. This supposes that the speed of the mobiles may be sufficiently great not to expell the lubricant experimented with. But a considerable speed is necessary for the pieces to retain a fluid lubricant like water and with still much more reason for them to leave between themselves a sufficient cushion of air. Experiments have been made with the astonishing result of showing the friction almost suppressed between two pieces rubbing together without any lubricant and at an enormous speed.\*

This almost entire disappearance of friction is due to the interposition of a cushion of air, a perfectly elastic matter, between the surfaces in contact.

In horology, in all cases where the use of a lubricant is necessary, one must, therefore, take into account the speed of the mobiles and the pressure which they have to support. Thus, the wheels of the stem-winding mechanism should always be greased by means of a semi-fluid lubricant.†

The motive spring, as well as the pivots of the arbor around which the barrel turns, should be lubricated with a thicker oil than that which one employs for the train and the escapement.

The principal qualities of the refined oil which is used in horology should be its unchangeableness by the atmosphere and by the various temperatures which the watch must stand, its perfect fluidity and the absence of acids in its composition. The solution of this question so important to the preserving, for the longest possible time, of the precision in the running of chronometrical instruments, lies within the domain of organic chemistry.

---

\* Hirn's experiments.

† Practical men value highly for these mobiles, a mixture of pure white wax and refined animal oil.





**THIS PAGE IS LOCKED TO FREE MEMBERS**

Purchase full membership to immediately unlock this page



# HISTORY

Tens of thousands of important historical sources, many previously unobtainable, are now available for the first time with a Forgotten Books Full Membership.

Unlimited Access  
\$8.99/month

**Continue**

\*Fair usage policy applies



On imagining the axis on which the heart is fixed animated with a continuous circular movement and the extremity of the lever constantly pressed against the exterior border of the curve, the problem becomes, to find the form capable of changing, uniformly, a continuous circular movement into a reciprocating circular movement.

**369.** Let us first examine the simpler case of the transformation of a continuous circular movement into reciprocating rectilinear movement, by means of a heart-shaped eccentric.

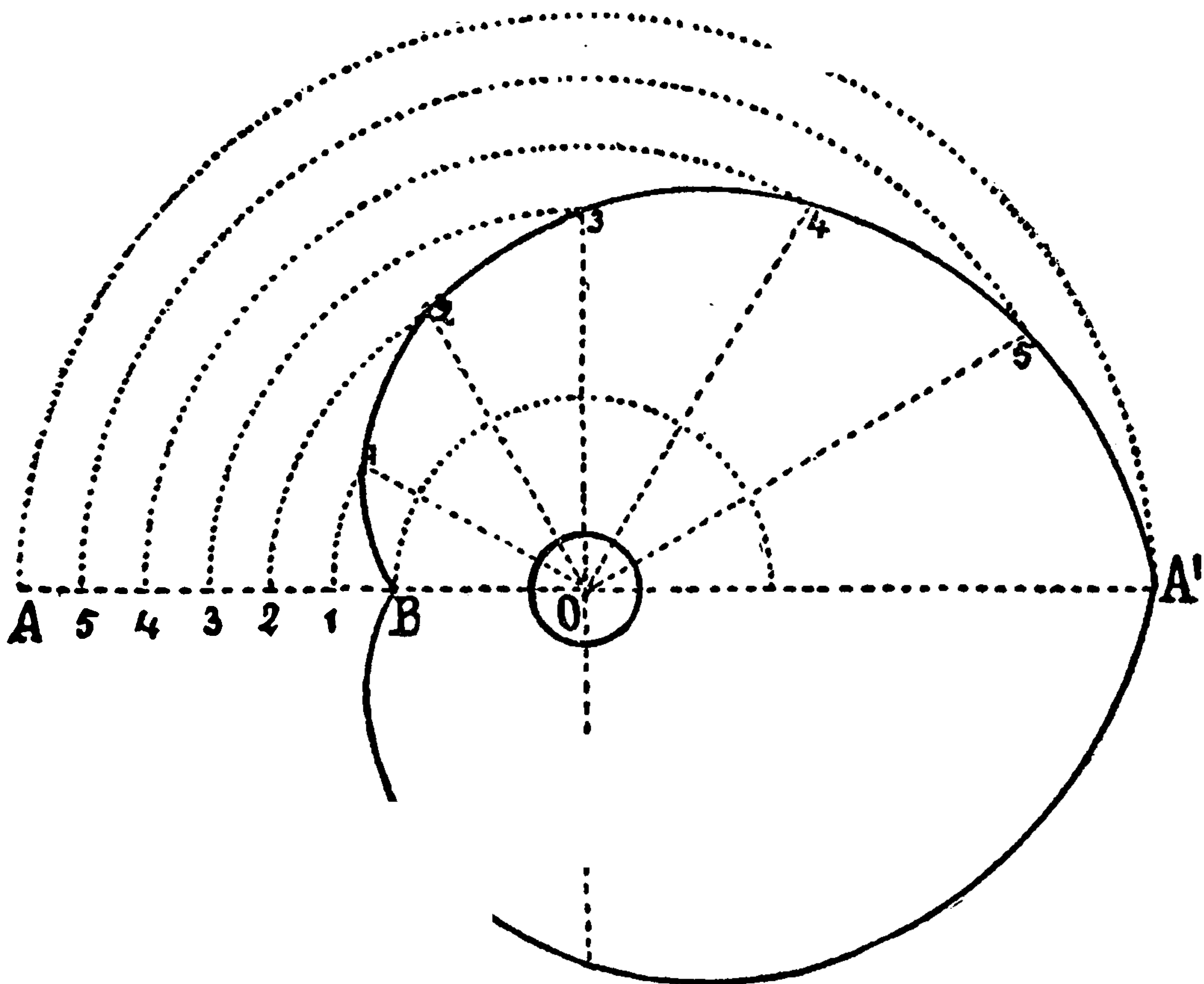

Fig. 104

Since the reciprocating movement should be uniform, the point  $B$  of the line  $AB$  (Fig. 104) should successively occupy the equidistant positions  $B, 1, 2, 3, 4, \dots, A$ , the lengths  $B1, 12, 23, 34, \dots$  being supposed equal fractional parts of the total course  $BA$ . If, from the point  $O$  as center, one described circumferences passing through the points  $B, 1, 2, 3, 4, \dots, A$ , and if one divides the circumference whose radius is  $OA$  into the same number of divisions into which the line  $AB$  has been divided, the intersections of the circumferences, with the radii passing through the points of division, will indicate successively the points through which should be described the envelope curve of the point  $B$ . By construction, the uniform movement



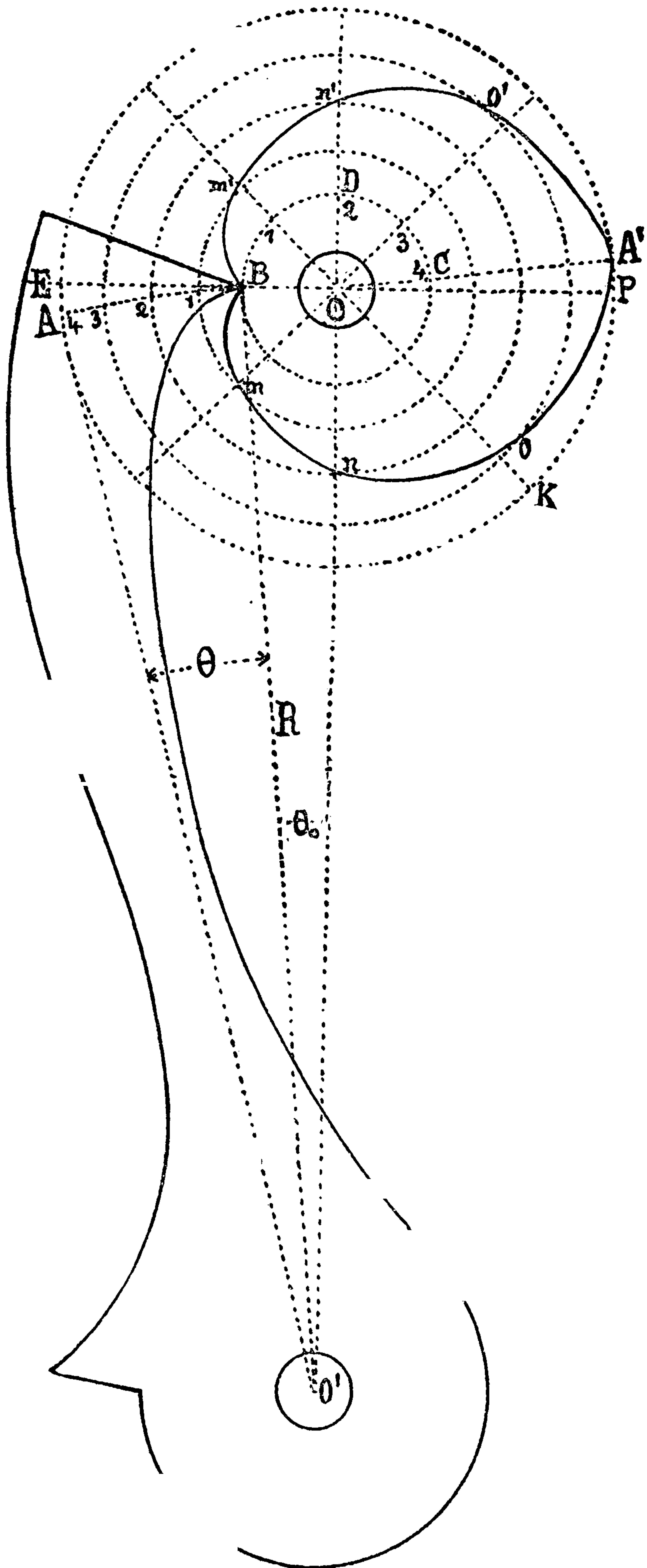

Fig. 105



of this curve around the center  $O$  will communicate a uniform rectilinear movement to the point  $B$ , alternately from  $A$  to  $B$  and from  $B$  to  $A$ , the lower part of the curve naturally being symmetrical with the upper part. One recognizes thus that the form obtained is that of a *spiral of Archimedes*, elongated, whose equation is

$$\delta = a w + C;$$

the radius vector  $\delta$  less a constant quantity,  $C$ , is always proportional to the angle described,  $w$ .

**370.** In chronographs, the reciprocating movement of the point  $B$  is not rectilinear; it is circular and its movement is executed around a center  $O'$  (Fig. 105).

Let us, therefore, now determine the shape of the heart suitable for the above new condition, and let us make the pointed end of a lever  $O' B$  traverse an arc  $A B$  with a uniform movement, while the axis  $O$  turns the arc  $B D C = \pi r_0$ . Let us divide the arcs  $A B$  and  $B D C$  into the same number of equal parts, and let us describe from the center  $O$  concentric circumferences passing through the division points of the arc  $A B$ ; draw afterward the radii passing through the division points of the arc  $B D C$ .

In order to determine, now, the points  $m, n, o, A'$  and  $m', n', o'$ , of the curve of the heart, let us consider, as in the preceding case, the intersections of the circumferences and of the radii, but let us lay off here in addition the lengths of the arcs included on each circumference between the initial radius  $B E$  and the arc described by the point  $B$  of the lever, before the points of intersection considered. One would thus obtain the curve  $B m n o A' o' n' m'$ , which would fulfill the conditions desired. In fact, supposing, for example, the point  $o$  of the heart arrived at the point  $3$  of the arc  $B A$ , the radius  $O K$  will be superposed on the radius  $B E$ , the axis of the heart has completed three-quarters of its course and in the same time the point  $B$  of the lever will have been lifted up three-quarters of the distance  $B A$ .

**371.** Let us decide to determine by calculation the value of the radius vector of the heart corresponding to the point of the lever for any position whatever of the axis of the eccentric (Fig. 106).





**THIS PAGE IS LOCKED TO FREE MEMBERS**

Purchase full membership to immediately unlock this page

# DELVE INTO FANTASY, MAGIC, MYTHOLOGY & FOLKLORE

Forgotten Books'  
Full Membership gives  
access to 797,885 ancient  
and modern, fiction and  
non-fiction books.

**Continue**

\*Fair usage policy applies



Suppose :

- $R$ , the distance between the center of rotation of the heart and that of the arm ( $R$  should also be the distance from the point of contact to the center of the arm) ;
- $r$ , the variable radius vector from the center of the heart to any point whatever of the exterior curve ;
- $r_0$ , the radius vector of the heart corresponding to the position of repose, when the hand of the chronograph is at zero ;
- $r'$ , the greatest radius vector of the heart ;
- $\alpha$ , the angle formed by the radii vector  $r_0$  and  $r$  ;
- $\theta$ , the angle formed by the line of centers  $O O'$  and the radius  $R$  of the arm when the latter is in contact with the radius vector  $r$  of the heart ;
- $\theta_0$ , this angle when the arm is in contact with the radius  $r_0$  ;
- $\theta'$ , this angle when the arm is in contact with the radius  $r'$ .

The radius  $r$  is, therefore, the chord of an arc of a circle with radius  $R$  and corresponding to angle  $\theta$  ; one can write

$$r = 2 R. \sin \frac{1}{2} \theta.$$

The angle  $\alpha$ , formed by the radius vector  $r_0$  and the radius considered  $r$ , is different from the angle which the heart should turn starting from the position of repose to the instant when the radius  $r$  coincides with the point of the lever. Designating this last angle by  $\gamma$ , we have in effect

$$\gamma = \alpha \pm \beta,$$

according as the axis turns to the left or to the right,  $\beta$  being the angle formed by the fixed direction of the radius  $r_0$  and that which the radius  $r$  takes at the moment of contact with the lever. Let us place

$$\beta = \frac{1}{2} (\theta - \theta_0),$$

this angle being inscribed in the circumference with radius  $R$  and  $\theta - \theta_0$  angle at the center embracing the same arc. We will have, consequently,

$$\gamma = \alpha \pm (\theta - \theta_0).$$

Let us now establish the relation which connects the angles  $\theta - \theta_0$  and  $\gamma$ , angles which should be in a determined relation, by virtue of the mechanical principle stating that the transmission of the force is uniform when the angles traversed in the same time by two mobiles which drive each other remain constantly in the same relation. But when the lever traverses the total angle  $\theta' - \theta_0$ ,



the heart executes a demi-turn, therefore, an angle equal to  $\pi$ ; one will, therefore, have

$$\frac{\gamma}{\theta - \theta_0} = \frac{\pi}{\theta' - \theta_0},$$

from whence

$$\gamma = \frac{\pi (\theta - \theta_0)}{\theta' - \theta_0}.$$

Consequently, one can write

$$\text{and } \alpha = \pi \frac{\theta - \theta_0}{\theta' - \theta_0} \mp \frac{1}{2} (\theta - \theta_0)$$

$$\text{and also } \alpha = \pi \frac{\theta}{\theta' - \theta_0} - \pi \frac{\theta_0}{\theta' - \theta_0} \mp \frac{1}{2} \theta \pm \frac{1}{2} \theta_0$$

$$\alpha + \pi \frac{\theta_0}{\theta' - \theta_0} \mp \frac{1}{2} \theta_0 = \pi \frac{\theta}{\theta' - \theta_0} \mp \frac{1}{2} \theta,$$

from whence

$$\alpha + \pi \frac{\theta_0}{\theta' - \theta_0} \mp \frac{1}{2} \theta_0 = \left( \frac{\pi}{\theta' - \theta_0} \mp \frac{1}{2} \right) \theta.$$

One will thus have

$$\theta = \frac{\alpha + \pi \frac{\theta_0}{\theta' - \theta_0} \mp \frac{1}{2} \theta_0}{\frac{\pi}{\theta' - \theta_0} \mp \frac{1}{2}} = \frac{\alpha}{\frac{\pi \pm \frac{1}{2} (\theta' - \theta_0)}{\theta' - \theta_0}} + \theta_0.$$

The equation of the two branches of the curve of the heart expressed in polar co-ordinates will, therefore, be

$$r = 2 R \sin \frac{1}{2} \left( \frac{\alpha}{\frac{\pi}{\theta' - \theta_0} \pm \frac{1}{2}} + \theta_0 \right)$$

**372. NUMERICAL CALCULATION.**—Let us admit

$$r_0 = 2 R \sin \frac{1}{2} \theta_0 = 4. \quad r_1 = 2 R \sin \frac{1}{2} \theta' = 24. \quad R = 140.$$

We will have which gives  $\sin \frac{1}{2} \theta_0 = \frac{4}{280}$  and  $\sin \frac{1}{2} \theta' = \frac{24}{280}$ ,

consequently,  $\theta_0 = 1^\circ 38' 13.6''$   
 $\theta' = 9^\circ 50' 3''$ ;

$$\theta' - \theta_0 = 8^\circ 11' 49.4''.$$

Expressed in seconds of the arc, the angles  $\theta_0$ ,  $\theta' - \theta_0$  and  $\pi$  give

$$\begin{aligned} \theta_0 &= 5893.6 \text{ seconds} \\ \theta' - \theta_0 &= 29509.4 \dots \text{ " } \\ \pi &= 684000 \dots \text{ " } \end{aligned}$$

Let us first calculate this equation under the form

$$r = 2 R \sin \frac{1}{2} \left( \frac{\alpha}{\frac{\pi + \frac{1}{2} (\theta' - \theta_0)}{\theta' - \theta_0}} + \theta_0 \right)$$

and suppose  $\alpha = 30^\circ$ .



We will have

$$\begin{array}{rcl} \pi = 648000'' & \log : (\pi + \frac{1}{2} (\theta' - \theta_0)) & = 5.8213528 \\ \frac{1}{2} (\theta' - \theta_0) = \frac{14754.7}{662754.7} & - \log : (\theta' - \theta) & = \frac{4.4699589}{1.3513939} \end{array}$$

$$\text{The angle } \alpha = 30^\circ = 108000''$$

$$\log : 108000 = 5.0334238$$

$$- \log : \frac{\pi + \frac{1}{2} (\theta' - \theta_0)}{\theta' - \theta} = \frac{1.3513939}{3.6820299} \log : 4808.72''.$$

$$4808.72 + \theta_0 = 4808.72 + 5893.6 = 10702.32'' ;$$

therefore,

$$\begin{array}{l} \theta = 2^\circ 58' 22.32'' \\ \frac{1}{2} \theta = 1^\circ 29' 11.16'' \end{array}$$

$$\log \cdot \sin \frac{1}{2} \theta = 8.4139741$$

$$\log : 2 R = \frac{2.4471580}{0.8611321}$$

$$\log : 2 R \sin \frac{1}{2} \theta = 0.8611321$$

from whence

$$r = 7.26327 \text{ for } \alpha = 30^\circ.$$

Similar calculations will give successively

$$\begin{array}{ll} r = 10.5254 & \text{for } \alpha = 60^\circ \\ r = 13.7862 & \text{“ } \alpha = 90^\circ \\ r = 17.0451 & \text{“ } \alpha = 120^\circ \\ r = 20.3017 & \text{“ } \alpha = 150^\circ \\ r = 23.5623 & \text{“ } \alpha = 180^\circ \end{array}$$

For the other branch of the curve the formula would be

$$r = 2 R \sin \frac{1}{2} \left( \frac{\alpha}{\frac{\pi - \frac{1}{2} (\theta' - \theta_0)}{\theta' - \theta_0}} + \theta_0 \right),$$

and identical calculations to the preceding would give the following results :

$$\begin{array}{ll} r = 7.4153 & \text{for } \alpha = 30^\circ \\ r = 10.8294 & \text{“ } \alpha = 60^\circ \\ r = 14.240 & \text{“ } \alpha = 90^\circ \\ r = 17.66 & \text{“ } \alpha = 120^\circ \\ r = 21.06 & \text{“ } \alpha = 150^\circ \\ r = 24.4648 & \text{“ } \alpha = 180^\circ \end{array}$$

For this last calculation, the radius  $r$  no longer belongs to the closed curve, but rather to the prolongation of this curve. Let us remark that the greatest radius vector should be equal to 24.





**THIS PAGE IS LOCKED TO FREE MEMBERS**

Purchase full membership to immediately unlock this page



# HISTORY

Tens of thousands of important historical sources, many previously unobtainable, are now available for the first time with a Forgotten Books Full Membership.

Unlimited Access  
\$8.99/month

**Continue**

\*Fair usage policy applies







# THE WATCH ADJUSTER'S MANUAL

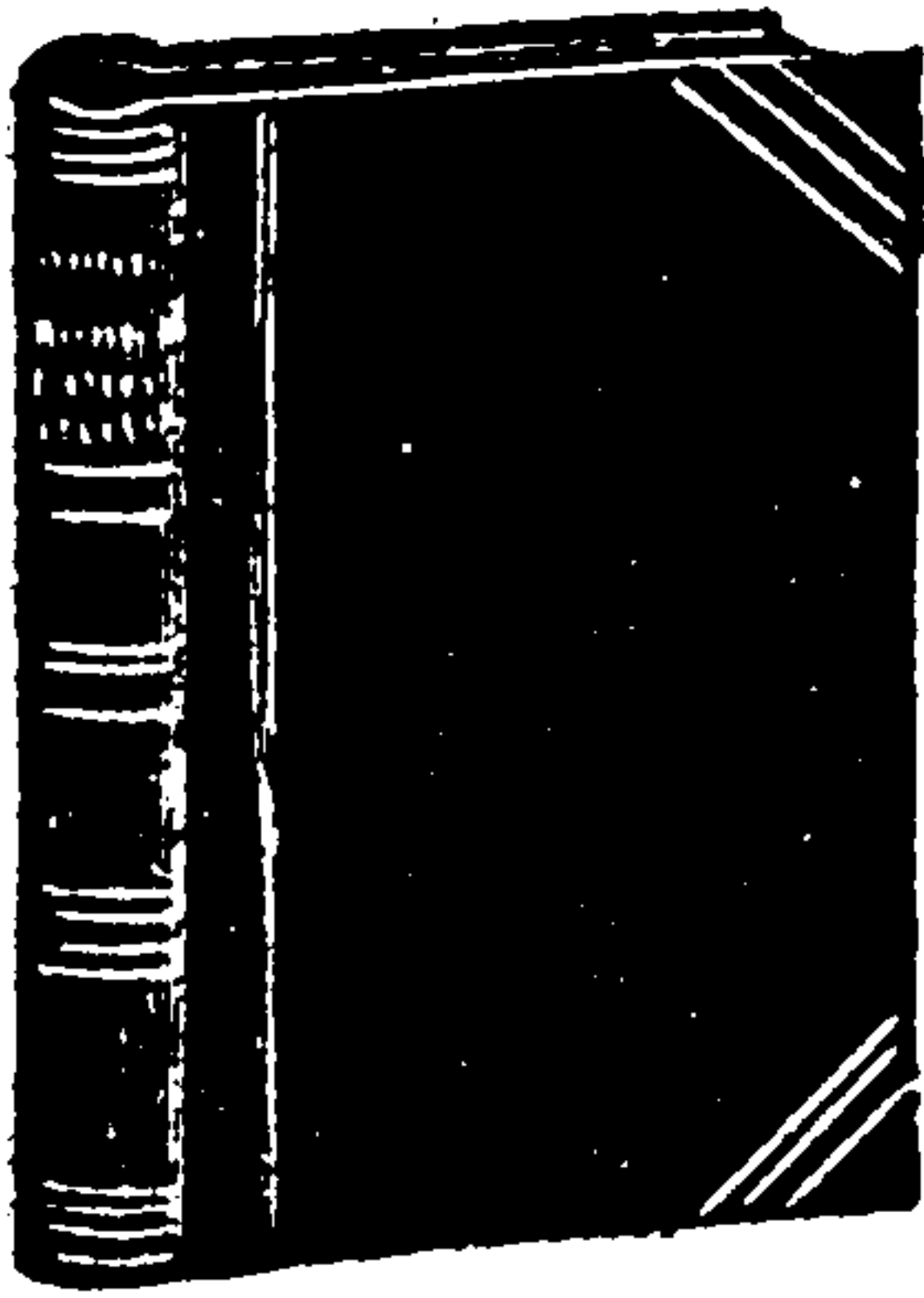

A Complete and Practical Guide for  
Watchmakers in Adjusting Watches  
and Chronometers for Isochronism,  
Position, Heat and Cold.

---

BY CHARLES EDGAR FRITTS (EXCELSIOR),

Author of "Practical Hints on Watch Repairing," "Practical Treatise on Balance  
Spring," "Electricity and Magnetism for Watchmakers," etc., etc.

---

This well-known work is now recognized as the standard authority on the adjustments and kindred subjects, both here and in England. It contains an exhaustive consideration of the various theories proposed, the mechanical principles on which the adjustments are based, and the different methods followed in actual practice, giving all that is publicly known in the trade, with a large amount of entirely new practical matter not to be found elsewhere, obtained from the best manufacturers and workmen, as well as from the author's own studies and experiences.

**Sent postpaid to any part of the world on receipt of**

**\$2.50 (10s. 5d.)**

---

Published by THE KEYSTONE

THE ORGAN OF THE JEWELRY AND OPTICAL TRADES  
19TH & BROWN STS., PHILADELPHIA, U. S. A.



# Watch and Clock Escapements

---

A masterly treatise on the lever, cylinder and chronometer escapements, with an illustrated history of the evolution and development of the escapement idea in horology.

---

This book is noted for its practical character and for the number and excellence of the illustrations. It is the work of two of the most accomplished and experienced teachers of horology in the United States, and their skill in imparting their knowledge to students is shown on every page of the book both in text and in illustration.

Though thoroughly scientific, it is lucid in statement and surprisingly easy of comprehension, even to students of limited mathematical or geometrical attainments. Any watchmaker, student of horology or apprentice can easily master it without the aid of an instructor or attendance at a school.

It is conceded to be the most complete and lucid work on the three principal escapements available to students of horology.

An interesting appendix to the book is an illustrated history of escapements from the first crude conceptions to their present perfection ; also an illustrated article telling lucidly and step by step how to put in a new cylinder—a most practical bit of information for the watch repairer.

**Bound in silk cloth ; 198 pages and 216 illustrations.**

**Sent postpaid to any part of the world on receipt of price  
\$1.50 (6s. 3d.)**

---

Published by **THE KEYSTONE,**  
THE ORGAN OF THE JEWELRY AND OPTICAL TRADES,  
19TH AND BROWN STS., PHILADELPHIA, U.S.A.





**THIS PAGE IS LOCKED TO FREE MEMBERS**

Purchase full membership to immediately unlock this page

# DELVE INTO FANTASY, MAGIC, MYTHOLOGY & FOLKLORE

Forgotten Books'  
Full Membership gives  
access to 797,885 ancient  
and modern, fiction and  
non-fiction books.

**Continue**

\*Fair usage policy applies



# THE KEYSTONE RECORD BOOK OF WATCH REPAIRS

---

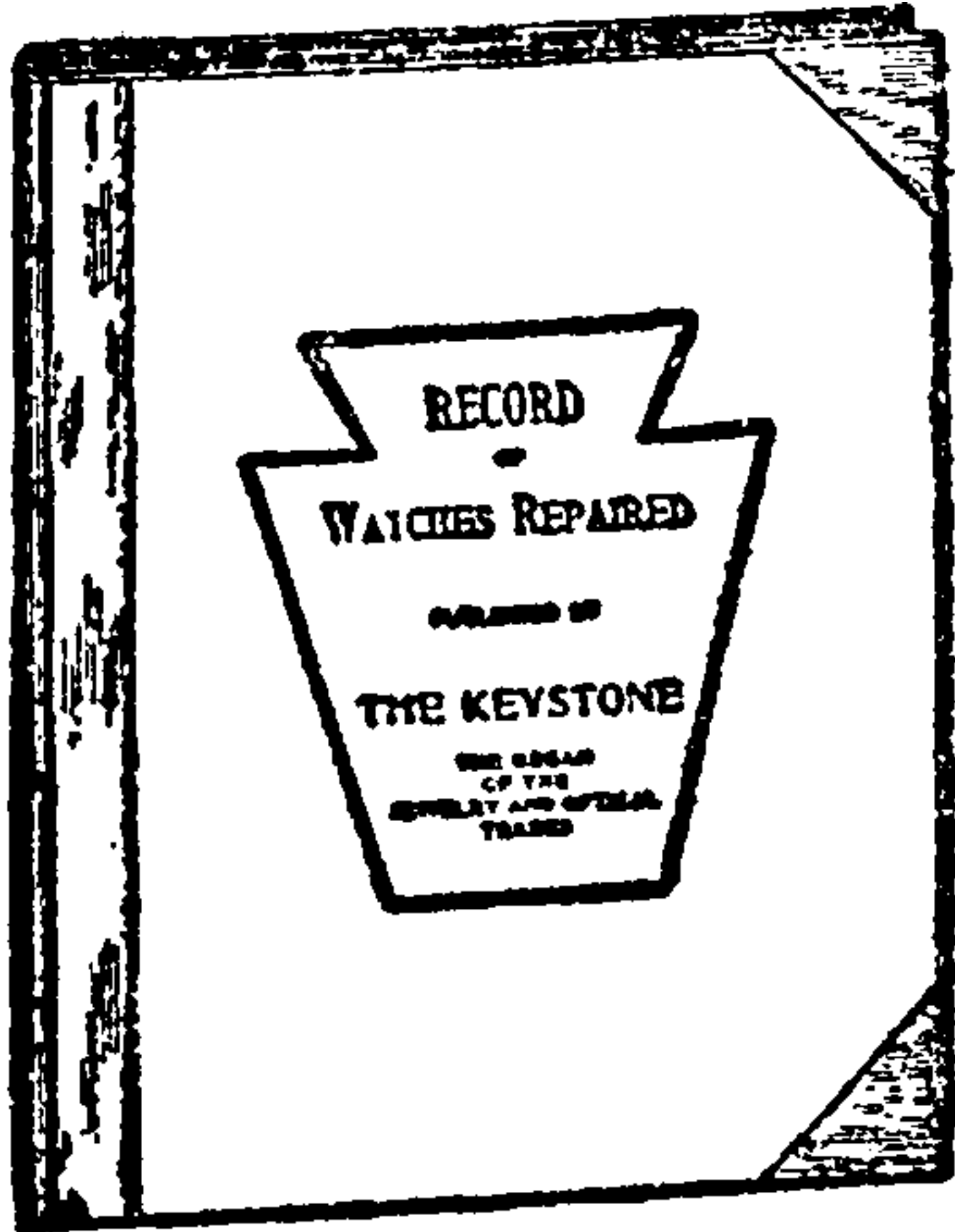

Method in repair work makes it essential for every jeweler to keep a specially prepared book for recording watch repairs.

The ideal book of this character is the Keystone Record Book of Watch Repairs, which has space for sixteen hundred entries.

Only a scratch of the pen under printed headings and you have a permanent record of watches repaired, charges, etc.

This book is necessary for reference, systematizes bench business, and saves labor and time in bookkeeping.

It is made of fine, durable paper, has 120 pages measuring 9 x 11 inches, and is substantially bound in cloth, with leather back and corners.

It is much better and one-third lower priced than any other book of its kind on the market. About three-fourths of the jewelry trade now use it.

Bound in Cloth, with Leather Back and Corners

Sent postpaid to any part of the world on receipt of price,  
**\$1.00 (4s. 2d.)**

---

Published by **THE KEYSTONE**  
THE ORGAN OF THE JEWELRY AND OPTICAL TRADES  
19TH & BROWN STS., PHILADELPHIA, U.S.A.



# THE KEYSTONE BOOK OF GUARANTEES OF WATCH REPAIRS

---



The success of the watch repairer is proportional to the confidence of the public in his work.

The best workmanship fails from a business standpoint if the workman does not convince his customers that it is the best.

The one effective way to do this is to give a signed guarantee with it, and the cheapest, safest and best form of guarantee for this purpose is found in The Keystone Book of Repair Guarantees.

This book contains 200 printed guarantees, and is handsomely bound. Each guarantee is  $3\frac{1}{4}$  x  $7\frac{1}{2}$  inches, and most carefully worded.

Jewelers have discovered that the use of these guarantees is a most effective way to secure and cultivate public confidence.

Bound in Cloth, with Leather Back and Corners

Sent postpaid to any part of the world on receipt of price,  
**\$1.00** (4s. 2d.)

---

Published by **THE KEYSTONE**  
THE ORGAN OF THE JEWELRY AND OPTICAL TRADES  
19TH & BROWN STS., PHILADELPHIA, U.S.A.



# THE KEYSTONE BOOK OF MONOGRAMS

---

This book contains **2400 designs** and **over 6000 different combinations of two and three letters.**

Is an essential to every jeweler's outfit. It is not only necessary for the jeweler's own use and guidance, but also to enable customers to indicate exactly what they want, thus saving time and possible dissatisfaction.

The Monograms are purposely left in outline, in order to show clearly how the letters are intertwined or woven together. This permits such enlargement or reduction of the Monogram as may be desired, and as much shading, ornamentation and artistic finish as the jeweler may wish to add.

This comprehensive compilation of Monograms is especially available as a reference book in busy seasons. Its use saves time, thought and labor, and ensures quick and satisfactory work.

Monograms are the fad of the time, and there's money for the jeweler in Monogram engraving. The knowledge in this book can be turned into cash. All the various styles of letters are illustrated.

**Price, \$1.00 (4s. 2d.)**

---

Published by **THE KEYSTONE,**  
**THE ORGAN OF THE JEWELRY AND OPTICAL TRADES,**  
**19TH & BROWN STS., PHILADELPHIA, U. S. A.**





**THIS PAGE IS LOCKED TO FREE MEMBERS**

Purchase full membership to immediately unlock this page



# HISTORY

Tens of thousands of important historical sources, many previously unobtainable, are now available for the first time with a Forgotten Books Full Membership.

Unlimited Access  
\$8.99/month

**Continue**

\*Fair usage policy applies



# THE OPTICIAN'S MANUAL

## VOL. I.

BY C. H. BROWN, M. D.

Graduate University of Pennsylvania; Professor of Optics and Refraction; formerly Physician in Philadelphia Hospital; Member of Philadelphia County, Pennsylvania State and American Medical Societies.

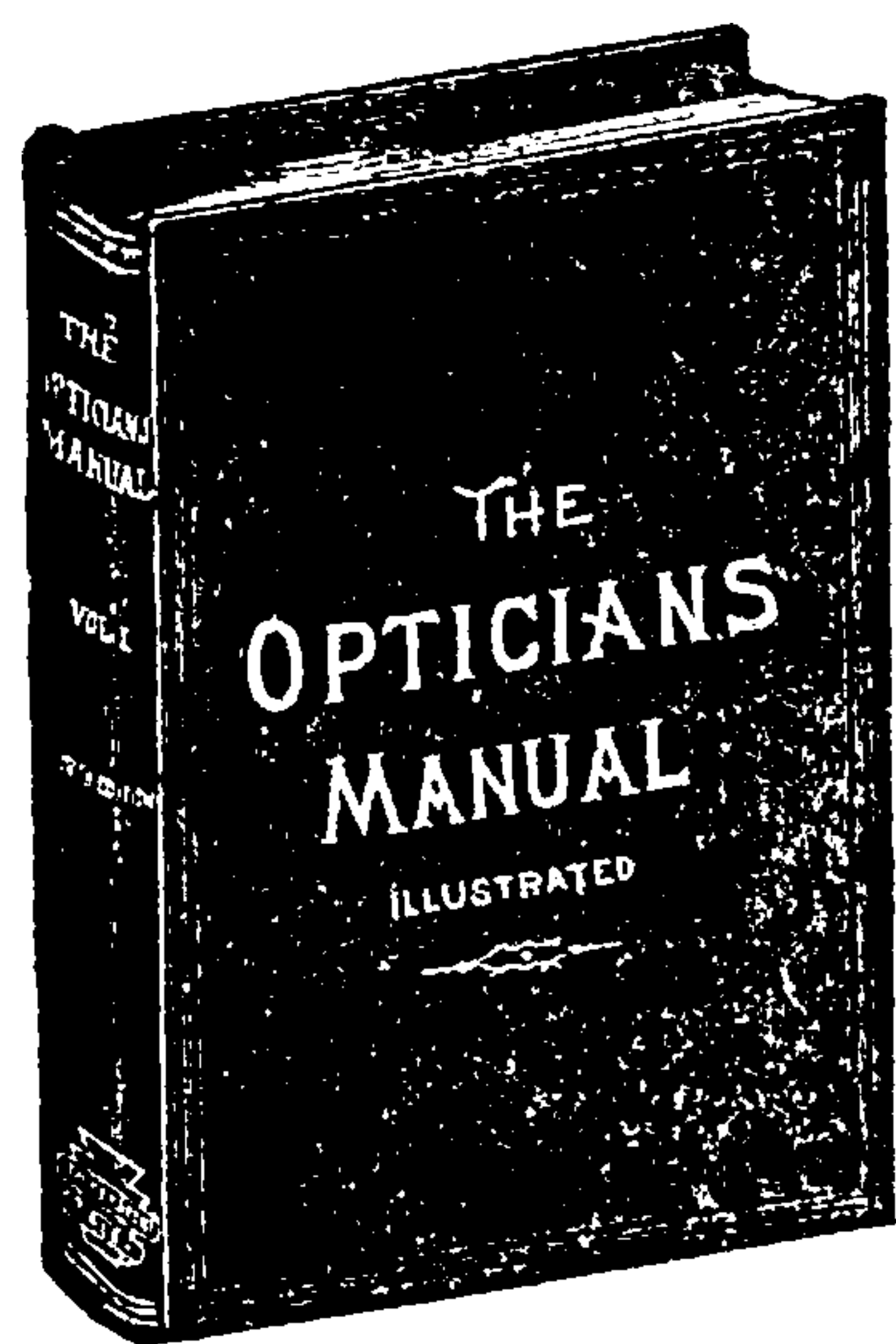

The Optician's Manual, Vol. I., has proved to be the most popular work on practical refraction ever published. The knowledge it contains has been more effective in building up the optical profession than any other educational factor. A study of it is essential to an intelligent appreciation of Vol. II., for it lays the foundation structure of all optical knowledge, as the titles of its ten chapters show :

- Chapter I.—Introductory Remarks.
- Chapter II.—The Eye Anatomically.
- Chapter III.—The Eye Optically; or, The Physiology of Vision.
- Chapter IV.—Optics.
- Chapter V.—Lenses.
- Chapter VI.—Numbering of Lenses.
- Chapter VII.—The Use and Value of Glasses.
- Chapter VIII.—Outfit Required.
- Chapter IX.—Method of Examination.
- Chapter X.—Presbyopia.

The Optician's Manual, Vol. I., is complete in itself, and has been the entire optical education of many successful opticians. For student and teacher it is the best treatise of its kind, being simple in style, accurate in statement and comprehensive in its treatment of refractive procedure and problems. It merits the place of honor beside Vol. II. in every optical library.

Bound in Cloth—422 pages—colored plates and illustrations.

Sent postpaid on receipt of **\$1.50** (6s. 3d.)

---

Published by THE KEYSTONE,  
THE ORGAN OF THE JEWELRY AND OPTICAL TRADES,  
19TH & BROWN STS., PHILADELPHIA, U. S. A.



# THE OPTICIAN'S MANUAL

## VOL. II.

BY C. H. BROWN, M. D.

Graduate University of Pennsylvania; Professor of Optics and Refraction; formerly Physician in Philadelphia Hospital; Member of Philadelphia County, Pennsylvania State and American Medical Societies.

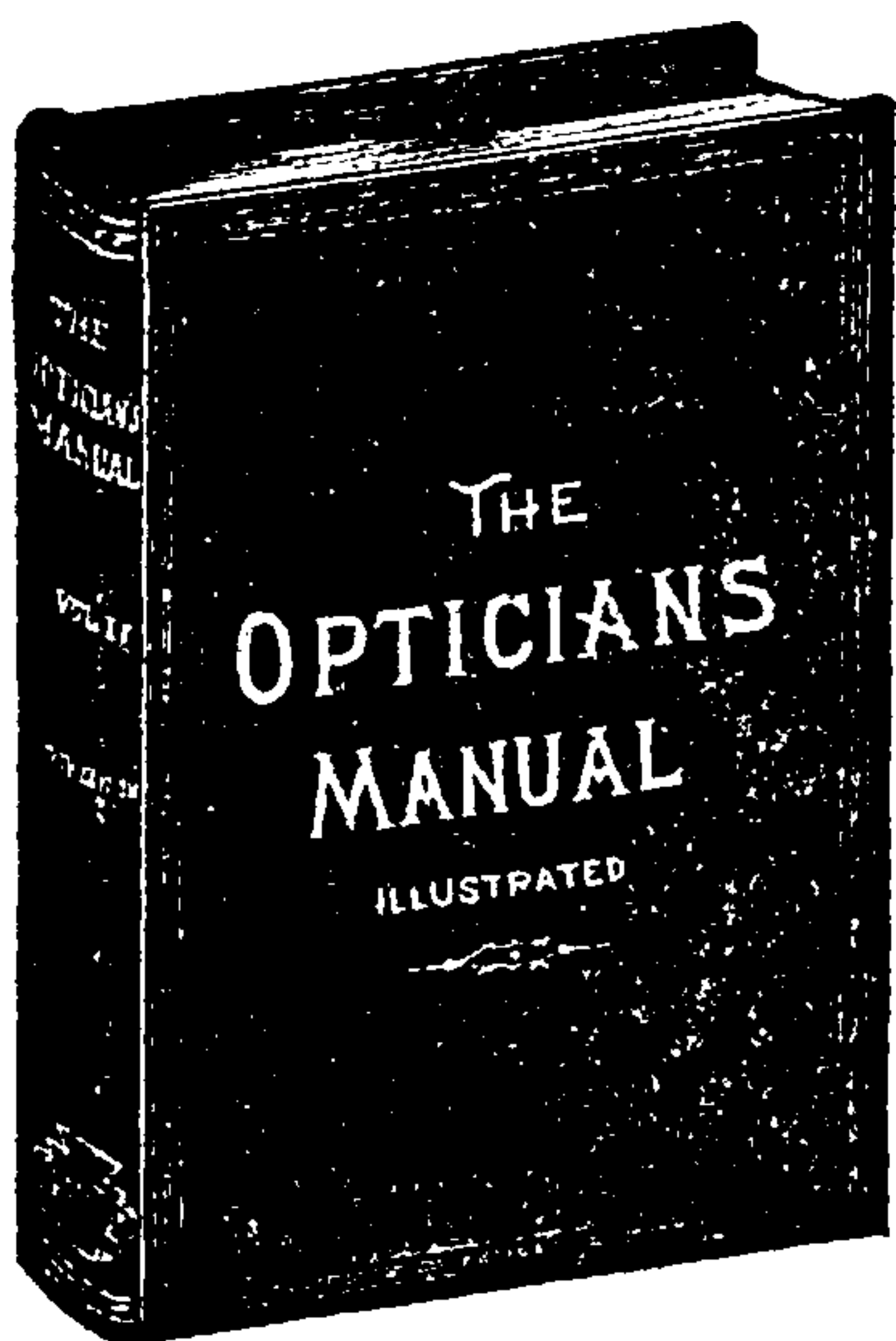

The Optician's Manual, Vol. II., is a direct continuation of The Optician's Manual, Vol. I., being a much more advanced and comprehensive treatise. It covers in minutest detail the four great subdivisions of practical eye refraction, viz :

**Myopia.**

**Hypermetropia.**

**Astigmatism.**

**Muscular Anomalies.**

It contains the most authoritative and complete researches up to date on these subjects, treated by the master hand of an eminent oculist and optical teacher. It is thoroughly practical, explicit in statement and accurate as to fact. All refractive errors and complications are clearly explained, and the methods of correction thoroughly elucidated.

This book fills the last great want in higher refractive optics, and the knowledge contained in it marks the standard of professionalism.

Bound in Cloth—408 pages—with illustrations.

Sent postpaid on receipt of **\$1.50** (6s. 3d.)

---

Published by THE KEYSTONE,  
THE ORGAN OF THE JEWELRY AND OPTICAL TRADES,  
19TH & BROWN STS., PHILADELPHIA, U. S. A.



# PHYSIOLOGIC OPTICS

## Ocular Dioptrics—Functions of the Retina—Ocular Movements and Binocular Vision

BY DR. M. TSCHERNING

Director of the Laboratory of Ophthalmology at the Sorbonne, Paris

---

### AUTHORIZED TRANSLATION

BY CARL WEILAND, M.D.

Former Chief of Clinic in the Eye Department of the Jefferson College Hospital, Philadelphia, Pa.

---

This translation, now in its second edition, is the most masterful treatise on physiologic optics. Its distinguished author is recognized in the world of science as the greatest living authority on this subject, and his book embodies not only his own researches, but those of several hundred investigators, who, in the past hundred years, made the eye their specialty and life study.

Tscherning has sifted the gold of all optical research from the dross, and his book, as revised and enlarged by himself for the purposes of this translation, is the most valuable mine of reliable optical knowledge within the reach of ophthalmologists. It contains 380 pages and 212 illustrations, and its reference list comprises the entire galaxy of scientists who devoted their researches to this subject.

The chapters on Ophthalmometry, Ophthalmoscopy, Accommodation, Astigmatism, Aberration and Entopic Phenomena, etc.—in fact, the entire book contains so much that is new, practical and necessary that no refractionist can afford to be without it.

Bound in Cloth. 380 Pages, 212 Illustrations

Price, **\$2.50** (10s. 5d.)

---

Published by **THE KEYSTONE**

THE ORGAN OF THE JEWELRY AND OPTICAL TRADES  
19TH & BROWN STS., PHILADELPHIA, U.S.A.





**THIS PAGE IS LOCKED TO FREE MEMBERS**

Purchase full membership to immediately unlock this page

# DELVE INTO FANTASY, MAGIC, MYTHOLOGY & FOLKLORE

Forgotten Books'  
Full Membership gives  
access to 797,885 ancient  
and modern, fiction and  
non-fiction books.

**Continue**

\*Fair usage policy applies



# SKIASCOPIY

## AND THE USE OF THE RETINOSCOPE

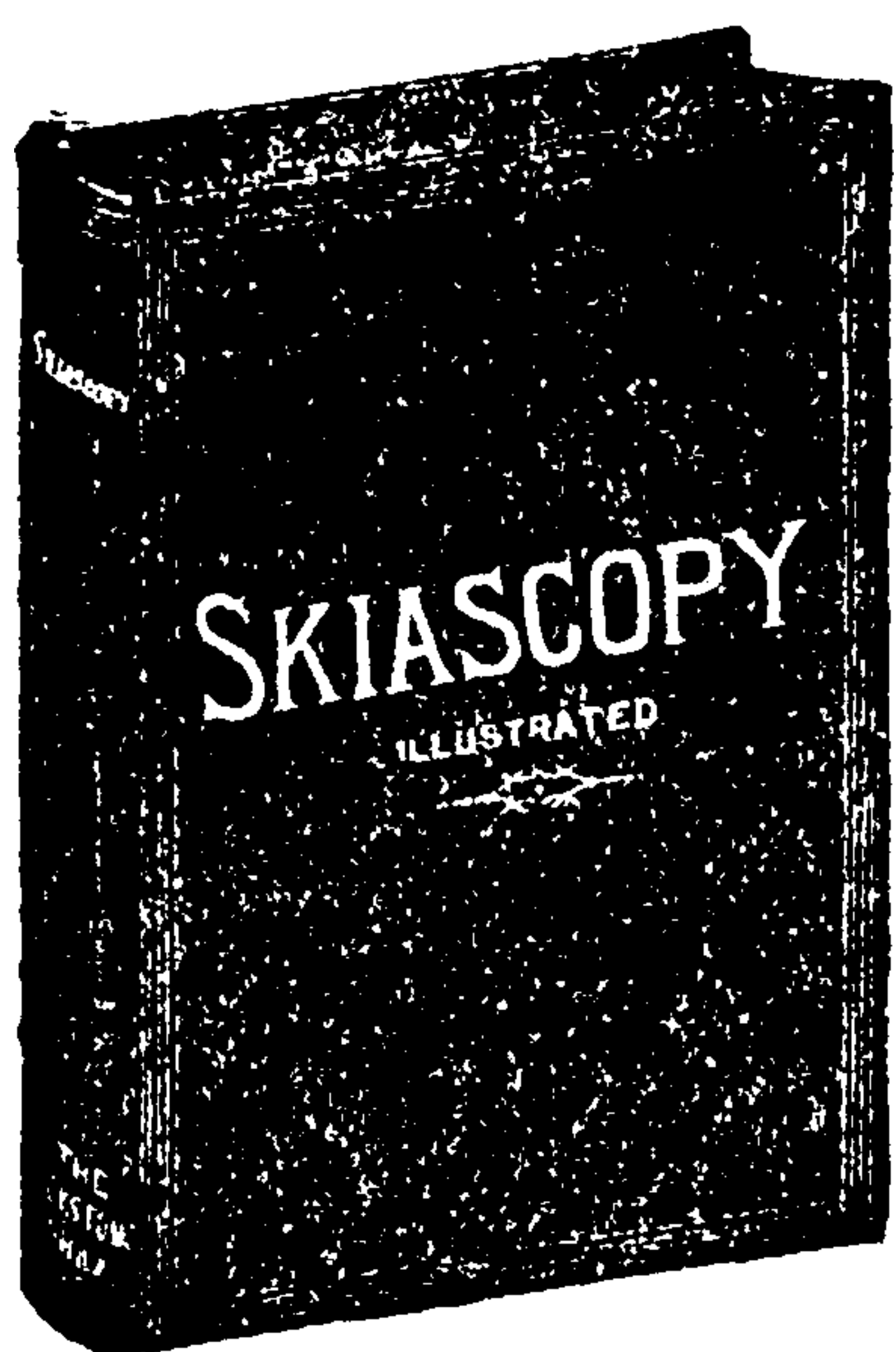

A Treatise on the Shadow Test in its Practical Application to the Work of Refraction, with an Explanation in Detail of the Optical Principles on which the Science is Based.

This new work, the sale of which has already necessitated a second edition, far excels all previous treatises on the subject in comprehensiveness and practical value to the refractionist. It not only explains the test, but expounds fully and explicitly the principles underlying it—not only the phenomena revealed by the test, but the why and wherefore of such phenomena.

It contains a full description of skiascopic apparatus, including the latest and most approved instruments.

In depth of research, wealth of illustration and scientific completeness this work is unique.

**Bound in cloth; contains 231 pages and 73 illustrations and colored plates.**

Sent postpaid to any part of the world on receipt of **\$1.00 (4s. 2d.)**

---

Published by **THE KEYSTONE,**  
THE ORGAN OF THE JEWELRY AND OPTICAL TRADES,  
19TH AND BROWN STS., PHILADELPHIA, U.S.A.



# OPHTHALMIC LENSES

## Dioptric Formulæ for Combined Cylindrical Lenses, The Prism-Dioptry and Other Original Papers

BY CHARLES F. PRENTICE, M. E.

A new and revised edition of all the original papers of this noted author, combined in one volume. In this revised form, with the addition of recent research, these standard papers are of increased value. Combined for the first time in one volume, they are the greatest compilation on the subject of lenses extant.

This book of over 200 pages contains the following papers :

**Ophthalmic Lenses.**

**Dioptric Formulæ for Combined Cylindrical Lenses.**

**The Prism-Dioptry.**

**A Metric System of Numbering and Measuring Prisms.**

The Relation of the Prism-Dioptry to the Meter Angle.

The Relation of the Prism-Dioptry to the Lens-Dioptry.

**The Perfected Prismometer.**

**The Prismometric Scale.**

**On the Practical Execution of Ophthalmic Prescriptions involving Prisms.**

**A Problem in Cemented Bifocal Lenses, Solved by the Prism-Dioptry.**

**Why Strong Contra-Generic Lenses of Equal Power Fail to Neutralize Each Other.**

**The Advantages of the Sphero-Toric Lens.**

**The Iris, as Diaphragm and Photostat.**

**The Typoscope.**

**The Correction of Depleted Dynamic Refraction (Presbyopia).**

### *Press Notices on the Original Edition :*

#### OPHTHALMIC LENSES.

"The work stands alone, in its present form, a compendium of the various laws of physics relative to this subject that are so difficult of access in scattered treatises."—*New England Medical Gazette.*

"It is the most complete and best illustrated book on this special subject ever published."—*Horological Review*, New York.

"Of all the simple treatises on the properties of lenses that we have seen, this is incomparably the best. . . . The teacher of the average medical student will hail this little work as a great boon"—*Archives of Ophthalmology*, edited by H. Knapp, M.D.

#### DIOPTRIC FORMULÆ FOR COMBINED CYLINDRICAL LENSES.

"This little brochure solves the problem of combined cylinders in all its aspects, and in a manner simple enough for the comprehension of the average student of ophthalmology. The author is to be congratulated upon the success that has crowned his labors, for nowhere is there to be found so simple and yet so complete an explanation as is contained in these pages."—*Archives of Ophthalmology*, edited by H. Knapp, M.D.

"This exhaustive work of Mr. Prentice is a solution of one of the most difficult problems in ophthalmological optics. Thanks are due to Mr. Prentice for the excellent manner in which he has elucidated a subject which has not hitherto been satisfactorily explained."—*The Ophthalmic Review*, London.

**The book contains 110 Original Diagrams. Bound in cloth.**

**Price, \$1.50 (6s. 3d.)**

Published by **THE KEYSTONE**,  
THE ORGAN OF THE JEWELRY AND OPTICAL TRADES,  
19TH & BROWN STS., PHILADELPHIA, U. S. A.



# TESTS AND STUDIES OF THE OCULAR MUSCLES

BY ERNEST E. MADDOX, M. D., F. R. C. S., ED.

Ophthalmic surgeon to the Royal Victoria Hospital, Bournemouth; formerly assistant  
ophthalmic surgeon to the Royal Infirmary, Edinburgh

---

SECOND EDITION

Revised and enlarged by the author

---

The sub-division of refractive work that most troubles the optician is muscular anomalies. Even those who have mastered all the other intricacies of visual correction will often find their skill frustrated and their efforts nullified if they have not thoroughly mastered the ocular muscles—their functions and failings. The optician can thoroughly equip himself in this fundamental essential by studying the excellent treatise “The Ocular Muscles,” by Dr. Maddox, who is recognized in the medical world as one of the leading authorities on the subject of eye muscles.

This work is the most complete and masterful ever compiled on this important branch of ophthalmology, covering thoroughly the symptoms, tests and treatment of muscular anomalies. The accomplished author has devoted a lifetime of study and research to his subject, and the book throughout is marked by an explicitness and simplicity of language that make its study a pleasure to the eye specialist.

Bound in Cloth. Over 100 Well Executed Illustrations

Sent postpaid to any part of the world on receipt of **\$1.50** (6s. 3d.)

---

Published by THE KEYSTONE

THE ORGAN OF THE JEWELRY AND OPTICAL TRADES

19TH & BROWN STS., PHILADELPHIA, U. S. A.





**THIS PAGE IS LOCKED TO FREE MEMBERS**

Purchase full membership to immediately unlock this page



# HISTORY

Tens of thousands of important historical sources, many previously unobtainable, are now available for the first time with a Forgotten Books Full Membership.

Unlimited Access  
\$8.99/month

**Continue**

\*Fair usage policy applies