

A TREATISE
ON THE
TEETH OF WHEELS,

DEMONSTRATING
THE BEST FORMS WHICH CAN BE GIVEN TO THEM FOR THE
PURPOSES OF MACHINERY;

SUCH AS
MILL-WORK AND CLOCK-WORK,

AND THE
ART OF FINDING THEIR NUMBERS.

TRANSLATED FROM THE FRENCH OF

M. CAMUS:

THE SECOND EDITION, CAREFULLY REVISED AND ENLARGED;

WITH

DETAILS OF THE PRESENT PRACTICE OF MILL-WRIGHTS,
ENGINE MAKERS, AND OTHER MECHANISTS,

BY

JOHN ISAAC HAWKINS,

CIVIL ENGINEER.

ILLUSTRATED BY EIGHTEEN PLATES.

LONDON:

JAMES S. HODSON, 112, FLEET STREET;
J. WEALE, ARCHITECTURAL LIBRARY, 59, HIGH HOLBORN;
G. HEBERT, MECHANICAL AND SCIENTIFIC LIBRARY,
88, CHEAPSIDE.

1837.

W. A. 1

TJ 124

C 3

1857

LONDON:

PRINTED BY J. S. HODSON, CROSS STREET,
HATTON GARDEN.

PREFACE

TO THE FIRST EDITION.

IMPROVEMENT in science is frequently very slow, being retarded either by ignorance or prejudice, both of which too often prevail among those who have the best opportunity of making practical observations. Mechanics in general, conduct their operations according to a certain routine, which they have acquired by experience; and as they are little versed in theory, or the mathematical principles of what they profess, they seldom think of going beyond the beaten track in which they have been accustomed to move. Some of our greatest engineers, indeed, have been men of no education*; they attained to eminence merely by the natural force of their genius, and of course were liable to fall into mistakes, which the man versed in mathematical knowledge could either rectify or avoid. We need not therefore be surprised that the proper formation of the teeth of wheels, which is of so much importance in mechanics, should have been

* Of this we have an instance in the celebrated Brindley.

so much overlooked and neglected as they are found to be.

The perfection of the most simple as well as the most complicated engines, depends greatly upon the due action of the teeth of the wheels with each other, or, in other words, on the best form for ensuring their proper action with the least friction, and of course with the least wear and loss of power.

It is needless here to state of what vast consequence the numerous and immense machines are to the manufactures of this country, or what prodigious sums of money are involved therein. It is therefore of great importance that the best form for the teeth of wheels should be ascertained on true mathematical principles, and that they should not be left, as is too much the case, to the random guesses of workmen. If the teeth of wheels be properly constructed, the work is more equably performed, and of course is better done; less force or moving power is requisite, or, more work may be done with a given power; and, to crown all, the whole machinery has greater durability, consequently costs less for repairs, and occasions less loss of valuable time, by not being so frequently obliged to stand still. Now the saving of power, of expense, and of time in repairs, are objects by no means to be lightly thought of. Under such impressions, an intelligent and ingenious friend ad-

vised the publisher to procure a translation of that part of M. Camus's "Cours de Mathématique," which treats on the best form of the teeth of wheels, as being scientifically handled, and on true mathematical principles.

M. Camus having gone through the subject of the proper form for the teeth of wheels, goes on to describe the art of finding the number of teeth and leaves which ought to be given to wheels and pinions, and likewise the application of these principles to trains of wheel-work in general, an operation which in clock and watch-work is called calibrating, as it likewise determines the diameters of the wheels and pinions.

Of M. Camus it may not be uninteresting to say, that when only twelve years of age, his progress in science was so great, that he was able to give lectures on the mathematics at Paris; and at an early period he attained the highest academic honours of his own country and of most foreign Academies. In 1765 he was elected a Fellow of the Royal Society of London. He died in the year 1768, aged 69. As a geometrician and a mathematician he was equalled by few: he was the author of various works on the different branches of the mathematics, the principal of which is the "Cours de Mathématique," from which the present sheets have been selected. The other parts of the same work

are not less important, whether considered on account of the subjects themselves, or of the method in which they are handled. If this part should meet with suitable encouragement from the public, it may lead to a translation of the entire work.

There requires little or no apology for translating the present work; for, although the subject is so important, very little has been published upon it in this country. It is therefore hoped, that this tract will be found highly useful to mechanists in general, and to all persons concerned in wheel-work in particular.

How far the translator has succeeded in rendering it clear and perspicuous, is not his province to determine: he flatters himself that he has conveyed the author's meaning in such a manner as to be readily understood by those who are in the least acquainted with mathematical science; and if his labour proves useful, he shall think the pains he employed on it well bestowed.

THE
EDITOR'S PREFACE

TO THE SECOND EDITION.

ALWAYS feeling annoyed at meeting with a long preface to a book, labouring as it were to beget a prepossession in favour of the author, and standing between the reader and the subject, like an impertinent porter, who detains a visitor at the gate, instead of giving him admission to the presence of the master, the editor will confine himself to five pages of preliminary remarks, on the qualifications which the reader must bring with him, in order to his understanding the investigations and demonstrations of the author; and to give some information respecting the arrangements of the work, and on the tables used in the calculations.

It may be useful to premise that M. Camus, of the Royal Academy of Sciences, Examiner of Engineers, Professor and Secretary of the Royal Academy of Architecture, of Paris, published, in 1752, a "Course of Mathematics," in the second volume

of which, two books, or sections (pages 305 to 428), are devoted to the consideration of the teeth of wheels, pinions, &c.

Those two books were translated into English, and published **thirty years ago**, accompanied by very accurate copies of the fourteen plates given by Camus, in illustration of his subject, to which was prefixed a paper, headed, "Additions to the work of M. Camus," and a plate, explained in the "additions."

In regard to the qualifications, it is necessary that the student be acquainted with such common characters and terms used in algebra, and in trigonometry, as are to be easily learned from books containing the elements of mathematics, one of which may be purchased for sixpence at most of the book stalls.

And, that he should possess a determined resolution to prosecute the mathematical investigations of the subject, with patient and persevering industry; and, if he be a workman, he should feel persuaded, that to be enabled to unite theory with practice, would greatly enhance his value, and would give him a better chance of employment in his old age, by disposing and assisting him to follow the stream of improvement, which must constantly accompany the universal progress of the human mind.

The properly qualified student will be delighted to find, that in Camus nothing is assumed, his progress being marked by a steady and sure making good of every step as he advances; and, in proceeding onwards, his mind will feel itself on secure footing.

It was well said by the late Dr. T. Young, that “unfortunately the hands that execute, are too often unsupported by the head that directs.” To which may be added, that theory without practice, and practice without theory, are equally apt to produce monsters; while theory and practice, legitimately united, may be expected to bring forth the most beautiful and useful results. Let then, the working student make himself master of the theory of Camus, to improve and perfect his own practice.

In respect to the arrangement, it has been deemed expedient to invert the order observed in the first edition, where the “additions” were given before the work itself, to which it purported to be additional; and, therefore, in this second edition, Camus is placed according to his rank, at the head of the work, and the “additions” given in an Appendix, together with some observations tending to eradicate the errors propagated by those “additions,” and to set at rest a controversy which has subsisted for the last thirty years, among me-

chanists, on the proper generating circle of the epicycloid, for forming the teeth of wheels.

The Appendix also treats of the involute curve in a more practical manner than has heretofore appeared; and some experiments are detailed, calculated to throw light on the properties of that curve, and to lead to its more frequent use; and three plates are added, to exemplify the two curves, and to direct the workman in forming them. Thus the whole number of plates is eighteen, namely, fourteen plates, numbered at the upper right-hand corner, from 23 to 36 inclusive, being the same numbers as in the original from which they are copied.

The next plate, 37, is that which was numbered 1 in the first edition. Numbers 38, 39, and 40, are the three new plates.

All the plates are also numbered at the lower right-hand corner, from 2 to 19; the omission of number 1 being occasioned by its removal to the situation of number 16, for reasons given in the Appendix. Plate 23, according to the upper numbers, or 2 according to the lower, is therefore the first plate in the series. The references are all made to the upper numbers.

The tables used by Camus, in his trigonometrical calculations, are those of natural sines, tangents, and secants, that is to say, the numbers

given are decimal parts of radius, as frequently used in France, and commonly published among the French mathematical tables, but seldom resorted to in England, and hence seldom published; the practice here being usually confined to the artificial, or logarithmic sines, tangents, and secants; dispatch being more the order of the day in England than in France.

A very extensive set of tables of natural sines, tangents, secants, and versed sines, form a part of Dr. Charles Hutton's mathematical tables, to which the student may refer to verify Camus's calculations; or he may work with the artificial logarithmic tables, and arrive at the same result in less time.

THE EDITOR.

London, December 16, 1836.

ERRATA.

The student will do well to correct the following errors of the press before he begins to read the work.

- Page 37, line 2, *for* spindles, *read* rungs.
122, 5, *for* 58 minutes, 43 seconds,
read 48 minutes, 58 seconds.
126, 8, *for* of which, *read* which.
178, 4 *from* bottom, *for* stood, *read* stands.

ON THE
TEETH OF WHEELS.

ON THE BEST FORM WHICH CAN BE GIVEN TO THE
TEETH OF THE WHEELS OF A MACHINE.

519.* A MACHINE which does not go uniformly, and whose parts make variable efforts on each other, when a force constantly equal is applied to it, requires, in order to go and to overcome a given resistance, that there should be applied to it a power, the absolute force of which may decrease or increase, according to the situations, more or less favourable, of the pieces of which it is composed; and if it be required, that the force applied to this machine should be constant, the power ought to be capable of moving it in the most disadvantageous situation of its parts. Hence the force which would be sufficient to move a machine in a mean situation, between the one most favourable and the one least favourable to its parts, would not be sufficient to make it go in all situations possible.

* The following sheets being only part (Books X. and XI.) of *M. Camus' Cours de Mathematique*, it has been thought advisable to preserve the same numbers to the chapters, divisions, references, and plates, as are to the original, in order to facilitate any comparison an inquisitive reader may wish to make.

On the other hand, a machine, the parts of which, in regard to each other, are continually in situations equally advantageous, will always go, when there is applied to it a mean moving power, which would be incapable of keeping the former in motion in all the situations which might be given to its different parts.

We may therefore consider as the best form that can be given to the teeth of the wheels of any machine, that which will cause these teeth to be always, in regard to each other, in situations equally favourable ; and which, consequently, will give the machine the property of being moved uniformly by a power constantly equal.

If teeth infinitely small could be given to wheels, their engagement, which might be considered as simple contact, would have the required property ; since the wheel and small cylinder, which in future I shall call *pinion*, have both the same tangential force ; that is to say, the same force to turn when the motion is communicated from the one to the other by mere contact, or by the engagement infinitely small of the parts of their circumferences. The finite and sensible teeth made in those wheels and pinions will then be of that form required, when the wheel moves the pinion or the pinion moves the wheel, in the same manner as if the wheel and pinion only touched each other.

Definitions.

520. When two toothed wheels (fig. 169) act in

each other, the larger is called a wheel, and the less a *pinion*. In water mills the toothed wheels are called, in French, *rouets*; because they are smaller than the water wheel, which is called simply *wheel* (*roue*).

In small machines, the smaller wheels are generally made of one piece, which is divided into several equal parts to form teeth: such small wheels are called *pinions*.

In large machines, instead of pinions of one piece, several cylinders, A, B, C, D, E, &c. (fig. 170) are inserted, at equal distances, parallel to each other, in round pieces of wood, F, G. This assemblage is called a *lantern*, and the round pieces of wood, F, G, are called, in French, *tourtes* or *tourteaux*, (in English, cheeks or heads.)

As pinions and lanterns differ only in their form, and may be employed indifferently for the same purpose, when the engagement of two wheels is spoken of in general, lanterns will be comprehended under the general name of *pinion*.

The teeth of wheels and of pinions are called in general, *teeth*. In small machines, where the teeth are of the same piece with the body of the wheel, they are called properly teeth. In large machines, where the teeth are each made of a separate piece of wood, they are called *cogs*. The teeth of pinions, when of the same piece with the body of the pinion, are called *leaves*; when they consist of cylinders, arranged in circular pieces of wood, so as to compose a lantern, they are distinguished by the names of *rungs*, *staves*, *rounds*, or *roundles*. As the rungs

of a lantern perform the office of teeth, and the cogs of wheels, and the leaves or wings of pinions, are real teeth, when we speak of engagement in general, we shall comprehend under the name of *teeth*, teeth properly so called, cogs, the leaves or wings of pinions, and the rungs of lanterns; and we shall use the terms leaves and rungs only when we speak of pinions, properly so called, or of lanterns in particular.

The right line BF, drawn through the centres B, F, (fig. 169, 171) of a pinion and a wheel, which, act in each other, is called the *line of centres*.

When the line of centres BF is divided into two parts, AB and AF, proportional to the number of the teeth of the pinion and the wheel, these two parts are called the *proportional radii*, or the *primitive radii* of the pinion and the wheel; and if from the centres B and F there be described, with the primitive radii, two circles X and R, these circles will represent a pinion and a wheel, which will touch each other in the point A, where the line of centres has been divided, and be the pinion and wheel which ought to be taken, were they to have teeth infinitely small, or were they to move each other by contact alone. These circles X and R, the radii of which AB and AF are proportional to the numbers of the teeth of the pinion and the wheel, will be called the *primitive pinion and wheel*.

The straight lines BI and FQ (fig. 169) drawn from the centres of the pinion and the wheel to the extremity of their teeth, will be called the *true radii of the pinion and of the wheel*.

It will be seen hereafter, that in pinions which have few leaves or rungs, as 5, 6, 7, 8, and even 9, the true radius ought always to be greater than the primitive radius; and that in pinions which have a greater number of teeth, the true radius and the primitive radius may be of the same size. It will be seen also, that the true radius of a wheel ought to be greater than its primitive radius; because the primitive radii are the radii which the pinion and wheel would have, did they merely touch each other, and were the engagement of the wheel, and the pinion to take place according to the elongation of the primitive radii of these two pieces, or according to the elongation of one of them.

Theorem.

521. *Let BF, (fig. 172, 173, 174, 175, 176, and 177,) be the line of centres of a wheel and pinion, which act in each other. Divide this line into two parts, AB and AF, proportional to the number of the teeth of the wheel and pinion; and with the radii AB and AF, describe the primitive wheel and pinion. If through the point E, where the tooth of the wheel meets with that of the pinion, there be drawn a straight line HI, perpendicular to the common tangent of these two teeth, or to the curvature of one of them, and if this perpendicular meet with the line of centres in any point K, we shall have this proportion.*

The force with which the circumference R of the primitive wheel will turn, and would move the circum-

ference X of the primitive pinion, did it move it by the point of contact A,

Is to the force with which the circumference of the primitive pinion will turn, when the teeth of the wheel move it by the point E,

As the product of $AB \times KF$,

Is to the product of $KB \times AF$.

Demonstration.

Let R represent the force of the circumference of the primitive wheel, and let P denote the force which the circumference X of the primitive pinion will have when the tooth of the wheel moves it by the point E: it is required to demonstrate that we shall have this proportion:

$$R : P :: AB \times KF : KB \times AF.$$

Since the tooth of the wheel and that of the pinion touch in the point E, the force of the wheel will be communicated to the pinion in the point E, in the direction of the line IEH, perpendicular to the common tangent of the two teeth. But if from the centres F and B of the wheel and pinion there be drawn two lines, FI and BH, perpendicular to the straight line HI; and if I be called the force with which the point I of the wheel will turn; as HI will be a tangent to the circle which might be described by the point I on the plane of the wheel, the force I of that point will be communicated to the pinion by the point E, in the direction IEH. But IEH being perpendicular to the straight line BH, drawn from the centre B of the pinion, it will

be the tangent also of the circle which has BH for radius, and the force I being communicated to this circle by the tangent IH, will be the force with which the point H will turn.

The letter R having been assumed to represent the force with which the circumference of the primitive wheel or the point A will turn, and the letter I denoting the force of the point I in the plane of that wheel, we shall have $R : I :: IF : AF$.

Since the letter I represents also the force with which the point H of the pinion will turn, and as P denotes the force with which the circumference X, or the point A of the primitive pinion will turn, in consequence of the force I with which the point H of the pinion turns, we shall have $I : P :: AB : HB$.

Multiplying the two last proportions in their order, we shall have, $R : P :: AB \times IF : AF \times HB$.

But the right angled triangles KFI and KBH being similar, give $IF : HB :: KF : KB$

And $AB : AF :: AB : AF$

Hence, if these two proportions be multiplied in order, we shall have

$AB \times IF : AF \times HB :: AB \times KF : KB \times AF$

Then, since $R : P :: AB \times IF : AF \times HB$

We shall have also $R : P :: AB \times KF : KB \times AF$ Q. E. D.

Corollary I.

522. We have supposed in this theorem that the wheel drives the pinion (fig. 172, 173, 174, 175,

176, and 177) ; but it is evident that the case will be the same when the pinion drives the wheel. If P then be the force with which the circumference of the primitive pinion makes an effort to turn, such a force for turning R will be produced, at the circumference of the primitive wheel, that we shall have $P : R :: KB \times AF : AB \times KF$.

Corollary II.

523. If the point K (fig. 173, 176), where the straight line HEI meets with the line of centres, be between the centre of the wheel and the point A, where the primitive wheel and the primitive pinion touch each other, we shall have $KB > AB$ and $AF > KF$; consequently $KB \times AF > AB \times KF$. But it has been found that $R : P :: AB \times KF : KB \times AF$; we shall therefore have $P > R$; that is to say, the circumference of the primitive pinion will turn with more force than the circumference of the primitive wheel, whether the wheel drive the pinion or the pinion the wheel.

Corollary III.

524. If the point K, where the straight line HEI (fig. 172, 175) intersects the line of centres, be between the centre B of the pinion and the point A; where the primitive circles of the wheel and pinion touch each other, we shall have $AB > KB$ and $KF > AF$; consequently $AB \times KF > KB \times AF$; and as it has been found that $R : P :: AB \times KF : KB \times AF$, we shall have $R > P$; that is to say, the circumference of the primitive wheel will turn with

more force than the circumference of the primitive pinion.

Corollary IV.

525. When the point K (fig. 174, 177), where the straight line HEI intersects the line of centres, coincides with the point A, which separates the two primitive radii of the wheel and pinion, we shall have $AB = KB$ and $KF = AF$; consequently $AB \times KF = KB \times AF$, since each of these products will become $AB \times AF$; and as we have $R : P :: AB \times KF : KB \times AF$, we shall have $R = P$; that is to say, the circumference of the primitive wheel and that of the primitive pinion will turn with the same force, whether the wheel drives the pinion or the pinion the wheel.

Corollary V.

526. It has been already said, that we may consider as the best figures which can be given to the teeth of wheels and pinions, those which cause the wheel and pinion to have at their circumference the same force for turning; because in this case the wheel and pinion move each other in the same manner as if they merely touched. But it has been seen, in the last corollary, that the wheel and pinion will have, at their primitive circumferences, the same force for turning, when the straight line HEI (fig. 174, 177) drawn through the point of contact E of two teeth, perpendicular to their curvature, passes through the point A, which separates the two primitive radii of the wheel and the pinion.

We ought, therefore, to consider as the best forms which can be given to the teeth of wheels and pinions, those which act in each other in such a manner, that the line perpendicular to the parts which touch, may always pass through the same point A, where the primitive radii of the wheel and pinion terminate in the line of centres.

Corollary VI.

527. The point K then (fig. 173, 176), where the line of centres will be intersected by the straight line HEI, will fall within the wheel, when the circumference of the primitive pinion turns with more force than that of the primitive wheel; for it has been seen (524) that if the point K were within the pinion, the circumference of the wheel would turn with more force than that of the pinion; and (525) that if the point K were in the point A, the primitive circumferences of the wheel and pinion would turn with equal force.

We shall prove, in the like manner, that the point K will be within the pinion (fig. 172, 175) when the circumference of the primitive pinion turns with more force than that of the primitive wheel.

In the last place, we shall prove also, that the point K (fig. 174, 177) will coincide with the point A, when the primitive circumferences of the wheel and pinion turn with equal force.

Remark.

528. As the force which the circumference of the primitive pinion has for turning (fig. 173,

176) is greater than that with which the circumference of the primitive wheel turns, when the point K, where the straight line HEI cuts the line of centres, is within the primitive wheel, it will perhaps be said that, in the case where the wheel moves the pinion, it will be advantageous to give to their teeth such a form that in touching, the perpendicular HEI may meet the line of centres within the wheel (fig. 172, 175). It will be said also, perhaps, that it will be advantageous to give to the teeth such curvatures, that the straight line HEI, drawn through the point of their contact, perpendicular to their curvature, shall intersect the line of the centres in a point K, situated within the primitive pinion ; because the circumference of the primitive wheel will then turn with more force than that of the pinion.

This objection would be valid, were it possible, in all positions of the wheel and pinion, to cause the straight line HEI, perpendicular to the parts of the teeth which touch each other, to meet always with the line of centres within the primitive wheel when the wheel moves the pinion ; and always to cut the line of centres within the primitive pinion when the pinion moves the wheel ; but this is impossible ; and it is easily shewn, that if in any positions of the teeth of the wheel and pinion the line HEI, perpendicular to the contact of those teeth, cuts the line of centres within the wheel, there will necessarily be other situations of the teeth in which the perpendicular HEI will cut the line of centres within the pinion ; and, recipro-

cally, if there be positions of the teeth in which the perpendicular HEI cuts the line of centres within the pinion, there will be others in which the same perpendicular will meet with the line of centres within the wheel. If any thing, therefore, be gained by making the perpendicular HEI cut the line of centres within the primitive wheel or within the primitive pinion, something will afterwards be lost when the perpendicular HEI cuts the line of centres within the primitive pinion or the primitive wheel; so that a less constant power will be necessary to cause the pinion to be moved by the wheel or the wheel by the pinion, when the perpendicular HEI always cuts the line of centres in the common term A of the primitive radii of the wheel and pinion, than when this perpendicular does not constantly pass through the point A; a demonstration of this truth will be seen hereafter (534).

Theorem.

529. *The line of centres BF (fig. 172, 173, 174, 175, 176, 177), being divided into two parts, AF and AB, proportional to the number of the teeth of the wheel and the pinion, as in the preceding theorem, so that AF and AB, shall be the primitive radii of the wheel and pinion, and if a straight line HEI be drawn through E, the point of contact of the teeth, perpendicular to their common tangent, so as to meet with the line of centres in any point K, we shall have this proportion:*

The velocity with which the circumference R of

the primitive wheel will turn and move the circumference X of the primitive pinion, if it moves it by mere contact,

Is to the velocity with which the circumference X of the primitive pinion will turn, when the teeth of the wheel move it in the point E,

As the product $KB \times AF$

Is to the product $AB \times KF$.

Demonstration.

Let V represent the velocity of the circumference of the primitive wheel, or the space passed over by a point of that wheel in an instant, and let v be the velocity of the circumference of the primitive pinion, or the space passed over by a point of its circumference, while a point of the circumference of the primitive wheel passes over the space V . It is here to be demonstrated, that we shall have $V : v :: KB \times AF : AB \times KF$.

Through the centres F and B of the wheel and pinion draw FI and BH , perpendicular to the straight line HEI , which will then be a tangent to the two circumferences described with the radii FI and BH . This straight line, therefore, will be the common direction of the infinitely small spaces, which will be described in the same time by the points I and H ; because the infinitely small arc which may be described by these points will be confounded with their tangents. Moreover the small spaces passed over in the same time by the points I and H will be equal; since the point H will proceed in the same direction as the point I , through

which it is supposed to be impelled by means of the right line IH; and it is evident that two bodies, one of which impels the other, have the same velocity when they pursue the same direction. Hence, if I represent the velocity which the plane of the wheel has in the point I, I will be the velocity also of the point H of the pinion.

The arcs described by the two points A and I, attached to the plane of the same circle R, will be similar, and consequently proportional to the whole circumferences which these points can describe; and these circumferences will be proportional to their radii AF and IF. Therefore, since V represents the velocity of the point A, or of the circumference R, and I that of the point I, we shall have $V : I :: AF : IF$.

For the same reason, the spaces passed over by the points H and A, attached to the pinion, will be proportional to their distances HB and AB from the centre of the pinion; and as I is the space passed over by the point H or the velocity of that point, and as v represents the velocity of the point A of the pinion, we shall have this proportion $I : v :: HB : AB$.

Now if we multiply these two proportions in order, we shall have $V : v :: AF \times HB : IF \times AB$.

But the similar right angled triangles KBH and KFI will give, $HB : IF :: KB : KF$

And $AF : AB :: AF : AB$

Therefore, if the two last proportions be multiplied in order, we shall have,

$AF \times HB : IF \times AB :: KB \times AF : AB \times KF$

Then since $V : v :: AF \times HB : IF \times AB$

We shall have also $V : v :: KB \times AF : AB \times$

KF q. e. d.

Corollary I.

530. Though we have supposed in this theorem (fig. 172, 173, 174, 175, 176, 177) that the pinion is driven by the wheel, it is evident that the same proportion will be found when the wheel is driven by the pinion; that is to say, we shall have $V : v :: AB \times KF : KB \times AF$.

Corollary II.

531. We have seen (521) that by making R (fig. 172, 173, 174, 175, 176, 177) to represent the force of the circumference of the primitive wheel, and P the force of the primitive pinion, we shall have

$$R : P :: AB \times KB : KF \times AF.$$

And we have found (529),

$$V : v :: KB \times AF : AB \times KF.$$

Hence, multiplying these two proportions in order, we shall have

$$R \times V : P \times v :: AB \times KB \times KF \times AF : AB \times KB \times KF \times AF.$$

And consequently $R \times V = P \times v$; that is to say, the product of the force and the velocity which the circumference of the primitive wheel has, at each instant, is equal to the product of the force and the velocity which the circumference of the pinion has at the same time, during each instant of

its motion. If we, therefore, call these two products the momenta of the primitive circumferences of the wheel and pinion, it may be said that these primitive circumferences have always in the same time equal momenta, whether the wheel moves the pinion or the pinion the wheel.

Corollary III.

532. Since $R \times V = P \times v$ (fig. 172, 173, 174, 175, 176, 177) we shall have $R : P :: v : V$; that is to say, the contemporary forces of the primitive circumferences of the wheel and of the pinion, engaged with it, are reciprocally proportional to their contemporary velocities.

It thence follows, that as the force with which the circumference of the primitive wheel becomes greater than that with which the circumference of the primitive pinion turns, the velocity of the circumference of the primitive wheel will become less than that of the circumference of the primitive pinion. Thus when the point K (fig. 173 and 176) is within the primitive wheel, and (523) the force with which the circumference of that wheel turns is less than the force with which the circumference of the primitive pinion turns, the velocity of the circumference of the primitive wheel will be greater than the velocity of the circumference of the primitive pinion; on the other hand, when the point K is within the primitive pinion (fig. 172 and 175) and (524) the force with which the circumference of the primitive wheel turns is greater than that with which the circumference of the primitive pinion

turns, the velocity of the circumference of the primitive wheel will be less than that of the circumference of the primitive pinion.

Corollary IV.

533. Since the line of centres BF (fig. 172, 173, 175, and 176) has been divided into two parts AF and AB, proportional to the number of the teeth of the wheel and of the pinion, and as the primitive circumferences R and X of the wheel and pinion are in the same ratio as AF and AB, which are their radii, these primitive circumferences R and X are proportional to the number of their teeth; and consequently, if we take for each tooth a full and vacant space, as ought to be the case, the primitive arc, corresponding to each tooth of the wheel, will be equal to the corresponding primitive arc of each tooth of the pinion; and as each tooth of the wheel is obliged to move a tooth of the pinion, or ought reciprocally to be moved by a tooth of the pinion, the primitive arcs passed over by two corresponding teeth of the wheel and the pinion, while the one moves the other, must necessarily be equal. It thence follows, that if there be some instants during which the tooth of the wheel moves faster than the corresponding tooth of the pinion, there will be other instants during which the tooth of the wheel will move slower than that of the pinion; and, reciprocally, if there be any disposition of the teeth during which the tooth of the wheel goes slower than that of the pinion, there will be others during

which the same tooth of the wheel will move faster than that of the pinion.

Corollary V.

534. All the contemporary velocities (fig. 172, 173, 175, and 176) of the primitive circumferences of the wheel and pinion being reciprocal to the contemporary forces which they have to turn, it follows from the last corollary, that if in some positions the primitive circumference of the wheel turns with more force than that of the pinion, there will necessarily be others during which the same primitive circumference of the wheel will turn with less force than that of the pinion; and, reciprocally, if there be some instants during which the primitive circumference of the wheel turns with less force than that of the pinion, there will be others during which it will turn with more force than that of the pinion.

But when the point K, where the straight line HEI cuts the line of centres, is within the circle of the primitive pinion, the primitive circumference of the wheel will turn with more force than that of the pinion (524); and when the point K is within the primitive wheel, the circumference of that wheel will turn with less force than that of the primitive pinion (523); and, reciprocally (527), when the primitive circumference of the wheel turns with more force than that of the pinion, the point K will be within the primitive pinion. On the other hand, when the circumference of the primitive pinion

turns with more force than that of the wheel, the point K is within the primitive wheel (527).

Therefore, if during some instants the point K, where the straight line HEI cuts the line of centres, be within the pinion, there will necessarily be others during which this point K will be within the wheel; and reciprocally if the point K be at some instants within the primitive wheel, there will be other instants during which this point K will be within the primitive pinion. This consequence is what we before promised to demonstrate (528).

It thence follows, that if something is gained by causing the point K to fall within the primitive wheel, or within the primitive pinion, to give the pinion an advantage over the wheel, or the wheel an advantage over the pinion, the contrary will afterwards take place; that is to say, the point K will afterwards fall within the primitive pinion, or within the primitive wheel, and then the wheel will have an advantage over the pinion, or the pinion over the wheel; consequently what was gained will be lost.

Corollary VI.

535. We may then consider (fig. 174, 177,) as the most advantageous form that can be given to the teeth of the wheels and pinions of a machine, those which cause the primitive circumferences of the wheel and pinion to have the same force and the same velocity to turn; and which consequently are curved in such a manner, that the perpendicular HEI, drawn through the point where their teeth

are in contact, shall meet with the line of centres in the point A, where the primitive radii of the wheel and pinion terminate. For when the teeth of the wheel and pinion are thus formed, the wheel, in order that it may move the pinion, does not require the application of so great a force as when they are formed in any other manner ; since, if to procure the same force to the pinion by lessening the power applied to the wheel, the straight line HEI should be made to cut the line of centres within the wheel, it would be requisite to apply to the wheel a power greater than that given to the pinion when the straight line HEI cuts the line of centres BF within the pinion, which will necessarily be the case.

Definitions.

536. Let there be two circles in the same plane CNP and CALMK (fig. 178, 179), which touch each other in C ; if the former be made to revolve on the circumference of the latter, and if we suppose a style or tracing pin fixed in the point C of the circumference of the revolving circle, the style C, during this motion, will describe on the immoveable plane of the circle CALMK a curve CEGDK, which is called an *epicycloid*.

The circle CNP, which in revolving describes the epicycloid, is called the *generating circle* ; and the arc CALMK of the immoveable circle, on which the generating circle revolves, is called the *base of the epicycloid*.

When the generating circle revolves without the

circle of its base, as in fig. 178, the epicycloid is called an *external epicycloid*; and when it revolves within the circle of its base, as in fig. 179, the epicycloid is called an *internal epicycloid*.

Corollary I.

537. As the generating circle in revolving and passing successively from its first situation CNP (figs. 178 and 179) to different positions AEF, LGH, &c. applies, in succession, all the parts of its circumference to those of its base, it is evident that the base CALMK of the epicycloid is equal to the circumference of the generating circle CNP; and that each portion, such as CA or CL, &c. of the base, is equal to each part EA or GL, &c. of the generating circumference, which rolls upon it.

An epicycloid, therefore, may be described, or any number of points in that curve may be found, by describing circles AEF, LGH, &c. having all the same radius as the generating circle CNP, and touching the base CALMK in any points AL, &c.; and by making the lengths of the arcs AE, LG, &c. taken from the points of their contact with the circle of the base equal to those of the arcs CA, CL, &c. of the base comprehended between the same points of contact A, L, &c. and the commencement C of the epicycloid. For having thus determined any number of points, at pleasure, as E, G, &c. the curve CEGDK, drawn through these points and the commencement C, where we suppose the style to have been placed when the generating circle began to revolve, will be an epicycloid.

Corollary II.

538. When the generating circle CNP (fig. 180) of the epicycloid revolves within the circle of its base, and has for diameter the radius CB of its base, the point C , where we suppose the style to be placed, does not fall without the diameter CBK of the circle of its base: hence the epicycloid described by the style C is a diameter of the circle of the base: to prove it, nothing is necessary but to shew, that when the generating circle in revolving has reached any situation AEB , which may represent all the rest, the style C cannot be otherwise situated than in the point E , where the circumference of the generating circle, which has revolved, is met by the diameter CBK .

The generating circle CNP having attained to any situation AEB , where it touches the circumference of its base in A , let us suppose that the point C , where the style is fixed, to be situated in any point O , different from the point E : the length of the arc AC will be equal to that of the arc AO ; since the arc AO will have rolled over the arc AC . But as the radius of the arc AC is double that of the arc AO , the number of the degrees of the arc AO will be double that of the degrees of the arc AC ; and the circumference of the circle AEB will pass through the centre B of the circle CAK . The angle CBA then, which has its summit at the centre B of the circle of the base, and which consequently is measured by the whole arc AC , comprehended between its sides, will be equal to the angle OBA , which has its summit at the same



point B of the circumference of the circle AEB ; and which therefore is measured by half the arc AO. But it is impossible that the angle CBA should be equal to the angle OBA, unless the point O, at which the style is supposed to have arrived, be in the point E, where the diameter CBK meets with the circumference of the revolving circle AEB. The generating circle then having attained to any situation whatever, AEB, the style C cannot be otherwise than in the point E, where the diameter CBK meets with the circumference of the generating circle in its position AEB ; consequently when the generating circle of the epicycloid revolves within the circle of its base, and has for diameter the radius of its base, the style C does not go beyond the diameter CBK ; the epicycloid therefore, described by the style C, is a diameter of the circle of its base.

Corollary III.

539. The generating circle of the epicycloid being in any position whatever AEB (fig. 181), and touching the circle of its base in any point A, if through the point of contact A and the point E, which describes the epicycloid, there be drawn a straight line AE, this straight line will be perpendicular to the curvature of the epicycloid in the point E.

To prove it, let us suppose that the generating circle and the circle of its base are regular polygons of an infinite number of equal sides, applied

to each other, and the summits of whose angles successively join, while the generating polygon revolves on its base. When the summit A of any angle of the generating polygon turns on the summit A of an angle of the polygon of the base, as on a fixed point, the point E, which describes the epicycloid, will trace out a small arc of a circle, having the point A for its centre, and the straight line AE for its radius. But a radius is always perpendicular to the arc described by its extremity; AE then is perpendicular to the small portion of the epicycloid described by the style E, in the position in which it is.

Corollary IV.

540. The generating circle of the epicycloid being in any position AEB (fig. 181), and revolving on the base CA, if the centres of these two circles be joined by a straight line FG, the prolongation of which GB meets with the circumference of the generating circle in a second point B, and if through the point B there be drawn a straight line BE to the point E, where the circumference of the generating circle meets with the epicycloid towards its origin C, this straight line BE will touch the epicycloid in the point E; for it will touch the small arc of a circle described by the point E, while AE turns on the point A as on a fixed point; and the small arc described by the point E may then be considered as a small part of the epicycloid.

Corollary V.

541. Let us suppose in the same plane three circles R, X, and Y (fig. 182), which touch each other in the point A, and whose centres F, B, G, are consequently in a straight line; if one of these circles be made to revolve around its centre, and it forces the other two to turn around their centres, which we suppose to be fixed, moving these circles by the point of continual contact A, common to the three circumferences, it is evident that all the parts of the circumference of the circle made to revolve will be applied in succession to every part of the circumferences of the other two circles, in the same manner as if the two circles R and X remained immovable, while the third Y revolved on the circumferences of the first two. Hence, if we suppose a style fixed to the circumference of the circle Y alone, moveable around its centre, the three circles having been obliged to turn by the motion of the one which has carried along the other two; when the style is in E, if each of the two arcs AC and AH be made equal to the arc AE, the style placed in E will have described on the moveable plane of the circle R, on the exterior part of which it revolves, a portion CE of an exterior epicycloid, and on the moveable plane of the circle X, within which we may consider it to revolve, a portion HE of an interior epicycloid.

These two epicycloids, traced out at the same time by the style E, affixed to the circumference

of the circle Y, will touch each other in the point E. For the straight line AE, drawn through the point A, where the generating circle Y touches its bases R and X, will be perpendicular to the two epicycloids; and the straight line *b* E will touch these two epicycloids in the same point E (540).

Corollary VI.

542. Let us now suppose that the generating circle Y (fig. 183) has for diameter the radius AB of the circle X, within which it is; and that these circles R, X, and Y, touch continually in the point A: the interior epicycloid HE, which will touch the exterior CE, will be a straight line directed towards the centre B of the circle X, and consequently will be a portion of the radius BH, which will always touch the exterior epicycloid CE in the point E, where this radius meets with a perpendicular AE, drawn to it from the point A.

It thence follows, that when two circles R and X continually touch each other, and the one obliges the other to turn around, carrying it along by the point of contact A, if we suppose a radius BH in the circle X, and, having made AC = AH, we describe through the point C, taken at its commencement, an exterior epicycloid CE, having for its generating circle, a circle Y, the diameter of which is equal to the radius BH, this radius BH during the motion of the two circles R and X will always touch the epicycloid CE in the point E, where the epicycloid is intersected by the straight line AE, perpendicular to its curve. Hence, instead of sup-

posing that one of the two circles R and X moves the other by the point of contact A, the radius BH of the circle X may be made to be impelled by an epicycloid CE, attached to the circle R, and described by the motion of the circle Y, the diameter of which is equal to the radius BH; reciprocally also, the epicycloid CE attached to the circle R might be made to be impelled by a radius BH of the circle X, and by means of the epicycloid CE and the radius BH, the two circles R and X might move each other as if impelled by the point of contact A.

It is from this corollary chiefly, that we shall deduce the best form which can be given to the teeth of the wheels and pinions of a machine, in which a part of the tooth of the wheel or pinion, or of the teeth of both, ought to be formed in a straight line, tending to the centre of the wheel and the pinion.

Corollary VII.

543. If in the same plane (fig. 182 and 183) there were only two circles R, Y, touching each other in the point A, and if the motion of the one were communicated to the other by the point of contact, any point E of the circumference of the circle Y would describe, on the moveable plane of the circle R, an epicycloid CE; and this epicycloid, which we suppose to be attached to the circle R, would move the circle Y, impelling it by the point E of its circumference, in the same manner as the circle R might move the same circle Y, communicating motion to it by the point of contact A; and

reciprocally the point *E* of the circumference of the circle *Y*, turning around its centre *G*, would cause to revolve the circle *R*, impelling it by the epicycloid *CE*, which we suppose to be attached to this circle *R*; in the same manner *Y* would move the circle *R* by communicating its motion in the point of contact *A*.

From this corollary we shall deduce the best form that can be given to the teeth of a wheel, when the pinion is a lantern composed of rungs; we shall deduce from it also the most advantageous form that can be given to the teeth of a pinion, when the wheel has rungs parallel to each other instead of teeth.

Problem.

544. *The number of the teeth of a wheel, and the number of the rungs of a lantern (fig. 184), in which the wheel is to act, being given, with the distance of their centres *F* and *G*, to determine the primitive radius and the true radius of the wheel; the size and form of the teeth and the depth of the engagement of the teeth of the wheel in the lantern.*

Solution.

As one example will be sufficient to give an idea of this problem, and as one solution for indeterminate numbers of teeth and rungs might render it obscure, without making it easier to be applied to wheels and lanterns, the numbers of the teeth and rungs of which are given; we shall suppose that the wheel ought to have thirty teeth, the lantern eight rungs; and that the centres *F* and *G* of the

wheel and the lantern ought to be at the extremities of the given straight line FG.

Since the wheel ought to have thirty teeth, and as a lantern of eight rungs is required, we must divide the line of centres FG into two parts, AF and AG, which shall be to each other as thirty to eight, or as fifteen to four. For this purpose, divide the straight line FG into thirty-eight equal parts; that is to say, into as many parts as there are teeth and rungs together in the wheel and in the lantern; and having taken eight parts for AG, and the remaining thirty for AF, the straight lines AF and AG will be the primitive radii of the wheel and the lantern.

The primitive radii of the wheel and the lantern being thus determined, the next thing is to determine the form of the teeth, and this form will give the true radius of the wheel.

To determine the form of the teeth, which always depends on that of the rungs, we shall first suppose that the rungs are infinitely small, and represented on the circular plane, forming the end of the lantern by eight points, A, E, H, I, K, *i*, *h*, *e*; and when we have found the form of the teeth proper for moving these rungs infinitely small, which cannot be used in practice, we shall correct it; and by its means trace out the real form which must be given to the teeth of wheels, to drive lanterns with cylindric rungs. Hence the solution of the proposed problem will be divided into two parts.

I.

FOR THE FORM OF THE TEETH OF A WHEEL WHEN
THE RUNGS OF THE LANTERN ARE INFINITELY
SMALL.

545. We have seen (543) that if the circle $CA\ c$ (fig. 184), which touches the circle $EA\ e$ were furnished at its circumference with an epicycloid $c\ E$, described by the point E of the circumference of the circle $EA\ e$, during the revolution of that circle on the circle $CA\ c$, the epicycloid $c\ E$ would move the circle $EA\ e$ by the point E , in the same manner as the circle $CA\ c$ would move it by the point of contact A .

It has been seen also, and it is evident, that if the two circles $CA\ c$ and $EA\ e$ moved each other by their point of contact A , these circles would both have the same velocity; hence, when the epicycloid $c\ E$ moves the circle $EA\ e$ by a point E of its circumference, the circumferences of the two circles $CA\ c$ and $EA\ e$ will have the same velocity; consequently the same force (535). The epicycloid $c\ E$ is, therefore, the best curve that can be given to the tooth of a wheel to drive a lantern, the rungs of which are infinitely small.

Considering only the epicycloid $c\ E$, and the property it has of causing the primitive lantern to revolve with the same velocity, and the same force as the primitive wheel, moving the lantern by a point E , which represents a rung infinitely small, it is evident that it is the convex side of the epicycloid

which will move the rung or point E , when the rung is driven from A towards E , and removes from the line of centres ; and it will be its concave side which moves the point E , when that point is driven from E towards A , and approaches the line of centres.

But if we reflect that the teeth of the wheel must be engaged one after the other in the lantern, and that each tooth of the wheel after moving a rung must escape from the lantern, and ought not to prevent the following tooth from moving the next rung, it will be readily perceived, that it is not possible that the concave side of the epicycloid cE can move the spindle E of the lantern ; consequently it is impossible that the epicycloid should cause the lantern to revolve by bringing near to the line of centres the rung which it moves. For let us suppose that the concave side of the epicycloid cE has moved the rung E as far as A , and that it has arrived at the position AB : it cannot continue to move the rung from A towards e , because it is supposed to be concave on the side on which it moves the rung, and because it would require to be convex, as AD , to remove the rung from the line of centres, and to carry it from A towards e . Moreover the rung A being hooked in the epicycloid AB , this epicycloid cannot disengage itself from the lantern to allow another epicycloid to move another rung E . Hence it is impossible that the teeth of a wheel can be formed into a concave epicycloid on that side on which they move the rungs, if it be required that the circumference

of the primitive lantern should have the same velocity and the same force as the circumference of the primitive wheel ; consequently it is impossible also that the rungs of a lantern should be moved by a wheel, before they have arrived at the line of centres.

Since an epicycloid cannot move a rung towards the line of centres, the epicycloid cE must necessarily move the rung E from A towards E , until a second rung has reached A in the line of centres, and is caught by a second epicycloid AB , which will also move the rung A , until another rung e has attained to the same line of centres ; and the case will be the same with other rungs of the lantern and other teeth of the wheel.

If it be required that the wheel should drive the lantern on both sides, that is, from A towards E and from A towards e , it is evident that each tooth of the wheel ought to have the two opposite sides cE and LM formed into equal epicycloids, similar and opposite, and that the tooth $cEML$ ought to be sufficiently long to move the rung E , until the next rung has reached the line of centres.

As it is here supposed that the rungs of the lanterns are infinitely small, if the teeth of the wheel were completely formed and equally spaced, as well as the rungs of the lantern, spaces infinitely small only, would be necessary between the teeth of the wheel to receive the rungs : but as perfect precision cannot be attained, it will be necessary to leave between the teeth small spaces, such as AL , for the play of the teeth of the wheel

in the lantern ; that is to say, that the wheel may move the lantern, notwithstanding the small inequalities of the teeth and the rungs. As this space AL ought to be proportioned to the inequalities which are always unknown, it cannot be exactly determined ; but it is better to make it too large than too small.

It has here always been supposed that the teeth of the wheel move the rungs of the lantern ; but it is evident that the teeth of the wheel must have the same form when they are moved by the rungs. It is only necessary to remark, that the rungs of the lantern will move the teeth of the wheel in proceeding towards the line of centres, and will leave them when they have reached that line ; whereas the teeth of the wheel would move the rungs by removing them from the line of centres, and after they had attained to that line.

It results from what has been said, that to determine the form of the teeth of a wheel which ought to move a lantern with rungs infinitely small, or which ought to be moved by this lantern, we must first determine the primitive radii AF and AG of the wheel and lantern, and describe their primitive circles, CA *c* and EHIK *i h e A* ; then divide the primitive circle of the wheel into as many equal parts AC, A *c*, &c. as it ought to have teeth ; that is to say, into thirty : supposing, as we have done, that the wheel is to have thirty teeth, and divide the circle of the primitive lantern into as many equal parts as the lantern is to have rungs ; that

is to say, into eight, as it ought to have eight rungs. We may then determine the space AL , which ought to be left between the teeth of the wheel, making it larger or smaller, according as the wheel and lantern are more or less perfect; but this must depend on the sagacity of the engineer who is to conduct the machine, and the opinion he forms of the skill of the workman by whom it is to be constructed. All the spaces AL , NC , &c. which ought to be between the teeth, being fixed, and the feet cL , AN , &c. of all the teeth being consequently determined on the circumference of the primitive wheel, describe, through the extremities of the feet of each tooth, epicycloids, having for base the circumference of the primitive wheel, and for generating circle the primitive circle of the lantern. For example, cL being the foot of one tooth, describe, through the extremities c and L of that foot, two opposite epicycloids cEP and LMP , which will turn their convexities towards the neighbouring teeth, and which having for base the circle CAc , will have for generating circle the circle $EHIK$ *i h e A*. Two similar epicycloids, equal and opposite ABQ and NOQ , must be described through the extremities A and N of the foot AN of another tooth, and proceed in the same manner with the rest.

When epicycloids have been described through the extremities of the feet of all the other teeth, each space cPL or AQN , &c. comprehended between two opposite portions of an epicycloid, and

the foot of a tooth will be the form which the thirty teeth of the wheel ought to have to drive the lantern with eight rungs infinitely small.

Each tooth of the wheel as c PL being formed by two opposite epicycloids c EP and LMP, which mutually terminate at the place P where they meet; it is evident that the straight line FP, drawn from the centre of the wheel to the point P, where the two epicycloids of the same tooth meet, is the greatest true radius that the wheel can have, in regard to the space AL, which has been left between the two neighbouring teeth c PL and AQN.

When the rung E has been moved till the next rung A is in the line of centres, the rung A may, in its turn, be moved by the tooth AQN; and then it will no longer be necessary that the rung E should be moved by the tooth c PL: the whole quantity EPM may therefore be taken from the tooth c PL, and the part c EML only be retained for the tooth. Hence a rung A being in the line of centres, the straight line EF drawn through a rung E, near that which is in the line of centres, and through the centre F of the wheel, will be of sufficient length to be the true radius of the wheel. But this straight line EF being the shortest true radius which the wheel can have, we may take as the true radius of the wheel any number of different lines at pleasure, provided they are not greater than FP nor less than EF.

When the true radius of the wheel, which must be made greater than EF and less than FP, to avoid falling into extremes has been determined,

it is to be taken from the primitive radius $c F$, or AF , and the remainder will be the quantity of the engagement of the wheel in the lantern.

II.

To determine the Figure of the Teeth of the Wheel, when the Rungs of the Lantern are Cylinders of a finite Diameter.

546. We shall first consider the lantern as if it had rungs infinitely small (fig. 185), represented by the centres A, E, H, I, K, i, h, e , of the small circles, which are sections of the rungs, perpendicular to their axes; and we shall trace out, as already said, the teeth $CPL, AQN, \&c.$ of the wheel as if it had to move a lantern with rungs infinitely small, taking care to leave between all the teeth, for the play of the engagement, a small space as AL . We shall then reform all these teeth, to make them agree with the rungs of a finite diameter, which the lantern ought to have.

If the radius of the rungs, which we suppose equal, be given, describe with this radius, on the plane of each tooth, as many small arcs as possible, having all their centres in the two epicycloids which form that tooth; and through all these arcs trace out two curves, such as RO and SO , parallel to the epicycloids between which the first teeth are included. These new curves, RO and SO , or TY and VY , being thus described, will reform the first teeth $CPL, AQN, \&c.$; and will comprehend, between them and the primitive circle of the wheel, spaces, $ROS, TYV, \&c.$ which will be the figures

of the teeth which the wheel ought to have, to drive the ^{rungs} spindles A, E, H, I, K; *i, h, e*, the diameters of which are given. The demonstration is as follows :

If we suppose that the centre E of a rung is moved by the tooth CPL, the curve RO, which is parallel to the epicycloid CP, and whose distance from it is equal to the radius of the rung E, will always touch the circumference of that rung ; hence the curve RO will move the cylindric rung in the same manner as the tooth CPL, formed by two epicycloidal portions, would move the centre E of that rung ; consequently the tooth ROS will have the form proper for moving a lantern with cylindric rungs. It is evident that if all the rungs of the lantern are of the same diameter, the other teeth of the wheel, being formed in the same manner as the tooth ROS, will have also the figure which they ought to have in order to drive the lantern.

When the radius of the rungs of the lantern is not given, if it be necessary to correct the first teeth of the wheel CPL and AQN, in such a manner that the new teeth shall leave between them spaces equal to the breadth of their feet ; and if it be required that the play of the engagement should always be equal to AL, divide the foot of the tooth CL into two equal parts CD and DL, and having taken on both sides of the point D two parts, DR and DS, equal to the fourth part of the arc AC, the arc RS will be the foot of the new tooth required. Then with a radius equal to the

chord of the arc CR, trace out the circles A, E, H, I, K, *i*, *h*, *e*, which will represent the size of the rungs of the lantern. In the last place, to complete the correction of the first teeth of the wheel, describe with the same radius, on the plane of each of them, as many small arcs as possible, having their centres in the epicycloids which inclose the first teeth; and if through all these small arcs there be drawn curves, such as RO and SO, or TY, and VY, we shall have new teeth ROS and TYV, which will leave between them spaces equal to the breadth of their feet; which, while acting in each other, will have the play required; and which will drive the rungs, the size of which has been determined, in the same manner as the former teeth would have driven rungs infinitely small.

As the two curved sides of each of the new teeth mutually terminate in meeting, it is evident that the distance OF of the point of one of these new teeth from the centre of the wheel, will be the greatest true radius that the wheel can have.

When a rung E has been moved till the centre A of the next rung is in the line of centres GF, the rung A may be moved in its turn by the following tooth TYV; and in this case it will no longer be necessary that the tooth ROS should move the cylindric rung E. The tooth ROS may therefore be terminated at the point X, where it touches the rung E, when the centre of the next rung is in the line of centres; and the distance XF from that point of contact to the centre of the

wheel will be the least true radius that the wheel can have.

To determine the point X , where the tooth ROS touches the rung E , draw through the centre of that rung and the point A , the straight line EA : the point X , where the line EH meets with the circumference of the cylindric rung, will be that where the tooth ROS will touch the rung. For since the distance of the curve RO from the epicycloid CP is by construction equal to the radius of the rung EX ; if that radius be taken from the straight line AE , which is perpendicular to the epicycloid (539), the point X will be necessarily in the curve RO , parallel to the epicycloid; the cylinder E and the curve RO will therefore touch each other in the point X , where the straight line AE meets with the circumference of the rung.

As the engagement might be rendered too weak, were no more than the length here determined given to the teeth, it will be proper to give to the true radius of the wheel a mean length between OF and XF , and to cut off the point of the tooth, as seen fig. 185.

The teeth of the wheel being constructed in this manner, it is evident that they will not move the rungs till their centres have reached the line of centres; and that the rungs, on the other hand, will move these teeth by impelling them towards the line of centres GF , and until their centres have reached that line.

If the primitive radius of the wheel be taken from the true radius chosen, the remainder will

be the quantity of the engagement of the teeth of the wheel in the primitive lantern ; and as the semi-diameter of each rung will necessarily enter the primitive wheel, the whole quantity of the engagement will be equal to the sum of the semi-diameter of the rung, and of the excess of the true radius of the wheel above its primitive radius.

The distance FG of the centres of the wheel and of the lantern being given, it will be easy to determine by calculation the length of the shortest true radius of the wheel, when the number of the rungs of the lantern and the number of the teeth of the wheel are given.

EXAMPLE.

Let us suppose that the wheel ought to have thirty teeth ; that the lantern has eight rungs, and that FG, the distance of the centre of the wheel from the centre of the lantern, is three feet, or thirty-six inches.

First find the primitive radius of the wheel by this proportion :

$$\text{As } 38 : 30 :: 36 \text{ inches to a fourth term } \frac{30 \times 36}{38}$$

which will be the primitive radius AF of the wheel. When the calculation is finished, the primitive radius AF will be found = 28.421 inches. If this primitive radius of the wheel be taken from FG = 36 inches, the remainder 7.579 inches will be the primitive radius AG of the lantern.

As the lantern has eight rungs, the chord AE, drawn through the centres of two neighbouring

rungs will be the chord of 45 degrees ; consequently will be double the sine of 22° 30'. Hence, to find AE we must employ the following proportion :

As radius 100000
Is to double the sine of 22° 30' . . . 0·76537
So is the primitive radius of the lantern
7·579 inches.

To the chord AE, which will be found equal to 5·800 inches,

As the wheel has thirty teeth, the arc AC, which comprehends in the primitive circle of the wheel one tooth, and the space which separates two teeth, will be equal to twelve degrees, the fourth part of which is three degrees. When it is required, therefore, to make the breadth of each tooth equal to the space which separates them, the two arcs DR and DS must each be made equal to three degrees.

Let us suppose that the play AL of the engagement ought to be one degree : the foot of the tooth CPL, terminated by two epicycloids CEP and LP will be eleven degrees, and its half DC or DL will be 5° 30' ; from which we must take DR or DS, which will be three degrees, and there will remain 2° 30' for each of the two arcs CR and LS, which must be taken from the foot of the tooth CPL to correct it. The chord of the arc CR or LS will, therefore, be double the sine of 1° 15'. Hence, to find the length of that chord, the following proportion must be employed.

As radius - - - 100000
Is to double the sine of 1° 15' - 0·04363

So is the primitive radius AF already found 28·421 inches

To the chord of the arc CR or LS.

The calculation being made, it will be found that the chord of the arc CR is 1·24 inch.

As the radius EX of each rung ought to be equal to the chord of the arc CR, we shall have also EX = 1·24 inch.

Hence the diameters of the rungs of the lanterns will be 2·48 inches; and since AE has been found = 5·800 inches and EX = 1·240 inch, we shall have AX = 4·56 inches.

To determine the least true radius that the wheel can have, it must be observed, that in the triangle XAF there are known the side AX, which has been found to be 4·56 inches; the side AF which has been found to be 28·421 inches, and the angle XAF, which being the supplement of the angle EAK = 67° 30', will be 112° 30'. The length of the true radius XF may therefore be determined by plane trigonometry, as follows:

<i>As the sum of the two sides AX and AF</i>	32·981
<i>Is to their difference</i>	- 23·861
<i>So is the tangent of half the angle EAK,</i>	
<i>or 33° 45', which is</i>	- 0·66818

To the tangent of half the difference of the two angles AXF and AFX.

When the calculation is finished, this tangent will be found to be 0·48341, which corresponds to an angle of 25° 48'.

This angle 25° 48' added to 33° 45'; which is

half the sum of the two angles AXF and AFX, the sum $59^{\circ} 33'$ will be equal to the angle AXF.

The angle AXF being found to be $59^{\circ} 33'$, and the angle XAF being given, or known to be, = $112^{\circ} 30'$, the supplement of which is $67^{\circ} 30'$; AF also being found to be 28.421 inches, we must use this proportion :

*As the sine of the angle AXF, $59^{\circ} 33'$ 0.86207
Is to the sine of the angle XAF or EAK,
 $67^{\circ} 30'$ - - - - - 0.92388*

So is AF 28.421 inches

To XF, the least true radius which the wheel can have, and which will be found to be 30.458 inches.

Hence if we suppose that FG, the distance of the centres of a wheel of thirty teeth, and a lantern of eight rungs, is thirty-six inches; that the play of the engagement ought to be one degree, and the breadth of each tooth ought to be equal to the space between every two teeth, we shall find ;

	Inches.
The primitive radius of the wheel -	28.421
That of the lantern - - -	7.579
The least true radius of the wheel -	30.458
The quantity of the engagement of the wheel in the primitive lantern - -	2.037
The semi-diameter of the rung, or the quantity of the engagement of the lantern in the primitive wheel - - -	1.24
The total quantity of the engagement	3.277
The true radius of the lantern -	8.819
<i>Had the diameters of the rungs of the lantern been</i>	

given, less calculation would have been required to determine the true radius of the wheel; for, having found AE, and taken from it the radius EX, of the rung, the calculation might have been finished as above explained.

Remark.

547. The form of the teeth of a wheel being determined as above, cut away the rim of the wheel to leave spaces between the teeth (fig. 185), and direct the sides of the spaces between the teeth TZ and S& towards the centre F of the wheel. These spaces serve for lodging the rungs, which ought to be met only by the teeth that move them, otherwise the machine would be liable to shocks, which would fetter its motion, and which, if considerable, might prevent it from going.

It has been seen (542), and will be seen also in the following problem, that the sides TZ and S& of the spaces sunk into the primitive wheel, being directed towards the centre F of the wheel, the part of the rung which goes beyond the primitive circle of the lantern, ought to have the form of an epicycloid, having for its base the primitive circle of the lantern, and generated by a circle of a diameter equal to the radius AF of the wheel. Hence, a cylindrical rung does not seem proper for being carried towards the line of centres by the side TZ of the space sunk into the primitive wheel. But the preceding rung E being moved by the preceding tooth of the wheel, until the centre of the rung A has reached the line of centres, and the space TA,

which the straight line TZ ought to make the rung pass over, before it reaches the line of centres, being very short; the arc of the rung, on which the side TZ will glide in impelling this rung, will be so small, that it may be considered as the small arc of an epicycloid; consequently, if there be any inequality in the movement of the lantern by the wheel, while the part TZ of the tooth moves the rung, this inequality will be so small as not to be sensible.

When the lantern has not too small a number of rungs, and the diameter of the rungs is not too great, this small inequality may be obviated. The preceding rung E may be made to move by the tooth RX \times S (fig. 186), until the straight line TZ has arrived at the line of centres. For the straight line TZ will not then be obliged to move the rung A, and the curved part only of the tooth TV will have to move it: as this curved part of the tooth has the form proper for moving the rung by removing it from the line of centres, the lantern will be driven by the wheel without any inequality.

But, in causing the rung E to be moved by the tooth RX \times S, until the straight part TZ of the following tooth has arrived at the line of centres, the length just determined for the least true radius of the wheel will be too small, and it will be necessary to search for a true radius of greater length.

Let us suppose, as already done, that the wheel is to have thirty teeth; that the lantern has eight rungs, and that the distance FG of the centres of the wheel and lantern is thirty-six inches. Let us

suppose also, to facilitate the calculation, that the rungs are two inches in diameter, or of one inch radius, and that the play of the wheel in the engagement is one degree.

The primitive radius FT of the wheel
will be (546) - - - (inches) 28·421

And that GA or GT of the lantern 7·579

If from A, the centre of the rung, there be drawn AB perpendicular to the straight line FG, which touches this rung, and which joins the centres of the wheel and lantern, this perpendicular will be the radius of the rung. Hence, if the square of the radius of this rung, or the square of one inch, be taken from the square of the radius AG of the lantern; that is to say, the square of 7·579 inches, which is 57·441241 square inches, the square root of the remainder 7·513 inches will be the value of GB; and as FG has been supposed = 36 inches, we shall have FB = 28·487 inches.

The side FB = 28·487 inches of the right angled triangle ABF being considered as radius, the side AB = 1 inch, as tangent of the angle AFB, this angle will be found to be $2^{\circ} 0\frac{1}{4}'$; consequently the angle BF *b*, comprehending the rung A, will be $4^{\circ} 1\frac{1}{4}'$.

The side GB = 7·513 inches of the right angled triangle ABG, being also taken as radius, and the side AB = 1 inch being considered as the tangent of the angle AGB, this angle or the arc TA will be found to be $7^{\circ} 35'$.

As the lantern has eight rungs equally distant from each other, the arc AE, comprehended between

the centres of two neighbouring rungs will be 45° ; hence the sum of the two arcs TA and AE, or the arc TAE will be $52^\circ 35'$, and its chord TE will be found to be = 6.714 inches.

Lastly, if one inch be taken from this chord for the radius EX of the rung, we shall have TX = 5.714 inches.

The arc TAE having been found to be $52^\circ 35'$, we shall have the sum of the two angles TFX and TFX, or the angle ETG = $63^\circ 42\frac{1}{2}'$.

In the triangle XTF, the two sides TX and TF, with the sum of the two angles TFX and TFX, opposite to these two sides being known, the angle TFX will be found to be $9^\circ 24'$, and the side XF 31.374 inches. Hence the length of the least true radius XF, which the wheel can have to move the lantern uniformly will be determined.

The tooth RX & S having begun to move the rung E, when its straight part BY was in TZ, on the line of centres, and not having ceased to impel it till the straight part TZ of the next tooth had reached the same line of centres, the arc TR of the primitive wheel comprehends a tooth and a space; and as this wheel has thirty teeth and thirty spaces, the arc TR contains the thirtieth part of the circumference, that is to say, twelve degrees.

But the angle TFX has been found to be $9^\circ 24'$

Hence the angle RFX, or the arc RD
will be - - - - - $2^\circ 36'$

The angle BF b or TF b which comprehends the rung being - - - - - $4^\circ 1\frac{1}{4}'$

And the angle b FS of the play intended

to be given to the wheel in the engagement,
being - - - - - 1°

The angle BFS, or the arc TS will be $5^\circ 1\frac{1}{4}$

And as the arc TR is - - - - - 12°

The tooth RX *x* S will occupy on the
circumference of the primitive wheel, an

arc RS = - - - - - $6^\circ 58\frac{3}{4}$

But the arc RS, which will be the foot of the
tooth RX *x* S being greater than the double of the
arc RD, which corresponds to the curve RX, over
which the rung E is driven, that tooth may be en-
closed between two equal curves RX and S *x*, simi-
lar and similarly situated in regard to it, and ter-
minated by an arc X *x* concentric to the wheel.

The two curves RX and S *x*, which form the
sides of the tooth being equal, similar and similarly
situated in regard to it, the two angles RFX and
SF *x* will be equal; consequently each of them will
be $2^\circ 36'$. If we, therefore, deduct the sum $5^\circ 12'$
of these two angles from the angle RFS, or the arc
RS, which has been found to be $6^\circ 58\frac{3}{4}$, the re-
mainder $1^\circ 46\frac{3}{4}$ will be the measure of the angle
XF *x*, or of the arc X *x*, concentric to the wheel, by
which the tooth RX *x* S will be terminated.

It results from this remark, that if a wheel of
thirty teeth is to move uniformly a lantern of eight
rungs, impelling these rungs only after they have
passed the line of centres, if the play of the wheel
in the engagement be one degree, and if the dis-
tance FG of the centres of the wheel and the lan-
tern be thirty-six inches, the radius of each rung
being an inch,

The primitive radius—		
	Inches.	
Of the wheel will be	-	28·421
Of the lantern	- -	7·579
The true radius—		
Of the wheel will be	-	31·374
Of the lantern	- -	8·079
The angle RFS, including one tooth of the wheel will be	- -	6° 58 $\frac{3}{4}$
The arc Xx, drawn concentrically to the wheel to terminate the tooth, will be	-	1° 46 $\frac{3}{4}$

Problem.

548. *The number of the teeth of a wheel, and the number of the wings or leaves of the pinion into which it is to act, with the distance FB (fig. 171), of their centres being known, to find their primitive and their true radii; and to determine the form of the teeth of that wheel, and the form of the leaves of the pinion.*

Solution.

1st. Having divided the distance FB of the centres into two parts AF and AB, proportional to the number of the teeth of the wheel, and to the number of the leaves of the pinion, these two parts AF and AB, will be the primitive radii of the wheel and the pinion; and if with these two parts as radii there be described, from the points F and B as centres, two circumferences R and X, these circumferences, which will touch in the point A, will be those of the primitive wheel and pinion. Hence

the radii and the primitive circles of the wheel and pinion will be determined. Q. E. F.

2nd. A wheel is generally cut in such a manner that the breadth of the teeth is equal to that of the spaces. In this case, the primitive circumference R of the wheel is divided into twice as many equal parts as it ought to have teeth, in order to determine the feet CA , LQ , &c. of these teeth, and the spaces AL , GQ , &c., which ought to be between them. But, if it be required that the teeth should occupy more width than the spaces, as is proper in certain circumstances, and as will be seen in the scholium of this problem, the primitive circumference must first be divided into as many equal parts, CL , LG , &c. as it ought to have teeth; and each part, such as CL , must afterwards be divided into two other parts, CA and AL , one of them equal to the breadth intended to be given to each tooth, and the other to the space intended to be made between two teeth. The feet CA and LQ , &c. of all the teeth being determined on the primitive circumference of the wheel, straight lines Cc , Aa , Ll , Qq , &c. nearly equal to the breadths CA and LQ of these feet must be drawn through their extremities, towards the centre of the wheel, to mark out the straight sides of the teeth; and through the extremities of each foot, such as CA , there must be drawn two equal epicycloids, CP and AP , the generating circle of which Y has for diameter the radius AB of the pinion, and which both have for base the primitive circumference of the wheel. These epicycloids, when traced out,

will contain those parts of the teeth which project beyond the primitive circle of the wheel; so that the straight line FP , drawn from the centre of the wheel to the point P , where the two epicycloids of one tooth meet, will be the greatest true radius which the wheel can have in regard to the breadth given to the teeth and to the spaces made between them. The form of the teeth of the wheel and its greatest radius will, therefore, be determined. Q. E. F.

3d. Having divided the primitive circumference X of the pinion into as many equal parts OH , HS , ST , TZ , and ZO , as it ought to have leaves, each part, such as OH , must still be divided into two other parts Oo , oH , one equal to the thickness intended to be given to the leaf, and the other to the breadth of the space which ought to be left between two leaves; observing that the breadth oH of the space must be a little greater than that of AC the tooth of the wheel, in order that the tooth may enter it, and that there may be proper play in the engagement. The breadths Oo , Hh , &c. of all the leaves of the pinion being thus determined on the primitive circumference of the pinion, straight lines a little longer than the projection Pp of the teeth of the wheel beyond their primitive circle must be drawn through their extremities, towards the centre B of the pinion; and these will determine the spaces into which the teeth of the wheel will act with the proper play. Then through the extremities of the straight sides of each leaf describe two epicycloids, such as Om and om , the

generating circle of which V has for diameter the radius AF of the wheel, and which both have for base the primitive circumference of the pinion. These epicycloids being traced out will contain between them the parts of the leaves which project beyond the primitive circle of the pinion, so that the straight line Bm , drawn from the centre of the pinion to the point m , where the two epicycloids of the same leaf meet, will be the greatest true radius that the pinion can have, in regard to the thickness of its leaves. The form of the leaves of the pinion and the length of its greatest radius will therefore be found. Q. E. F.

Demonstration.

It has been seen (542) that if the radius BH of the primitive circumference of the pinion be impelled by an epicycloid CE , projecting beyond the primitive circle R of the wheel, and generated by the revolution of the circle Y on the primitive circumference of the wheel, the pinion will turn in the same manner: that is to say, with the same force and the same velocity as the wheel, as if the primitive circumference of the pinion were moved by that of the wheel in consequence of their contact, or of an engagement infinitely small. It has been seen also, (548) that if the epicycloid OMm , projecting beyond the primitive circle of the pinion, and described during the revolution of the circle V , on the primitive circumference of the pinion is impelled towards the line of centres by the radius LF of the wheel, the primitive circumferences of the

wheel and pinion will turn with the same force and velocity. In the last place, it has been demonstrated that the two opposite sides of the tooth $cCPAa$, and those of the leaves of the pinion ought to have the same form, to facilitate their action in each other, and to give the wheelwork the power of being moved in contrary directions. But, setting out from these principles, it is evident that the forms given to the teeth of the wheel and to the leaves of the pinion, in the solution of the problem, are proper for causing the pinion to be moved by the wheel or the wheel by the pinion with perfect regularity : and as the forms of the teeth of the wheel and of the leaves of the pinion necessarily determine their true radii, the problem is solved.

Q. E. D.

Scholium.

549. As the curved part of the tooth of the wheel (fig. 169) must press against the straight flank HK of the leaf of the pinion, in removing from the line of centres; and as the point E, where that flank will be met by a perpendicular AE, drawn to it from the point A, will always be that by which the tooth will exercise its impulsive force; it is evident, that the tooth CPG will cease to move the leaf HK, when the extremity P of that tooth touches that leaf at the point E, where it will be met by a right line AE drawn perpendicular to it from the point A: therefore, if the extremity P of the tooth arrive at the point E, before the straight side ON of the following leaf has reached the line of centres, the

curved part OMm of that leaf will be necessarily impelled by the straight side Ll of the following tooth; so that the wheel will move the pinion by impelling its leaves sometimes before, and sometimes behind the line of centres.

But if the extremity P of the tooth CPG (fig. 189, 191, 193) does not reach the point E , and does not cease to impel the straight side HK of the leaf, until the side AN of the following leaf has arrived at the line of centres, or has passed that line, it will not be necessary that the curved parts of the leaves should be impelled by the straight sides of the teeth of the wheel. Hence, the wheel may move the pinion by impelling its leaves only behind the line of centres.

As the tooth rubs against the leaf on entering into the pinion, when it pushes before the line of centres, and on the other hand as it rubs against the leaf in retiring from the pinion when it pushes behind the line of centres, and as the friction which takes place on its entering is greater than that which takes place on its retiring, because in the first case there may be shocks, chiefly when the parts which rub are not very hard and well polished; all mechanists allow that it is much more advantageous to cause the leaves of the pinions to push behind the line of centres, than to cause them to push sometimes before and sometimes behind that line; and if it should be absolutely necessary that the teeth of the wheel should catch the leaves before the line of centres, they must be made to catch as near to that line as possible.

The advantage which pinions of a certain number of leaves have, that they can be moved by the wheels pushing them only behind the line of centres, while those which have fewer cannot be moved uniformly but by making them push their leaves partly before and partly behind the line of centres, renders it necessary to make some observations in regard to the different numbers of their leaves.

I.

For Pinions of Seven Leaves.

550. *A wheel with fifty teeth cannot move in a uniform manner, a pinion of seven, impelling its leaves behind the line of centres.*

In order that the leaves of a pinion of seven may be impelled only behind the line of centres (fig. 187) the tooth CEG must not quit the leaf HB, until the following leaf AB has reached the line of centres, that it may be moved in its turn behind that line; and as in a pinion of seven leaves, the angle ABH, comprehended between the two sides by which two neighbouring leaves may be impelled on the same side, is $51^{\circ} 25' 43''$ nearly; when the tooth CEG quits the leaf HB, the angle FBH will also be $51^{\circ} 25' 43''$ nearly.

If we suppose that the primitive radius AB of the pinion of seven leaves is seven parts, and solve the triangle ABE, right angled at E (549), BE will be found to be 4.364 parts.

The primitive radius AB of the pinion of seven leaves being supposed to be seven parts, and the wheel having fifty teeth, its primitive radius AF

will be fifty parts ; consequently the distance BF of the centres of the pinion and wheel will be fifty-seven parts. Hence we shall have given, in the triangle EBF, the two sides BE and BF, with the included angle EBF, and solving the triangle, the angle EFB will be found to be $3^{\circ} 35' 50''$ nearly.

The wheel being supposed to have fifty teeth, the angle BFC or AFC, which ought to comprehend one tooth and its space, will be $7^{\circ} 12'$; and if from this angle we deduct the angle EFB, which was found to be $3^{\circ} 35' 50''$, there will remain $3^{\circ} 36' 10''$ for the angle CFE.

As the two epicycloids CE and GE, by which one tooth is terminated, must be equal, similar and similarly placed, in regard to the true radius FE, and as the angle CFE has been found to be $3^{\circ} 36' 10''$, the angle CFG, which ought to contain one tooth, will be $7^{\circ} 12' 20''$; consequently it will be $20''$ greater than the angle AFC, which ought to contain one tooth and its space ; but this is impossible, since a part cannot be greater than the whole. It is therefore impossible also that a wheel of fifty teeth, should move, in a uniform manner, a pinion of seven leaves, impelling them merely behind the line of centres.

As a wheel of fifty teeth cannot move uniformly a pinion of seven leaves, impelling them merely behind the line of centres ; a wheel with fewer than fifty teeth will be still less proper for that purpose ; and though in a wheel which has more than fifty teeth, the angle found for one tooth might be less than that which ought to comprehend a tooth and

a space, that for the space, which ought to be made between the feet of two neighbouring teeth, would be so small that it would not be sufficient to receive the leaf of the pinion, unless it were made exceedingly thin; and even in case it were made ever so thin, there would not be sufficient room between the teeth for the play of the engagement. We may, therefore, conclude that a wheel of any number of teeth whatever, is not proper to move a pinion of seven leaves, impelling its leaves only behind the line of centres; therefore, when a pinion of seven leaves is to be moved by a wheel, the leaves must be impelled by the teeth of the wheel partly before and partly behind the line of centres, as seen fig. 188.

II.

For Pinions of Eight Leaves.

551. *A wheel of fifty-seven teeth (fig. 189), and even one of a greater number, is not proper for moving uniformly a pinion of eight leaves, impelling these leaves merely behind the line of centres.*

In order that the leaves of a pinion of eight may be impelled only behind the line of centres, the tooth CEG must not quit the leaf HK, until the straight side AN of the following leaf be in the line of centres; and as a space and a tooth must occupy an angle of forty-five degrees in a pinion of eight leaves, the angle of FBH or FBE will be forty-five degrees. If the primitive radius AB of the pinion be supposed therefore to be eight parts,

the side BE of the right angled isosceles triangle ABE, will be found to be 5·657 parts.

If the wheel be supposed to have fifty-seven teeth, its primitive radius AF will be fifty-seven parts, and BF will be sixty-five parts. In the triangle EBF we shall therefore have given the two sides, BE and BF, with the contained angle EBF, to determine the angle EFB or EFA, which will be found to be $3^{\circ} 45' 7''$.

The angle BFC, which contains one tooth and a space, being $6^{\circ} 18' 57''$ nearly, because the wheel is supposed to have fifty-seven teeth, the angle CFE will be $2^{\circ} 33' 50''$; and as the two epicycloids which contain the tooth CEG will be equal, the angle CFG, comprehending that tooth, will be $5^{\circ} 7' 40''$; consequently the angle AFG of the space between the bases of two neighbouring teeth will be only $1^{\circ} 11' 17''$.

But as the angle AFG of this space is not sufficiently great to receive a leaf of a reasonable thickness, with a play proper for a good action, it ought to be concluded, that a wheel of fifty-seven teeth is not proper for moving a pinion of eight leaves, impelling the flanks of these leaves merely behind the line of centres: and as a wheel of a greater number of teeth would not have a greater space between its teeth, as might easily be proved by a calculation similar to that already made, it would not be more proper for moving a pinion of eight leaves, impelling these leaves only behind the line of centres.

Therefore, when a pinion of eight leaves is to be moved uniformly by a wheel of any number of teeth whatever, its leaves must be impelled by the teeth of the wheel, partly before and partly behind the line of centres, as seen fig. 190.

III.

For Pinions of Nine Leaves.

552. *If a pinion of nine leaves (fig. 191) is to be moved uniformly by a wheel of sixty-four teeth, or by a wheel of a greater number, impelling these leaves merely behind the line of centres, the leaves would be somewhat too weak.*

At the moment when the tooth CEG ceases to move the leaf HK, and the side AN of the following leaf is in the line of centres, the angle HBF will be forty degrees. Therefore, if we suppose the primitive radius of the pinion of nine leaves to be nine parts, and solve the right angled triangle ABE, BE will be found to be 6.8944 parts.

If the wheel be supposed to have sixty-four teeth, its primitive radius AF will be sixty-four parts, and the distance BF of the centres will be seventy-three parts. In the triangle EBF, therefore, we shall have given the two sides BE and BF, with the included angle, and solving the triangle, the angle BFE or AFE will be found to be $3^{\circ} 44' 39''$.

As the wheel has sixty-four teeth and sixty-four spaces, the angle AFC, containing one tooth and a space, will be $5^{\circ} 37' 30''$; and if we take from it the angle AFE, which has been found to be $3^{\circ} 44' 39''$, there will remain $1^{\circ} 52' 51''$ for the value of the

angle CFE, consequently the angle CFG will be $3^{\circ} 45' 42''$.

In the last place, if we take from the angle AFC the angle CFG, there will remain $1^{\circ} 51' 48''$ for the angle AFG of the space between the two teeth of the wheel. But as this angle is not greater than the half of CFG, which contains one tooth; and as the play of the engagement ought to be taken from that angle AFG, there would remain too little of it for lodging the leaf of the pinion: the leaves of the pinion, therefore, would be too weak.

As a wheel of a greater number of teeth made to move a pinion of nine leaves, impelling those leaves merely behind the line of centres, would not have between its teeth spaces sensibly greater than those found for a wheel of sixty-four teeth, there is reason to conclude that a pinion of nine leaves, in order to be moved uniformly, requires to be impelled partly before, and, for the most part, behind the line of centres, fig. 192.

IV.

For Pinions of Ten Leaves.

553. *A pinion of ten leaves may be moved uniformly (fig. 193) by a wheel of seventy-two teeth, impelling the sides of these leaves merely behind the line of centres, provided the space of the pinion be a little more than the thickness of the leaf.*

When the tooth CEG quits the leaf HK, and the side AN of the following leaf is in the line of centres, the angle HBF will be thirty-six degrees; but if we suppose the primitive radius AB of the

pinion of ten leaves to be ten parts, BE will be found to be 8·0902.

As the wheel is supposed to have seventy-two teeth, its primitive radius AF will be seventy-two parts; and the distance BF of the centres will be eighty-two parts. In the triangle EBF, therefore, we shall have given the two sides BF and BE, with the included angle to determine the angle BFE, which will be found to be $3^{\circ} 36' 22''$.

As the wheel has seventy-two teeth and seventy-two spaces, the angle BFC, containing a tooth and a space, will be five degrees; hence the angle CFE will be $1^{\circ} 23' 38''$; consequently the angle CFG will be $2^{\circ} 47' 16''$.

In the last place, if the angle CFG be taken from the angle BFC, there will remain $2^{\circ} 12' 44''$ for the angle AFG of the space between two teeth; and as this angle is almost equal to CFG, which comprehends one tooth, it is sufficiently large to receive a reasonably thick leaf, and to admit of sufficient play. A wheel, therefore, of seventy-two teeth can move uniformly a pinion of ten leaves, impelling the sides of its leaves behind the line of centres only; provided that the space of the pinion be a little greater than the thickness of the leaf.

It is, however, to be remarked, that as a wheel of seventy-two teeth must have a little more width for the teeth than for the spaces, in order to move a pinion of ten leaves, if a wheel of the same number of teeth were made with as much width for the spaces as for the teeth as is customary, the leaves of a pinion of ten, in which this wheel would act,

must necessarily require to be caught by the teeth of this wheel a little before the line of centres, as seen fig. 194.

Remarks.

554. In all the wheels (fig. 187, 189, 191, and 193), the engagement of which with pinions of seven, eight, nine, and ten leaves has been examined, the straight line FE, drawn from the centre of the wheel to the point E, where the tooth quits the leaf of the pinion, divides the tooth of the wheel into two parts, equal and similar. Hence the teeth of these wheels are pointed: but the case cannot be otherwise in wheel-work of this kind, when it is required that the pinion should be moved uniformly, and that its leaves should be impelled behind the line of centres.

If the pinion had a greater number of leaves as eleven or twelve, the tooth might be traced out at first a little longer than necessary, to drive the leaf HK beyond the line of centres, until the side AN of the following leaf has reached that line. The whole quantity of the tooth exceeding the length necessary to move the pinion, as already mentioned, might then be cut off; or this tooth might be terminated by an arc of a circle, touching the two epicycloids of the tooth, as will be explained for the teeth of wheels, which are to move pinions by impelling their leaves partly before and partly behind the line of centres.

When the leaves of a pinion can be impelled only behind the line of centres, it is to be remarked, that

its leaves have no need of being prolonged beyond its primitive circumference; and that the true diameter may be equal to the primitive. But as the angles by which the sides of the leaves would be terminated might scrape against the teeth of the wheels, and occasion stoppages in the machine, it is necessary to keep the true diameter of the pinion greater than its primitive diameter, by a quantity nearly equal to the thickness of the leaves; and to round the extremities of the leaves into half cylinders, so that if any tooth should catch the leaf before the line of centres, it might glide over the roundness of that leaf.

555. In the case where the leaves of the pinion are too small in number (fig. 171) to be impelled merely behind the line of centres, when all the epicycloids which contain the teeth of the wheel, and all those which terminate the leaves of the pinion have been traced out, all the teeth of the wheel must first be slightly blunted, making them to terminate as the tooth CPA, either by a small arc Ee, concentric to the wheel, or by an arc touching the two opposite epicycloids of the tooth, in two points E and e, very near the extremity.

Each tooth, such as CPA, of the wheel being thus blunted, draw at the extremity E of one of its epicycloids a perpendicular EA, meeting the primitive circumference of that wheel in some point A, which may be different from the foot of the other epicycloid. Then having placed that point A in the line of centres, and drawn a perpendicular AM to the side Ll of the following tooth, each leaf,

such as $O m o$ of the pinion, may be blunted by an arc $M n$, concentric with the pinion, or by any other arc touching the two epicycloids of that leaf in the two points M, n . But by thus blunting the leaves of the pinion, the straight line BM is the least true radius that can be given to the pinion.

Advertisement.

556. Though the rules here explained for forming the teeth of wheels, whether they move lanterns or pinions, and those given for the rungs of lanterns, and for tracing out the leaves of pinions, cannot easily be put in practice but in cases where the teeth are to be of the same size, or greater than those represented in the annexed figures, they will not be useless to mechanists who have to form teeth much finer, because, when they have before their eyes the figure of a large tooth, similar to those which they are to execute on a small scale, it will be easy for them to imitate it by the eye.

As they cannot hope to form the teeth with all the equality and precision necessary to make the primitive circumferences of the wheel and of the pinion or the lantern, to turn with the same force and velocity; as inequality and other defects in the teeth might prevent some teeth from impelling to the necessary distance behind the line of centres the leaves or rungs which they ought to move; and as the consequence might be shocks of the leaves or rungs against the sides of the teeth, which would catch these leaves or rungs too soon before the line of centres, mechanists may prevent

this inconvenience by making the primitive diameter of the wheel a little larger than it ought to be, in regard to that of the lantern or pinion.

By means of this enlargement of the diameter of the wheel, which ought to be proportioned to the faults that may be apprehended in the teeth, the tooth which follows that which impels the rung or leaf behind the line of centres, catches a little later the rung or leaf which follows; and when the preceding tooth has impelled the rung or leaf behind the line of centres, as far as it can do uniformly, the wheel acquires a little more velocity than it communicates to the lantern or pinion, which is a defect; but this error into which one voluntarily falls, is less to be apprehended than the shocks to which we should be exposed in attempting to avoid it.

It is evident, that what has been said on the enlargement of the diameter of the wheel beyond what is necessary for moving uniformly the lantern or pinion, supposes the lantern or pinion to be driven by the wheel; but when the wheel is moved by a pinion, it is evident, that to avoid shocks it is the primitive diameter of the pinion that must be made a little larger than necessary to move the wheel uniformly.

As the teeth of a wheel ought to impel the rungs of a lantern by removing them from the line of centres, and as no shocks are to be apprehended, in this method of moving a lantern, one may, without any inconvenience, cause a lantern to be moved by a wheel. But as the rungs of a lantern ought, on the other hand, to impel the teeth of a wheel by

bringing them near to the line of centres; and as shocks may take place in this method of driving a wheel, there is reason to conclude, that when a wheel is to be driven, a pinion is preferable to a lantern.

Hitherto, the object has been only flat wheels, the axes of which are always parallel to those of the lanterns or pinions in which they act. We shall now speak of crown wheels, called commonly bevelled wheels, the axes of which are usually perpendicular, and may be more or less inclined to those of their lanterns or their pinions; and we shall shew that the lanterns and pinions in which wheels of this kind act ought to be conical.*

Definitions.

557. Let there be a right cone CAPBQT (fig. 195), the apex of which C remains immoveable. If the base APBQT of this cone be made to revolve on a plane RES, placed in any manner in regard to the point C, and if we suppose a style or tracer situated in the point A of the circumference of the revolving circle, this style A will describe, during its motion, a curve AMGF, which is called a *spherical epicycloid*.

The style A, affixed at the circumference of the base of the cone, being always at the same distance from the fixed point C, where the apex of the cone remains, all the points of the curve AMGF, traced out by the style A, will be equally distant from the same point C, consequently will be on the surface

* In French *Roues de Chan*.

of a sphere, which will have the point C for its centre. Hence the curve $AMGF$ may be called spherical; and as it is of the epicycloidal kind, because it is formed by the revolution of a circle $APBQT$ on the circumference of another circle RES , it may be called a spherical epicycloid.

The circle $APBQT$, which in revolving describes the spherical epicycloid, is called the *generating circle* of that curve; and the part RES of the circumference, on which it rolls, is called the base of that epicycloid.

If the point C , to which the apex of the cone is affixed, be in the centre of the circle RES , on which its base is made to roll, the whole convex surface of the cone will roll on the plane of that circle. But if the apex C of the cone is not in the plane RES , the convex surface of the cone CA $PBQT$ will always rest on the convex or concave surface of another right cone $CRAEFS$, according as the point C is above or below the circle on which the base of the moveable cone is made to roll; and as the plane of a circle may be taken for a cone infinitely obtuse, it may be said that a spherical epicycloid $AMGF$ is generated by a style A affixed to the convex surface of a right cone, the apex of which C is affixed to that of another right cone, and which rolls on the curved surface of the second cone. Thus, while the point A , common to the convex surface and base of the rolling cone (fig. 196), traces out an epicycloid $AMGF$, any other point a of the convex surface of the same cone, will trace out another spherical epicycloid

amgf on the surface of a sphere, which will have *aC* for its radius; so that any part whatever *Aa* of a side *AC* of the rolling cone will generate the convex surface of a sort of truncated cone, terminated by two epicycloids, *AMGF*, *amgf*, parallel and similar.

Corollary I.

558. As the base *APBQT* of the rolling cone (fig. 195) applies in succession all the parts of its circumference to those of the base *AEF*, this base *AEF* must necessarily be of the same length as the circumference of the circle *APBQT*; and each portion, such as *AD* or *AE* of the same base, must be equal to each part *DM* or *ELG* of the circumference which rolls upon it.

Hence, when the sphere on which the spherical epicycloid is to be traced out is given, and the size and position of the rolling cone which is to generate that epicycloid are known, it will be easy to find as many points of that curve as may be required. For if as many circles *MDN*, *GLE*, &c. equal to the base of the rolling cone, as we wish to have points of the epicycloid described, and if on the circumferences, beginning at the points *D*, *E*, &c. where they touch the base, we take arcs *DM*, *ELG*, &c. equal to the arcs *AD*, *AE*, &c. of that base, comprehended between the origin *A* of the epicycloid and the points of contact *D*, *E*, &c.; the points *M*, *G*, &c. will belong to the spherical epicycloid, and the curve made to pass through all these points will be the spherical epicycloid itself.

If it be required to trace out the spherical epicycloid $amgf$ (fig. 196), which must be described by the point a , while the epicycloid AMGF is described by the point A, it will be necessary to take another sphere, having aC for its radius; and after there has been traced out on the surface of this sphere a portion aef of a circle, placed in regard to this sphere, as the first circle AEF is in regard to the first sphere, the arc aef must be taken as the base of the new spherical epicycloid. In the last place, having drawn, in the rolling cone, a diameter at , parallel to the plane of its base, take the circle which has at for its diameter, as the generator of the epicycloid required. The base and generating circle of the epicycloid which is to be described being found, any number of points of the epicycloid may be determined as before described.

Corollary II.

559. If the axis CK of the cone CAPBQT remained immoveable (fig. 196), and if in making the spherical cone CRES turn on its axis, its surface by its contact carried with it that of the cone CAPBQT, it is evident that all the parts of the circumference APBQT would be successively applied to those of the arc AEF; and that the points Aa of the convex surface of that cone would trace out on the surface of the two concentric spheres the two spherical epicycloids AMGF, and $amgf$, the construction of which has been explained; so that the portion Aa of the side of the same cone will generate the convex surface of a kind of truncated

cone, contained between these two similar and parallel epicycloids.

It thence follows, that if, in the portion of a hollow sphere, there be cut a portion of a truncated cone, the convex surface of which is terminated by the two epicycloids $AMGF$ and $amgf$, just constructed; this portion of the epicycloidal truncated cone will move the cone $CAPBQT$, impelling it by the portion Aa of its side, in the same manner as the spherical cone $CRES$ would move it by communicating to it its motion merely by contact, or by an engagement infinitely small.

But the spherical cone $CRES$, in moving the cone $CAPBQT$ by mere contact, will communicate to it all its velocity, and consequently all its force.

The truncated portion then of the epicycloidal cone, impelling by its convex surface the part Aa of the side AC of the cone, will communicate to the surface of that cone all its velocity, and consequently all its force; hence the base $APBQT$ of this cone will turn with the same velocity and the same force as the circle RES of the sphere.

As it is essential to the perfection of wheel-work, that a part which moves another should communicate to it the velocity it has itself, it will be from this corollary chiefly that we shall deduce the best form that can be given to the teeth of a crown wheel, which is destined to move a lantern. A portion $AMma$ (fig. 196) of the convex surface of the epicycloidal truncated cone, cut in the hollow sphere, will represent the side of a tooth of a wheel; and the part Aa ,

of the side AC of the cone, will represent an infinitely small rung of the lantern: and as all the other rungs will be disposed in the same manner as the rung A a, in regard to the axis CK of the cone, all the rungs of the lantern will be distributed on the convex surface of a truncated cone, the apex of which will be in the centre C of the hollow sphere in which the teeth of the wheel are cut.

Problem.

560. The number of the teeth of a crown wheel, and the rungs of a lantern in which it is to act, being given (fig. 196 and 200); also the position of the axis of the lantern in regard to that of the wheel, and the diameter of the circle RES, which is to pass through the commencement of the exterior rotundity of all the teeth, to trace out the teeth of the wheel, and to find the size and form of the lantern.

Solution.

Draw the straight line RS (fig. 197, 198, 199) equal to the diameter of the circle, which is to pass through the commencement of the exterior rotundity of all the teeth of the wheel, and divide it into equal parts by the perpendicular XY, which will represent the axis of the wheel. Having then drawn through the extremity of the line RS a straight line RT, making with RS an angle TRS equal to the angle KCX, which the axis of the lantern ought to form with that of the wheel, make RT of such a length that RS may be to RT, as the number of the teeth of the wheel is to the number

of the rungs of the lantern. This line RT , which in future we shall call the *principal diameter* of the lantern, will be that which the lantern will have at the place where its rungs are met by the exterior faces of the teeth of the wheel.

Having then drawn through the middle of the straight line RT , a perpendicular KC , as far as the axis of the wheel, this perpendicular will be the axis of the lantern, which must be made conical, and the point C , where this axis meets that of the wheel, will be the summit of the lantern; so that the indefinite straight lines, CRG and CTF , drawn through the point C and the extremities of the principal diameter RT , will be the direction of the axes of the rungs of the lantern.

The same point C , where the axis of the lantern meets that of the wheel, will be the centre of a spherical zone or belt, which may be made of any thickness at pleasure, in order to cut in it the teeth of the wheel; therefore, if from the point C , as a centre, and with the radius CR , there be described an arc ARD , one part of which AR is a little greater than the height proper to be given to the teeth of the wheel; and the other RD be equal to the rim of that wheel, without including the teeth, by making this arc ARD revolve around the straight line XY as axis, there will be formed a spherical zone $ADEB$, the upper part of which $ARSB$ will serve to form the exterior faces of the teeth of the wheel, and the lower part $RDES$ will be the rim which will sustain these teeth; so that the circumference of the circle having RS for diameter, will

pass through the origin of the exterior curves of all the teeth.

Having drawn through the extremities of the arc AR the two radii CA and CR; and having taken on one of them a part A *a*, equal to the thickness required to be given to the teeth of the wheel, describe from the point C, as a centre, the arc *a r* between these radii; and making this arc revolve around the axis XY of the wheel, there will be formed a spherical zone *a r s b*, on which must be traced out the interior faces of all the teeth, the curves of which will proceed from the circumference having *r s* for its diameter, and described by the motion of the point *r*.

The two zones, the exterior ARSB and the interior *a r s b*, of the teeth of the wheel being determined, with the size and position of the principal diameter RT of the lantern, draw parallel to that diameter two straight lines FG and HI, the distance of which from each other shall be equal to that intended to be made between the two plates of the lantern, and which may be equally distant nearly from the two zones, the exterior and interior of the teeth. These two straight lines FG and HI, when terminated by the two straight lines CRG and CTF, will represent the diameters of the two circumferences which must be traced out on the two opposite plates of the lantern, through the centres of the rungs, which ought to be conical, and whose summits will meet with that of the lantern in the centre C of the two spherical surfaces of the zone, in which the teeth of the wheel must be cut.

All the dimensions of the lantern being determined, and a part of the spherical belt, in which the teeth are to be made, being formed of plaster or any other matter sufficiently solid, nothing will be necessary but to describe on the opposite surfaces of this belt, the exterior and interior faces of a tooth, in order to have a model for tracing out the rest.

As a description of the curves of the opposite faces of one tooth of the wheel will depend on the size intended to be given to the rungs of the lantern, and as the curvature of the teeth which are to drive conical rungs of a finite diameter, cannot be determined but by corrections made in the form of the teeth proper for moving rungs infinitely small, order requires that the rest of the solution should be divided into two parts. In the first, we shall show how to trace out the teeth of a wheel for rungs infinitely small; and in the second, shall explain the corrections which ought to be made to these first teeth, in order to put them in a state to move uniformly conical rungs, the summits of which meet in the centre C of the spherical belt, in which the teeth are formed.

I.

For the Teeth of a Crown Wheel when the Rungs of the Lantern are infinitely small.

561. It has been demonstrated (559), that if the zone of a hollow sphere (fig. 196) be cut into a truncated form, the convex surface of which AGF fga , is terminated by two spherical epicycloids AM

GF, $a m g f$, generated by two points A, a of the same side of a cone CAPBQT, during the rolling of that cone on the convex surface of another cone CRAEFS, the convex surface of this truncated part in impelling the portion Aa, of the side of the cone CAPBQT, will communicate to the circumference of the base of that cone all the velocity of the circumference of the circle RAEFS; and as the portion Aa of the side of the cone CAPBQT may be taken for a rung infinitely small of a lantern, having the same dimensions as the cone, and as the rung Aa is directed towards the centre C, of the portion of the spherical belt which moves it, there is reason to conclude that the tooth AMN $n m a$ of the wheel, the side of which AM $m a$ is a portion of the convex surface of the epicycloidal truncated part already mentioned, is the most perfect for moving a rung of a lantern infinitely small; and that this rung ought to be directed towards the centre C of the spherical belt, in which the teeth of the wheel are cut. Q. E. F.

As it is in some measure necessary, or at least very useful, that the teeth of the wheel should move the lantern in contrary directions, it is evident that each tooth, such as AMN $n m a$, ought to have the two opposite sides, AM $m a$ NM $m n$, equal, similar and similarly placed; and that this tooth ought to be sufficiently long to move the rung Aa beyond the plane which passes through the axes of the wheel and the lantern, until another rung arrives in the same plane, to be moved in its turn by another tooth of the wheel.

The other remarks which might be made on the figure and length of the teeth, and the method of forming the teeth of a crown-wheel, which is to move a lantern with rungs infinitely small, and on the space which ought to be left between the teeth for the play of the engagement, being similar to those made in section 545 in regard to flat teeth, which move lanterns with rungs of the same kind, it is needless to give here what would be merely a repetition of the same principles.

II.

For the Teeth of a Crown-Wheel which moves a Lantern with conical Rungs of a determinate Diameter.

562. First trace out the teeth of the wheel as if it had to move a lantern with rungs infinitely small (fig. 200), taking care to leave for the play of the engagement, small spaces between the feet of all the teeth.

Having then made a lantern with conical rungs, all the summits of which meet in the centre C of the spherical belt, in which the epicycloidal teeth have been cut, mark, on the exterior surface of that belt, the diameter which one rung has at the place A, corresponding to that surface; and mark, in like manner, on the interior surface of the same belt, the diameter which the same rung has at the point *a*, where it meets that surface.

The diameters which the rungs will have in the opposite surfaces of the dentated spherical belt be-

ing marked out on these surfaces, take, on these surfaces, the chords of half the arcs to which these diameters correspond. These chords, which will not be sensibly longer than the radii of a rung, measured at the places where it is met by the two spherical surfaces of the belt, being taken as radii; describe, on the exterior and interior faces of each tooth, as many small arcs as possible, having their centres in the epicycloids, between which these faces are included. Having then made to pass through these small arcs curves, such as OM, VN, which will necessarily be parallel to the epicycloids first traced out, and which will form the curved parts of the new teeth, proper for moving the conical rungs already mentioned, make, in the rim of the wheel, below the primitive circle RES, indentations, such as VXYZ, terminated by two planes, which will pass through the axis of the wheel and the origin V and Y of the curves parallel to the epicycloids.

The curves OM and VN, and the straight sides OP and VX of each new tooth, being traced out on the exterior and interior surfaces of the spherical belt, cut out the teeth in such a manner, that a straight line fixed by its extremity at the centre C of the dentated belt, being moved along the sides POM, XVN, of the exterior surface of each tooth, may be applied exactly to the lateral surfaces of these teeth, and you will then have a wheel proper for moving the lantern with conical rungs for which it was constructed.

Advertisement.

563. Though fig. 200 represents only spherical epicycloids, containing the exterior faces of the first teeth, proper for moving rungs infinitely small, and as to avoid confusion we have suppressed those which ought to contain the interior faces of the same teeth, we have however traced out all the curves which must be drawn parallel to these epicycloids, to reform the first teeth, and put them in a state to move uniformly a lantern with conical rungs, the summits of which are in the axis of the wheel.

As the small arcs of circles, which ought to have their centres in the spherical epicycloids, and through which the curves parallel to these epicycloids must be drawn, might have occasioned confusion, had they been traced out on the surfaces of all the teeth, they have been described only to reform one exterior side of one tooth marked H.

All the remarks which might be made on the manner of terminating the new teeth, or of blunting their points, and of putting them into such a state as not to impel the rungs till they have passed the plane of the axis of the wheel and of the lantern, in order to avoid friction on entering, being nearly the same as those given, section 546, in regard to flat wheels, it is needless here to repeat them.

Theorem.

564. *While the circumference of the base of a right cone CABT (fig. 201), the axis of which CK*

remains motionless, and whose apex C is in the axis QO of a circle RES, is moved by the circumference of that circle, and (559) a point A of the circumference of the base of that cone describes a spherical epicycloid AGF, on a spherical zone RESXY, which has for radius the side CA of that cone ; if we suppose a second right cone MAPK touching the circumference of the base of the former in the point A, where it is met by that of the circle RES, and which consequently is obliged to turn as well as the first cone ; if the new cone has its apex M in the axis of the circle RES and its axis ML, parallel to that of the first, and if its base APK has for diameter the radius AK of the base of the first cone, a style A affixed to the circumference of the base of the second cone, will pass over the diameter AT of the base of the first, and at the same time describe a spherical epicycloid AIHE, on a second spherical zone RE SVZ, which will have for radius the side MA of this new cone.

Demonstration.

A part of the demonstration of this theorem is the same as that of paragraph 538, and the other part is a consequence of the definition of spherical epicycloids similar to that of paragraph 557.

Corollary I.

565. Since the style A, affixed to the circumference of the circle APK (fig. 201), describes at the same time the diameter AT of the circle ABT, and the spherical epicycloid AIHE, on a zone

RESVZ which has MA for radius, it may readily be conceived that the spherical epicycloid AIHE will continually touch the diameter AT of the circle ABT, while the circumference of this circle will be moved by that of the circle RES, and will turn with the same velocity as it does. Hence it is evident, that instead of making the circumference of the circle ABT to be moved by that of the circle RES, to communicate to it the whole velocity of the latter, we may make a part AL of the diameter AT, to be impelled by a part AI of the spherical epicycloid AIHE.

Corollary II.

566. If the circle RES be considered as the base of a right cone CRES, the convex surface of which touches that of the cone CABT in a straight line CA, and if these two cones be conceived to be cut, parallel to their bases, by the planes *res*, *abt*, drawn through the same point *a*, taken at pleasure, of the line CA, common to their convex surfaces; the circumference of the section *res* will move the cone CABT, by the circumference *abt* of the section, in the same manner as the circumference RES would move it by the circumference of its base ABT.

This being premised, if we suppose, as in the theorem, a right cone *mapk*, the base of which *apk* has for diameter the radius *ak* of the circle *abt* and touches internally the point *a* of the circumference of this circle, so that the new cone moved by the circumference *res* shall be obliged to

roll within the circle abt , a style a fixed in the circumference of the circle apk will traverse the diameter at of the circle abt , and at the same time describe a spherical epicycloid $aihe$, on a spherical zone $resus$, which will have for radius the side ma of this new cone.

Hence the spherical epicycloid $aihe$ will continually touch the diameter at of the circle abt , while its circumference will be moved by that of the circle res ; consequently, instead of causing the circumference of the circle abt to be moved by that of the circle res , to give it all the velocity of the latter, a part al of the diameter at may be made to be impelled by a part ai of the spherical epicycloid $aihe$.

Corollary III.

567. It follows from the last two corollaries, that if there be cut in the portion of a hollow sphere a truncated part $AHE eha$, the convex surface of which is terminated by two spherical epicycloids $AIHE$, $aihe$, of which mention has been made in the theorem, and in the preceding corollary, this truncated part will move the cone $CABT$, impelling it by a plane $AK ka$ drawn through its axis, as it would be moved by the circumference of the circle RES , or that of the circle res , carrying it along by the circumference of its base ABT , or by that of the section abt .

And as the circumference ABT of the base of the cone will acquire all the velocity of the circumference of the circle RES , when it is moved by the

circumference of that circle, or when the section of it abt is moved by that of the circle res , it is evident, that the circumference ABT of the base of that cone, will acquire all the velocity of the circumference RES , when the truncated part comprehended between the two spherical epicycloids $AIHE$, $a i h e$, impels it by a plane $AKka$, passing through its axis CK .

568. *It is from this corollary that we shall deduce the construction of crown-wheels, and of the pinions they are destined to move. A portion $AIia$ of the convex surface of the epicycloidal truncated part, comprehended between the two spherical epicycloids $AIHE$, $a i h e$, will represent the side of a tooth $AINnia$, which can move the leaves of a pinion, after they have arrived in the plane of the axes of the wheel and the pinion; and the trapezium $AKka$ terminated by the axis CK ; and by the side CA of the cone $CABT$ will represent the side of a leaf of the pinion. And as all the other leaves of the pinion will be disposed in the same manner as $AKka$, in regard to the axis CK of the cone, all the leaves of the pinion will be contained in the truncated part of the cone, comprehended between the two circles ABT , abt ; so that the sides and ends of the leaves will be directed towards a point C of the axis of the hollow sphere, in which the teeth of the wheel are cut.*

Problem.

569. *The number of the teeth of a crown-wheel (fig. 202), and that of the leaves of a pinion, which is to be engaged with it, being given, and also the*

position of the axis of the pinion, in regard to that of the wheel, and the diameter of the circle RES, which passes through the origin of the exterior curves of all the teeth, to trace out the teeth of the wheel, and to determine the size and form of the pinion.

Solution.

As in the solution of the preceding problem (560), draw a straight line RES (fig. 203, 204) equal to the diameter of the circle, which is to pass through the origin of the exterior curvature of all the teeth, and divide it into two equal parts by a perpendicular XY, which will represent the axis of the wheel. Having then drawn through the extremity R of that line a straight line RT, making with it the angle TRE, equal to the angle KCX, which the axis of the pinion ought to form with that of the wheel; make RT of such a length, that RS may be to RT as the number of the teeth of the wheel is to the number of the teeth of the pinion which is to be engaged with it; and this straight line, which may be called the *principal diameter of the pinion*, will be that which this pinion will have, without comprehending the rounding of its leaves at the place where it will be met by the exterior faces of the teeth of the wheel.

Having then drawn through the middle of the straight line RT, a perpendicular KC, as far as the axis of the wheel, this perpendicular will be the axis of the pinion which ought to be conical (568); and the point C, where this line meets with the

axis of the wheel, will be the apex of the cone in which the pinion must be cut ; so that the straight lines CRG , CTF , drawn through the extremities of the principal diameter RT , will mark the direction of the ends of the plane sides of the leaves of the pinions.

Having taken, in CR , a part Rr , equal to the thickness which the teeth of the wheel ought to have, at the commencement of their rotundity, draw, in the angle TCR , a straight line rt , parallel to RT , and the trapezia $RKkr$, $TKkt$ will represent the plane sides of the two leaves of the pinion. But as it is advantageous to give to the body of the pinion a greater length than the part through which the leaf may be impelled ought to have ; draw still in the angle TCR , parallel to RT , and at distances nearly equal from the two straight lines RT , rt , two straight lines GF , gf , and take the trapezium $FGgf$, as the profile of the pinion, cut according to its axis, though none but the part of that pinion corresponding to the trapezium $RTtr$ can be met by the teeth of the wheel.

The two straight lines RT , rt , being divided into two equal parts by the axis CK of the pinion, and having drawn to the middle of their halves, KR , kr , perpendiculars LM , lm , which will meet the axis of the wheel in two points M , m , first describe from the point M , as a centre, through the point R , an arc KRD the part of which RK shall be a little longer than the height which, according to supposition, can be given to the curved parts of the teeth of the wheel, and the other part RD equal to the

rim of that wheel, without comprehending the round parts of the teeth ; then cause this arc KRD to turn around the straight line XY as an axis, and there will be formed a spherical zone $KDEB$, the upper part of which $KRSB$, will serve to form the exterior curved faces of the teeth of the wheel ; and the lower part $RDES$ will be the rim which supports the teeth.

Then, from the point m as a centre, with the radius mr , describe another arc krd ; if this arc be made also to turn around the straight line XY as an axis, there will be formed a new spherical zone $kdeb$, on the upper part of which are to be traced out the interior faces of the teeth of the wheel, the curvatures of which must proceed from the circumference of the circle described by the radius re .

The dimensions of the pinion being determined, and the spherical belt, in which the teeth must be cut, being formed of any material sufficiently solid, the problem will then be reduced to this : to trace out on the exterior and interior surfaces of this belt the exterior and interior faces of a tooth, in order to have a model for tracing out all the rest.

To form the side of the exterior face of a tooth, describe on the surface of the zone, represented by its profile $RSBK$, a portion of a spherical epicycloid, having for generating circle the base of the cone, the profile of which is represented by the triangle KMR , and having for base the circumference of the circle described by the point R , in the revolution of the arc KR around the axis XY ; and

to trace out a side of the interior face of the same tooth, describe on the surface of the zone, represented by its profile $rsbk$, a portion of a spherical epicycloid, having for generating circle the base of the cone, the profile of which is the triangle kmr , and for base the circumference of the circle of which rs is the diameter.

The two straight lines Aa, Nn , (fig. 201) directed towards the apex C of the cone of the pinion, being the origin of the curved sides of a tooth, and the two portions AI, ai of the epicycloids, which ought to border one side of the exterior and interior faces of that tooth being traced out, describe two other portions NI, ni of epicycloids, equal and similar to the two former, which they will meet in the points I, i ; and the spaces AIN, ain will be the models on which must be formed the exterior and interior faces of all the teeth of the wheel: the problem therefore will be completely solved.

Advertisement.

570. In this problem we have determined only the curved parts of the teeth of the wheel, by which the plane sides of the leaves of the pinion ought to be impelled, after they have arrived in the plane of the axes of the wheel and pinion; and we have considered the cone of the pinion only in the case where the sides of its leaves are entirely plane, and cannot be impelled but beyond the plane of the axes. But to avoid the shocks which might occur, if the teeth should meet with any of the leaves be-

fore the plane of the axes, it is necessary to make the cone of the pinion a little larger than it has been found.

If the cone of the pinion be enlarged in such a manner, that each diameter shall be increased by a quantity equal to the thickness which the leaves will have at the place of this diameter, it will be sufficient to round, in the form of a demicone, all the parts by which the leaves have been lengthened : by means of this precaution all shocks will be avoided.

If it be required that the parts by which the leaves are lengthened should be curved in such a manner, that the wheel may move the pinion with as much regularity when its teeth meet with the leaves before the plane of the axes, and impel them by their curved parts, as when they impel them by their plane sides, beyond the plane of the axes, it will be necessary to make the curvatures of the ends of these leaves in the form of spherical epicycloids, generated by the rolling of a right cone, having for diameter the radius of the circle which passes through the origin of the curvatures of all the teeth of the wheel. This right cone, in rolling, will have its axis parallel to that of the wheel, and its apex in the axis of the pinion.

These epicycloids, which will have their commencement at the extremities of the principal diameters of the pinion, being traced out, you must then form the curved surfaces of the ends of the leaves, by means of a straight line which will pass through the apex of the cone of the pinion, and

which must be made to glide along these epicycloids.

This construction and the demonstration of it will be easily understood, if the pinion be considered as a crown-wheel and the wheel as a pinion.

Whether the ends of the leaves be rounded into the form of a demi-cylinder, or be curved in the form of a spherical epicycloid ; it will be necessary, in order to lodge these augmentations of the leaves between the teeth of the wheel, to sink in the rim of that wheel, below the circumference of the circle which passes through the origin of the curvatures of all the teeth, the spaces by which the teeth are separated, and to form the sides of these depressions according to the planes drawn through the axis of the wheel, and through the commencement of the curvatures of the teeth.

A profile of a crown wheel with the pinion in which it acts, is given in fig. 202. The curved parts of the teeth of the wheel are separated from the straight parts of the same teeth by a straight line RES, which represents the circumference of the circle that passes through the origin of the curvatures of these teeth. The plane sides of the leaves of the pinion are also separated from the curved parts of these leaves, by the convex surface of the cone CABT.

BOOK XI.

OF THE NUMBER OF TEETH WHICH THE WHEELS OF A MACHINE OUGHT TO HAVE, THAT TWO OR MORE OF THEM MAY PERFORM IN THE SAME TIME A GIVEN NUMBER OF REVOLUTIONS.

571. In general, there are two kinds of machines : those which serve to multiply the moving power, and those the chief object of which is a regularity of the contemporary motion of certain parts. In the former, it is scarcely ever of any importance that a wheel should perform one turn or a certain number of turns exactly while another performs another certain given number of revolutions ; and the principal object ought to be, that the moving power may be communicated from one part to another with the least loss possible. In the other machines, the preservation of the force, in its communication from one part to another, is not the only thing to be considered ; and it is often essential to them that several parts should perform, in the same time, a certain number of revolutions. As machines proper for measuring time are of this kind, it will be chiefly to the construction of these that we shall apply the art of finding the number of the teeth and of the leaves which wheels and pinions ought to have, to cause the various parts of the machine to perform, in the same time, certain motions or a given number of revolutions.

The methods for finding the numbers of the teeth and leaves which must be given to the wheels

and pinions of a machine, to make both these parts perform, in the same time, a certain number of revolutions, being more or less simple, according as it is possible or not possible to give to the wheels and pinions a sufficient number of teeth to produce exactly these revolutions; and as these methods depend on the same principles, order requires that this book should be divided into three chapters. In the first, we shall explain the general principles on which is founded the art of finding the number of teeth and leaves that ought to be given to wheels and pinions. In the second, an application of these principles will be made to finding the numbers of the teeth and pinions, in the case when the product of the wheels and that of the pinions can be decomposed into factors, which may be the numbers of the teeth and leaves of these wheels and pinions. In the third, an application will be made of the same principles to the same research, when the first products found, as those of the wheels and pinions, cannot be decomposed into factors sufficiently small to be the numbers of the teeth and leaves of these wheels and these pinions.

CHAPTER I.

OF THE GENERAL PRINCIPLES FOR FINDING THE NUMBERS OF THE TEETH AND LEAVES OF WHEELS AND PINIONS.

I.

572. The numbers of the teeth of wheels or pinions must not contain fractions. There cannot,

for example, be a wheel of $60\frac{1}{2}$ teeth, because half a tooth would really be a tooth smaller than the rest; but it would have no other property than that of rendering the division of the wheel unequal, and of causing shocks in the machine.

II.

573. If any given number be decomposed into the factors which compose it, and if all these factors be then multiplied by each other, in any order whatever, the product resulting from all these multiplications will be equal to the number given.

For example, if 17280 be decomposed into all its factors, which are 2, 2, 2, 2, 2, 2, 2, 2, 3, 3, 3, 5, and if all these factors be afterwards multiplied one by the other, giving them any arrangement whatever, the product will always be the number 17280, which was decomposed.

Hence, when there are a great number of factors, such for example as 2, 2, 2, 2, 2, 2, 2, 2, 3, 3, 3, 5, to be multiplied one by the other, in order to form of them one product, they may be divided into any number of bands at pleasure; (2, 2, 2, 2, 3) (2, 2, 2, 3, 3) (5), and having multiplied by each other the factor of each band, to reduce them to the compound factors 48, 72, 5, these new factors may be multiplied by each other, and the product will be the number 17280, from which all the given factors were drawn.

Theorem.

574. *Whether the wheel move the pinion or the*

pinion the wheel (fig. 205), the number of the turns of the wheel multiplied by the number of its teeth, is equal to the number of turns which the pinion makes, in the same time, multiplied by the number of its leaves; so that the numbers of the contemporary turns of the wheel and pinion are reciprocally proportional to the numbers of their teeth.

Demonstration.

Let the numbers of the teeth of the wheel A and of the pinion F be represented by the large letters A, F; and the numbers of their contemporary revolutions by the small letters *a*, *f*.

It is to be demonstrated, that we shall have $a \times A = f \times F$, and consequently $a : f :: F : A$.

1st. The number of the teeth of the wheel being represented by A, at each turn made by the wheel, a certain number of teeth, represented by A, will be engaged in the pinion. While the wheel, therefore, makes a certain number of turns, represented by *a*, it will be engaged in the pinion with a certain number of teeth, represented by $a \times A$.

2nd. Since F represents the number of the leaves of the pinion: at each turn made by the pinion it will be engaged in the wheel with a certain number of teeth represented by F. While the pinion, therefore, performs the number of revolutions expressed by *f*, it will be engaged in the wheel with a number of leaves represented by $f \times F$.

But while the wheel and the pinion perform their contemporary revolutions, as many teeth of the wheel will be engaged in the pinion, as there will

be leaves of the pinion engaged in the wheel; therefore we shall have $a \times A = f \times F$; and considering the two members of this equation as the products of the extremes and means of a proportion, we shall have $a : f :: F : A$. Q. E. D.

Corollary I.

575. Since $a \times A = f \times F$ (fig. 205), or $a : f :: F : A$, we shall have $a = \frac{f \times F}{A}$ and $f = \frac{a \times A}{F}$; that is to say, the number of the revolutions of the wheel will be equal to the product of the number of the contemporary revolutions, and of the number of the leaves of the pinion, divided by the number of the teeth of the wheel; and the number of the revolutions of the pinion will be equal to the product of the number of the contemporary revolutions, and of the number of the teeth of the wheel, divided by the number of the leaves of the pinion.

Hence when the wheel makes only one revolution, that is to say, when we have $a = 1$, the number of the revolutions of the pinion will be equal to the number of the teeth of the wheel, divided by the number of the leaves of the pinion: for we shall then have $f = \frac{A}{F}$.

And, when the pinion makes only one revolution, that is to say, when $f = 1$, the number of the revolutions of the wheel will be equal to the number of the leaves of the pinion, divided by the number of the teeth of the wheel; because we shall then find $a = \frac{F}{A}$.

Corollary II.

576. When the wheel A moves the pinion F; when a second wheel B fixed to that pinion (fig. 206) moves a second pinion G; when a third wheel C, fixed to this second pinion, acts in a third pinion H; and when a fourth wheel D, attached to the third pinion, moves a fourth pinion I, &c.; if the numbers of the teeth and leaves of these wheels and pinions be represented by the large letters A, B, C, D, F, G, H, I, &c.; and if the numbers of the contemporary turns made by the wheel A, and the pinions F, G, H, I, &c. be denoted by the small letters *a, f, g, h, i*, &c. we shall find (574)

1st. - - - - - $a : f :: F : A$

2nd. The contemporary revolutions of the pinion F, or the wheel B, and of the pinion G, being represented by *f, g*, we shall have - - - - - $f : g :: G : B$

3rd. The contemporary turns of the pinion G, or of the wheel C and of the pinion H, being denoted by *g, h*, we shall have - - - - - $g : h :: H : C$

4th. The contemporary turns of the pinion H, or of the wheel D, and of the pinion I, being expressed by *h, i*, we shall have - - - - - $h : i :: I : D$

Therefore, by multiplying all these proportions in order, we shall have $a : i :: F \times G \times H \times I : A \times B \times C \times D$; from which we deduce $a \times A \times B \times C \times D = i \times F \times G \times H \times I$, and $i = \frac{a \times A \times B \times C \times D}{F \times G \times H \times I}$: that is to say, the number of the

revolutions of the first wheel A, multiplied by the product of the numbers of the teeth of all the wheels, will be equal to the number of the revolutions of the last pinion I, multiplied by the product of the numbers of all the pinions, and the number of the revolutions of the last pinion will be equal to the number of the revolutions of the first wheel, multiplied by the product of the numbers of the teeth of all the wheels, and divided by the product of the number of the leaves of all the pinions.

It thence follows, that if $a = 1$, that is to say, if the first wheel A makes only one turn, we shall have $A \times B \times C \times D = i \times F \times G \times H \times I$; and

$i = \frac{A \times B \times C \times D}{F \times G \times H \times I}$. That is to say, the product

of all the wheels will be equal to the number of the revolutions made by the last pinion, during a revolution of the first wheel, multiplied by the product of all the pinions; and the number of the revolutions of the last pinion, during a revolution of the first wheel, will be equal to the product of all the wheels, divided by the product of all the pinions.

If we wished to consider only the three wheels successively A, B, C (fig. 207), and the three pinions F, G, H, which act in them; or if the machinery were composed only of the three wheels A, B, C, and the three pinions F, G, H, we should have only these three proportions:

$$a : f :: F : A$$

$$f : g :: G : B$$

$$g : h :: H : C,$$

which being multiplied, in order, would give

$$a : h :: F \times G \times H : A \times B \times C,$$

whence we should deduce $a \times A \times B \times C = h \times F \times G \times H$; and $h = \frac{a \times A \times B \times C}{F \times G \times H}$; and if the

wheel A made only one revolution, we should find $A \times B \times C = h \times F \times G \times H$; and $h = \frac{A \times B \times C}{F \times G \times H}$,

that is to say, the product of all the wheels of that machine would still be equal to the product of all its pinions, multiplied by the number of the revolutions made by the last of these pinions, during a revolution of the first wheel A; and the number of the revolutions which the last pinion would make, during a revolution of the wheel A, would be equal to the product of all the wheels, divided by the product of all the pinions.

Were we to consider only the two first wheels A, B (fig. 208), and the two first pinions F, G; or if the machine were composed only of two wheels A, B, and two pinions F, G, we should have only these two proportions:

$$a : f :: F : A$$

$$f : g :: G : B,$$

which being multiplied, in order, would give

$$a : g :: F \times G : A \times B;$$

whence we should deduce $a \times A \times B = g \times F \times G$;

and $g = \frac{a \times A \times B}{F \times G}$; and if the wheel A made

only one turn, that it is to say, if $a = 1$, we should have $A \times B = g \times F \times G$, and $g = \frac{A \times B}{F \times G}$. In this

machine, therefore, as in all the others, the product of the wheels will be equal to the product of the pinions, multiplied by the number of revolutions which the last pinion makes, during a revolution of the first wheel; and the number of the revolutions which the last pinion makes, during a revolution of the first wheel, will be equal to the product of the wheels divided by the product of the pinions.

In general, then, whether the machine contains a wheel A and a pinion F (fig. 205), or two wheels A, B, and two pinions (fig. 208), or three wheels and three pinions (fig. 207), or any greater number of wheels, and a like number of pinions (fig. 206), if we call the product of all the wheels W, and the product of all the pinions P, and if p represent the number of the revolutions made by the last pinion during one revolution of the first wheel A, we shall have $W = p \times P$ and $p = \frac{W}{P}$.

Corollary III.

577. As the number of the teeth of each wheel ought to be without a fraction (572), the product W of all the wheels must be a whole number; and the product $p \times P$, which must be equal to W, will also be a whole number. Hence, when p , which represents the number of the revolutions made by the last pinion, during a revolution of the wheel A, contains any fraction which cannot become a whole number, unless when multiplied by a number equal to its denominator, or a multiple of that denominator, the product of the pinions P, which is always

a whole number, must be equal to the denominator of that fraction, or a multiple of that denominator.

Corollary IV.

578. Considering the equation $W = p \times P$, it will be readily perceived,

That if the number assumed as the value of P , which represents the product of the pinions, is not too great to be the number of the leaves of one pinion; and if after multiplying that number by the number of revolutions which the last pinion ought to make, the product is not too large to be the number of the teeth of a wheel, the machine might be composed of one wheel A (fig. 205) and one pinion F , if nothing else prevent it. But if the number taken for P , that is to say, for the product of the pinions, is too great to be the number of the leaves of one pinion; or, if after this number has been multiplied by the number of the revolutions which the last pinion ought to make during one revolution of the wheel A , the product is too great to be the number of the teeth of one wheel; that product must be decomposed into as many factors as may be necessary, in order that none of these factors may be greater than the number of the teeth that can be given to a wheel; and these factors must be taken as the numbers of the teeth of so many wheels. The number represented by P must then be divided into as many factors as there are wheels assumed, in order to make it the numbers of the leaves of so many pinions.

But if the number necessary to be taken for P ,

or for the product of the pinions, be a simple number, that is to say, if it can not be decomposed into several integral factors less than itself; and if this number be too large in regard to the size of the parts of the machine, to be the number of the leaves of one pinion; or if after decomposing this number into several factors there are some indecomposable and too great to be the number of the leaves of a pinion, the last pinion, during a revolution of the first wheel, cannot make the number of revolutions required; it will, therefore, be necessary to have recourse to an approximation, neglecting the least part possible of the number of revolutions required.

Even when the number which represents the product P of the pinions can be decomposed into as many factors, as small as possible; if when this number has been multiplied by p , or that of the revolutions which the last pinion ought to make during one revolution of the wheel A , the product be a simple number, and too great to be the number of the teeth of a wheel; or if after this product has been decomposed into several simple factors, there be any of them too great to be the number of the teeth of a wheel, it will be still necessary to cause the last pinion to make a number of revolutions greater or less by a small quantity than that represented by the letter p .

According as the numbers found for the product of the pinions, and for that of the wheels, can or cannot be decomposed into factors, which do not exceed the numbers of the leaves and teeth which can or cannot be given to the pinions and the

wheels of the machine to be constructed, the problem for finding the numbers of the leaves and teeth of these pinions and wheels, requires operations more or less simple, which will be explained in the two following chapters.

CHAPTER II.

CALCULATION OF THE NUMBER OF THE TEETH AND LEAVES OF WHEELS AND PINIONS, IN THE CASE WHEN THE PRODUCT OF THE WHEELS AND THAT OF THE PINIONS CAN BE DECOMPOSED INTO FACTORS, WHICH DO NOT EXCEED THE NUMBERS OF THE TEETH AND LEAVES THAT CAN BE GIVEN TO THESE WHEELS AND PINIONS.

AS the method for finding the numbers of the teeth and leaves of the wheels and pinions is chiefly useful in the construction of clocks, and as examples will be sufficient to give an idea of it, this chapter will contain only two problems, the object of which will be clocks.

Problem.

579. *To find the number of the teeth and leaves which must be given to the wheels and pinions of a clock, in order that it may indicate hours, minutes, and seconds, and having a balance which ought to beat seconds.*

Solution.

A clock which indicates hours, minutes, and seconds (fig. 209), has three indices K, L, M. The

first of these indices K, generally makes a revolution in twelve hours, and points out the hours on a dial plate, divided into twelve equal parts. The second, L, performs a revolution in one hour, or sixty minutes, and marks the minutes on a plate, divided into sixty equal parts; and the third, M, performs its revolution in one minute, or sixty seconds, and marks the seconds on a plate divided also into sixty equal parts.

As it is in some measure necessary that the three wheels A, C, E, the axles of which bear the indices of the hours, minutes, and seconds, should turn the same way, they must not be placed in succession; but one wheel B must be placed between the wheels A and C, which bear the indices of the hours and minutes; and another wheel D, must be placed between the wheels C and E, which bear the indices of the minutes and seconds. The whole, therefore, of the wheel-work necessary to make a clock indicate, hours, minutes and seconds, consists of five wheels, A, B, C, D, E, which communicate motion to each other by means of four pinions F, G, H, I.

1st. As the pendulum of the clock ought to beat seconds, that is to say, make sixty vibrations in a minute, and as each tooth of the wheel E will cause it to make two vibrations, it is evident that by giving thirty teeth to that wheel, it will perform its revolution in a minute; that is to say, while the pendulum makes sixty vibrations. Here then we have determined the number of the teeth of the wheel E.

2d. To find the numbers of the teeth and of the leaves of the two wheels C, D, and of the two pinions H, I, in which they act, it is first to be remarked, that as the pinion I of the wheel, which bears the index of the seconds, must perform a revolution in a minute, it will make sixty revolutions while the wheel which bears the index of the minutes performs only one.

But if the letters C, D, H, I, represent the numbers of the teeth and leaves of the two wheels and two pinions, denoted by the same letters, we shall find $(576) 60 \times H \times I = C \times D$. Hence, by taking for H and I any number of leaves at pleasure, we shall have the value of the product $C \times D$ of the numbers of the teeth which the two wheels C and D ought to have.

If six leaves be given to each of the two pinions H, I, the equation $60 \times H \times I = C \times D$ will become $60 \times 6 \times 6 = C \times D$. We must, therefore, divide $60 \times 6 \times 6$ into two factors, which may be the numbers of the teeth of the two wheels C, D. To choose these two factors with most convenience, we shall decompose the number $60 \times 6 \times 6$ into all the factors 2, 2, 3, 5, 2, 3, 2, 3, of which it is composed. We shall then divide all these factors into two bands, at pleasure, such for example as the following: (2, 2, 2, 2, 3), (5, 3, 3), and the two numbers 48 and 45, found by multiplying the factors of each band together, will be the numbers of the teeth of the two wheels C and D.

The same factors 2, 2, 3, 5, 2, 3, 2, 3, might have been divided into two other bands (2, 2, 3, 5), (2, 3,

2, 3), and the numbers 60 and 36 resulting from the multiplication of the factors of each band might have been taken as the numbers of the teeth of the same wheels C and D. But as it is proper that there should be as little inequality as possible between the wheels C and D, though this is not necessary, the two former numbers 48 and 45 are preferable to the latter 60 and 36.

3d. To determine the numbers of the teeth and leaves of the two wheels A and B, and of the two pinions F and G, in which they act, it is to be remarked, that as the pinion G, which bears the index of the minutes, makes a revolution in an hour, it will perform twelve revolutions while the wheel A, which bears the index of the hours, performs only one. Hence, if the letters A, B, F, G, represent the numbers of the teeth and leaves of the two wheels and the two pinions indicated by the same letters, we shall have (576) $12 \times F \times G = A \times B$; whence it follows, that by taking for F and G any numbers at pleasure, we shall have the value of the product of the two wheels A and B.

If eight leaves be given to the pinion F, and sixteen to the pinion G, which ought to be larger than the rest, because its arbor is a hollow cylinder fitted on the axle of the wheel C, and which bears the index of the minutes, the equation $12 \times F \times G = A \times B$, will become $12 \times 8 \times 16 = A \times B$. Hence it will be necessary to divide the number $12 \times 8 \times 16$ into two factors, to have the numbers of the teeth of the two wheels A and B.

To choose more easily these two factors, first

decompose the number $12 \times 8 \times 16$ into all its factors, which will make 2, 2, 3, 2, 2, 2, 2, 2, 2, 2, then arrange all these factors into any two bands at pleasure, such for example, as the following: (2, 2, 2, 2, 3), (2, 2, 2, 2, 2), and the two numbers 48 and 32, found by multiplying together the factors of each band, will be the numbers of the teeth of the two wheels A and B.

The numbers of the teeth of the five wheels A, B, C, D, E, may therefore be 48, 32, 48, 45, 30, taking 8, 16, 6, 6, as the numbers of the leaves of the four pinions F, G, H, I.

It is proper to remark, that the moving power is never applied to the wheel A of the hours, nor to that B, which acts in the pinion G, the hollow cylinder of which bears the index of the minutes, but is applied to the wheel C, when it is required that the clock should go only thirty or thirty-six hours, or to any other wheel R (fig. 210, 211) added to cause the clock to go eight or ten days without winding up; and that this new wheel R, which may have any number of teeth at pleasure, acts in the pinion borne by the axis of the minute wheel C.

Problem.

580. *To find the numbers of the teeth and leaves of the wheels and pinions for a watch, which is to indicate the hours and minutes, and whose balance ought to perform 17280 vibrations in an hour.*

Solution.

Without paying attention to the arrangement

given to the wheels of a watch, let A (fig. 210, 211) be the wheel which bears the hour-hand, and which performs its revolution in twelve hours; C, that which carries the minute-hand, and makes its revolution in one hour; and F, the escapement wheel, which acts in the pallets of the balance, and which in general has an odd number of teeth.

During one revolution of the wheel F, each tooth of that wheel will cause the balance to make two vibrations; therefore if F represent the number of the teeth of that wheel, $2 F$ will be the number of the vibrations which the balance will make on each revolution of the wheel F.

If C, D, E, I, K, L represent the numbers of the teeth and the leaves of the wheels and the pinions, denoted by the same letters, the number of the revolutions made by the pinion L, or the wheel F, during a revolution of the wheel C, will be expressed

(576) by $\frac{C \times D \times E}{I \times K \times L}$. Therefore, if this number

of the revolutions $\frac{C \times D \times E}{I \times K \times L}$ of the wheel F be

multiplied by the number of vibrations $2 F$, which the balance will make during a revolution of that

wheel, the product $\frac{C \times D \times E \times 2 F}{I \times K \times L}$, will be the

number of the vibrations which the balance will make during a revolution of the wheel C.

But by a condition of the problem, the balance ought to make 17280 vibrations per hour, or during a revolution of the wheel C. Therefore,

$$\frac{C \times D \times E \times 2F}{I \times K \times L} = 17280, \text{ or } C \times D \times E \times 2F = 17280 \times I \times K \times L, \text{ or in the last place } C \times D \times E \times F = \frac{17280}{2} \times I \times K \times L; \text{ that is to say, the pro-}$$

duct of the wheels C, D, E, F will be equal to the product of the pinions I, K, L, multiplied by half the number of the vibrations which the balance makes during a revolution of the wheel C. Therefore, by giving to the pinions I, K, L, any numbers of leaves at pleasure, we shall have the value of the product $C \times D \times E \times F$ of the wheels.

Let us suppose that six leaves are given as is usual to each of the pinions I, K, L; the equation

$$C \times D \times E \times F = \frac{17280}{2} \times I \times K \times L, \text{ will become}$$

$$C \times D \times E \times F = \frac{17280}{2} \times 6 \times 6 \times 6, \text{ or } C \times D \times E$$

$\times F = 8640 \times 6 \times 6 \times 6$. Therefore to find the numbers of the teeth of the four wheels C, D, E, F, we must decompose the number $8640 \times 6 \times 6 \times 6$ into four factors.

To find more conveniently the four factors or four numbers of the teeth, best suited to the four wheels, C, D, E, F, decompose the number $8640 \times 6 \times 6 \times 6$, into all its factors, 2, 2, 2, 2, 2, 2, 3, 3, 3, 5, 2, 3, 2, 3, 2, 3; and having chosen some of them, the product of which may be the number of the teeth of the escapement wheel F, divide the rest into three bands, the products of which will be the numbers of the teeth that can be given to the three wheels C, D, E.

But before the factors of the escapement wheel F be chosen, it is necessary to make the following remarks:

1st. The teeth of that wheel must be larger or farther distant from each other than those of the other wheels; it ought, therefore, to have fewer teeth than the rest: in watches, it has never fewer than thirteen teeth, and never more than seventeen, unless it be very large.

2d. When the teeth of the escapement wheel strike alternately the two pallets of a common balance, the number of them ought to be odd; for the verge of the balance must pass through opposite to the middle of that wheel, in order that its teeth may make alternately equal impressions on the two pallets. But the verge of the balance being thus disposed, if the number of the teeth of the escapement wheel were even, two opposite teeth of that wheel would meet at the same time, and in the same manner the two pallets, and the balance being impelled at the same time by two equal and opposite forces, would stop. On the other hand, if the number of the teeth of the escapement wheel were odd, all its teeth would be diametrically opposite to its spaces. While one pallet, therefore, would be met with and impelled by one tooth, the other pallet would be free in the space opposite to that tooth; so that the teeth of the escapement wheel would never touch both pallets at the same time, but would fall upon them alternately, to give the balance vibrations alternately contrary.

As none of the factors into which we have de-

composed the product of the four wheels C, D, E, F, can produce either thirteen or seventeen, which are the limits of the number of teeth that can be given to the escapement wheel of a watch; and as the number sixteen, composed of the factors 2, 2, 2, 2, is not proper for that wheel, because it is even; we shall be obliged to take fifteen, or the product of the two factors 3 and 5, as the number of the teeth of the wheel F: we shall then distribute the rest of the factors into three bands, such for example as the following (2, 3, 3, 3) (2, 2, 2, 2, 3) (2, 2, 2, 2, 3) the products of which will be 54, 48, 48, and we shall have 54, 48, 48, and 15, as the numbers of the teeth of the four wheels C, D, E, F.

As the wheel A, which bears the index of the hours, ought to make only one revolution in twelve hours, that is to say, while the wheel of the minutes C performs twelve revolutions; if A, B, G, H, be made to represent the numbers of the teeth and leaves of the pinions, denoted by the same letters, we shall have, as in the preceding problem, $12 \times G \times H = A \times B$; therefore, by taking for the pinions G and H any numbers at pleasure, we shall have the value of the product of the wheels A and B.

If ten leaves be given to the pinion G, and twelve to the pinion H, which must form one piece with the hollow cylinder, that bears the index of the minutes, the equation $12 \times G \times H = A \times B$ will become $12 \times 10 \times 12 = A \times B$; therefore by taking all the factors 2, 2, 3, 2, 5, 2, 2, 3, of the number $12 \times 10 \times 12$, and dividing them into any two bands, such as (2, 2, 2, 5), (2, 2, 3, 3), the two products

40 and 36, found by multiplying together the factors of each band, will be the numbers of the teeth of the wheels A and B, and the problem will be completely solved.

To cause watches to go thirty hours, there is added a seventh wheel R, of forty-eight teeth, made to act in a pinion of twelve leaves, which generally forms one piece with the minute wheel; and there is placed on the arbor of that wheel R, a conical fusee cut into a spiral form, in the groove of which a chain makes $7\frac{1}{2}$ turns. One end of the chain is affixed to the bottom of the fusee, and the other end to a barrel, inclosing a spring, and this spring causes the barrel to make a sufficient number of turns to be charged with a quantity of the chain, equal to that which is in the grooves of the fusee. It is to be remarked that the barrel is made as large as possible, in regard to the size of the case of the watch, that the spring may have more freedom to act, and be better able to cause the barrel to make the number of turns necessary for it to take up the chain.

It is to be remarked, that the arrangement given to the wheels, fig. 210, in regard to this problem, must be considered only as a disposition which shews more distinctly the pieces, the numbers of the teeth of which are to be found; and that this arrangement is not suited to a watch, the wheels of which bearing the index of the minutes and that of the hours, ought to be concentric, and in which the escapement wheel has its axis parallel to the plane of the other wheels. But the disposition of the same wheels is better shewn in fig. 211.

CHAPTER III.

TO FIND THE NUMBERS OF THE TEETH AND LEAVES OF WHEELS AND PINIONS, IN THE CASE WHEN THE PRODUCT OF THE WHEELS AND THAT OF THE PINIONS CANNOT BE DECOMPOSED INTO FACTORS, WHICH DO NOT EXCEED THE NUMBERS OF THE TEETH AND LEAVES THAT CAN BE GIVEN TO THESE WHEELS AND PINIONS.

IN machines of the same kind as those alluded to in the preceding chapter, one may give to the pinions any number of leaves at pleasure, and if one were obliged to employ wheels already made, or which serve for some particular revolutions, and to find some pinions, it may be readily seen that it might easily be accomplished by the methods and formulæ already given. But in the wheel work, which forms the subject of this chapter, the artist is not allowed to give to any pinion whatever number of teeth he chooses. It is, therefore, necessary to search, not only for the numbers of the teeth of the wheels, but for those also of the leaves of the pinions. As a few examples will be sufficient to illustrate the method which ought to be followed for this purpose, we shall give only two in the form of problems, the object of which will be the annual motion of the sun or of the earth, and the synodical revolution of the moon intended to be indicated by a clock.

Problem.

581. *To find the number of the teeth and leaves of*

the wheels and pinions of a machine, which being moved by a pinion, placed on the hour wheel, shall cause a wheel to make a revolution in a mean year, supposed to consist of 365 days, 5 hours, 49 minutes.

Solution.

Let A (fig. 212) be the wheel which ought to perform a revolution in 365 days, 5 hours, 49 minutes; H, the pinion, to be placed on the hour wheel; and which like that wheel will make a revolution in 12 hours; and B, C, F, G, two other wheels and two other pinions, by means of which the motion of the pinion H will be communicated to the wheel A.

As the pinion H makes a revolution in 12 hours, or two revolutions in a day, it will make 730 revolutions in 365 days, and $\frac{5}{12}$ or $\frac{300}{720}$ of a revolution in five hours; and as a minute is equal to $\frac{1}{60}$ of an hour, or $\frac{1}{720}$ of 12 hours, the same pinion will perform $\frac{49}{720}$ of a revolution in 49 minutes. This pinion, therefore, will make $730\frac{349}{720}$ revolutions in 365 days, 5 hours, 49 minutes; that is to say, during the time that the wheel A ought to perform its revolution.

But the product of the wheels A, B, C, is equal (576) to the product of the pinions F, G, H, multiplied by the number of the revolutions made by

the pinion H during a revolution of the wheel A. We shall, therefore, have this equation $A \times B \times C = 730 \frac{349}{720} \times F \times G \times H$.

As the numbers of the teeth of the wheels ought not to contain fractions, the value $730 \frac{349}{720} \times F \times G \times H$ of their product must be a whole number.

Therefore, if the number $730 \frac{349}{720}$ be multiplied by the product $F \times G \times H$ of the pinions, the fraction which has 720 for denominator, must become a whole number; consequently this product of the pinions $F \times G \times H$ must be equal to 720, or be a multiple of 720.

If the product $F \times G \times H$ of the pinions were made equal to the number 720, which might be decomposed into these three factors, 8, 9, 10, which might be taken as the numbers of the leaves of these pinions, the equation $A \times B \times C = 730 \frac{349}{720} \times F \times G \times H$ would become $A \times B \times C = 525949$. But as the number 525949, found as the product of the numbers of the teeth of the three wheels A, B, C, cannot be decomposed into three factors, which might be the numbers of the teeth of these wheels, it must be concluded that it is not possible to cause the wheel A to make a revolution in 365 days, 5 hours, 49 minutes.

If a number a multiple of 720 were taken as the product of the pinions, nothing would be gained;

as we should find, for the product of the wheels A, B, C, a number a multiple of 525949, and this multiple could not be decomposed better than 525949.

As the number $730\frac{349}{720}$ multiplied by any other product of pinions than 720, or than a multiple of 720, would not give a product without fractions for that of the wheels; and as the fractions must be neglected in the product of the wheels A, B, C; it is necessary to find for the product of $F \times G \times H$ of the pinions a whole number, which being multiplied by $730\frac{349}{720}$ may give a product as near as possible to a whole number. In general, this is done by repeated trials; but as this method is defective, we shall here propose another, by which the problem may be solved with more certainty.

When in searching for the value of the product $A \times B \times C$ of the wheels, or to approach as near to it as possible, you have multiplied $730\frac{349}{720}$ by the product $F \times G \times H$ of the pinions which will be a whole number; the product found will be composed of these two parts $730 \times F \times G \times H$, and $\frac{349 \times F \times G \times H}{720}$. But the first part $730 \times F \times G \times H$ of this product will be a whole number, since its two factors 730 and $F \times G \times H$ are whole numbers. We must therefore proceed in such a manner, that the second part $\frac{349 \times F \times G \times H}{720}$ may approach as near as possible to a whole number.

In order that the fraction $\frac{349 \times F \times G \times H}{720}$ may approach as near as possible to a whole number, it is necessary that its numerator, which is a whole number, should be too large or too small, only by unity, to be divided by its denominator 720. But if we suppose that this numerator is too great, by unity, and if we lessen it by that unity, we shall have $\frac{349 \times F \times G \times H - 1}{720}$, equal to a whole number.

If this whole number then be represented by S, we shall have $\frac{349 \times F \times G \times H - 1}{720} = S$.

If each member of this equation be multiplied by 720, we shall have $349 \times F \times G \times H - 1 = 720 S$. Adding 1 then to each member of the last equation, and dividing each of its new members by 349, it will be reduced to the following $F \times G \times H = \frac{720 S + 1}{349}$.

349

As the product $F \times G \times H$ of the pinions which forms the first member of the last equation, is a whole number, the second member $\frac{720 S + 1}{349}$ of the same equation, will be also a whole number. But this whole number $\frac{720 S + 1}{349}$ is composed of two parts $\frac{698 S}{349}, \frac{22 S + 1}{349}$; and the first of these two parts is a whole number, because it is equal to $2 S$; the second part therefore $\frac{22 S + 1}{349}$ is also a

whole number, which we shall suppose to be represented by T , in order to have a new equation

$$\frac{22S + 1}{349} = T.$$

If the two members of this equation be multiplied by 349, then lessened by 1 and divided by 22, we shall have $\frac{S = 349T - 1}{22}$.

But the letter S , which forms the first member of this equation, was assumed to represent a whole number: therefore, the second member $\frac{349T - 1}{22}$ will also be a whole number. But this whole number $\frac{349T - 1}{22}$ is composed of these two parts $\frac{330T}{22}$, $\frac{19T - 1}{22}$, the former of which is a whole number, since it is equal to $15T$, and T represents a whole number: therefore, the second, part $\frac{19T - 1}{22}$ is also a whole number which we shall represent by V , in order to have a new equation $\frac{19T - 1}{22} = V$.

If the two members of this last equation be first multiplied by 22, then increased by unity and divided by 19, we shall have $\frac{T = 22V + 1}{19}$: and as T represents a whole number $\frac{22V + 1}{19}$ will be a whole number also.

But the whole number $\frac{22V+1}{19}$ is composed of two parts $\frac{19V}{19}$, $\frac{3V+1}{19}$; and the first part $\frac{19V}{19}$ being equal to V , is a whole number; the second part $\frac{3V+1}{19}$ will be also a whole number, which we shall represent by X , to have another equation $\frac{3V+1}{19} = X$.

The two members of this equation being multiplied by 19, then lessened by unity and divided by 3, we shall have $V = \frac{19X-1}{3}$; and as V represents a whole number, $\frac{19X-1}{3}$ will represent a whole number also.

But the whole number $\frac{19X-1}{3}$ is composed of these two parts $\frac{18X}{3}$ and $\frac{X-1}{3}$; the former of which is a whole number; the second, therefore, $\frac{X-1}{3}$ will also be a whole number, or equal to Zero.

If $\frac{X-1}{3}$ be made equal to zero, we shall have $X=1$; and the product $F \times G \times H$ of the pinions may be found by simple substitutions.

For putting 1 for X in the equation $V = \frac{19X-1}{3}$, we shall find $V=6$;

Then putting 6 for V in the equation $T = \frac{22V + 1}{19}$, we shall have $T = 7$:

Putting 7 for T in the equation $S = \frac{349T - 1}{22}$ we shall have $S = 111$.

In the last place, putting 111 for S in the equation $F \times G \times H = \frac{720S + 1}{349}$, the product of the pinions $F \times G \times H$ will be found = 229.

As the number 229 found for the value of the product $F \times G \times H$ of the pinions is a simple number, which cannot be decomposed into several factors, and as it exceeds the number of the leaves that can be given to a pinion, it will be necessary to seek for another more convenient.

If instead of making $\frac{X - 1}{3} = \text{Zero}$, it had been made successively equal to 1, to 2, to 3, &c. we should have found as the product $F \times G \times H$ of the pinions, other numbers 949, 1669, 2389; &c. formed by the continual addition of 720 to 229; but as these new products are simple numbers, or composed of factors too great to be the numbers of the leaves of pinions, or give as the product of the wheels, numbers composed of factors too great, they cannot be employed. In a word, this article is not demonstrated, because there are no rules to enable us to determine whether a number resulting from these compositions will be simple, or composed of several factors of a certain quantity.

As the number 229 cannot be the product

of several pinions F, G, H, we will search for another, which being multiplied by 349 shall give a product too great by 2 or three to be divisible by 720; that is to say, we will make

$$\frac{349 \times F \times G \times H - 2}{720}, \quad \text{or} \quad \frac{349 \times F \times G \times H - 3}{720}$$

equal to a whole number, represented by S, repeating the operations, above explained in the case where it was required that $\frac{349 \times F \times G \times H - 1}{720}$

should be a whole number; and we shall have the following equations, which will differ from the first only in this, that they will contain + 2 and - 2, or + 3 and - 3, instead of + 1 and - 1, which were in the first.

$$\left. \begin{aligned} F \times G \times H &= \frac{720 S + 2}{349} \\ S &= \frac{349 T - 2}{22} \\ T &= \frac{22 V + 2}{19} \\ V &= \frac{19 X - 2}{3} \\ X &= 2 \end{aligned} \right\} \text{or} \left\{ \begin{aligned} F \times G \times H &= \frac{720 S + 3}{349} \\ S &= \frac{349 T - 3}{22} \\ T &= \frac{22 V + 3}{19} \\ V &= \frac{19 X - 3}{3} \\ X &= 3 \end{aligned} \right.$$

But if to find the value of the product $F \times G \times H$ of the pinions we substitute in these two new series of equations, 2 or 3 in the place of X, in the value of V, then the value of V in the room of T, and that of T in the room of S, and the value of S in that of the product $F \times G \times H$ of the pinions, we shall find for that product 458, which is the double

of 229, or 687 which is the triple of 229; and as we rejected 229, because it is indecomposable, and too great to be the number of the leaves of the pinion, we must reject also the two numbers 458 and 687, which both have the same number 229 as one of their factors.

But if we endeavour to find for the product $F \times G \times H$ of the pinions, a number which being multiplied by 349, shall give a product too great, by 4 units, to be divisible by 720; that is to say, if it be required that $\frac{349 \times F \times G \times H - 4}{720}$ should be a

whole number, we shall have the following equations, which differ from the former only in this, that they will contain + 4 or - 4, whereas the first contained + 1 or - 1.

$$F \times G \times H = \frac{720 S + 4}{349}$$

$$S = \frac{349 T - 4}{22}$$

$$T = \frac{22 V + 4}{19}$$

$$V = \frac{19 X - 4}{3}$$

And as the value $\frac{19 X - 4}{3}$ of the whole number V is composed of these two parts $\frac{18 X - 3}{3}$ $\frac{X - 1}{3}$; and as the first $\frac{18 X - 3}{3}$, of these two parts is a whole number, the second part $\frac{X - 1}{3}$ will be a whole number also, or equal to zero.

But if we make $\frac{X-1}{3} = \text{zero}$, we shall have $X = 1$.

If 1 be substituted for X in $\frac{19X-4}{3}$, the value of V , we shall have $V = 5$.

Putting 5 for V in $\frac{22V+4}{19}$, the value of T , we shall have $T = 6$.

Putting 6 for T in $\frac{349T-4}{22}$, the value of S , we shall have $S = 95$.

And, in the last place, putting 95 for S in $\frac{720S-4}{349}$, the value of $F \times G \times H$, we shall have $F \times G \times H = 196$.

But the number 196, found as the value of the product $F \times G \times H$ of the pinions, is decomposable into these three factors 4, 7, 7; which may be the numbers of the leaves of those three pinions; these pinions therefore are determined.

To determine the numbers of the teeth of the three wheels A, B, C , we shall resume the equation $A \times B \times C = 730 \frac{349}{720} \times F \times G \times H$, which was found in the commencement of the solution; and putting 196 for the product $F \times G \times H$, we shall have $A \times B \times C = 143175 \frac{4}{720}$; and neglecting the fraction $\frac{4}{720}$, which we proposed to reject, we shall have for the product of the wheels A, B, C , the number 143175, which can be easily decomposed into these three factors 25, 69, 83; which may be

the numbers of the teeth of the three wheels A, B, C.

Therefore, to cause a wheel A to make a revolution in 365 days, 5 hours, 49 minutes, nearly, by means of wheel-work moved by the pinion H, placed on the wheel of 12 hours in a clock, we may employ three wheels A, B, C; the numbers of the teeth of which will be 25, 69, 83, and three pinions F, G, H, the numbers of the leaves of which will be 4, 7, 7.

1st. *It is to be remarked that the fraction $\frac{4}{720}$, which has been neglected in the product of the wheels, will not occasion in the required revolution an error of 1" 14"; and that 2940 years would be necessary before that error, by multiplying, could amount to an hour; which would not be sensible in a movement so slow as that of the wheel A. For it is evident, that if we search for the number of revolutions which will be made by the pinion H, during a revolution of the wheel A, dividing the product 143175 of the three wheels A, B, C, by the product 196 of the three pinions F, G, H, we shall find that the pinion H will make 730 revolutions, which correspond to 365 days; and that there will remain 95 revolutions, which will correspond to 95 times 12 hours, or 1140 hours to be divided by 196. But if 1140 hours be divided by 196, we shall have five hours; and there will remain 160 hours, or 9600 minutes, to be divided by 196. If we divide these 9600 minutes by 196, we shall find 48 minutes, with a remainder of 192 minutes, or 11520 seconds, which being divided by 196, will give*

58 seconds, with a remainder of 152 seconds, or 9120 thirds, which, being divided by 196, will give 46 thirds. The time, therefore, which the wheel A will employ in making one revolution, will be 365 days, 5 hours, 48 minutes, 58 seconds, 46 thirds, and more; consequently will not be less by 1" 14'" than the time proposed.

2d. It ought to be remarked, that the tropical year is shorter by about 2 seconds than 365 days, 5 hours, and 49 minutes, which were taken as the mean year. The time, therefore, which the wheel A will employ in making a revolution, will approach as near as might be wished to the duration of the mean year.

3d. In the last place, it is to be remarked, that in endeavouring to find as the product $F \times G \times H$ of the pinions, a number which being multiplied by $730 \frac{349}{720}$,

may give a product approaching as near as possible to a whole number, we have made the numerator of

the fraction $\frac{349 \times F \times G \times H}{720}$ greater by 1 or 2 or 3 or

4 units than a number divisible by 720, instead of taking a smaller number; because it is known that the time assumed as the duration of the mean or tropical year ought to be lessened rather than increased.

Besides, had we increased this duration, by making $\frac{349 \times F \times G \times H + 1}{720}$, or $\frac{349 \times F \times G \times H + 2}{720}$, or

$\frac{349 \times F \times G \times H + 3}{720}$, equal to a whole number, we

should have succeeded as badly in finding numbers

proper for the product of the wheels and that of the pinions, as we did by supposing $\frac{349 \times F \times G \times H - 1}{720}$,
 or $\frac{349 \times F \times G \times H - 2}{720}$, or $\frac{349 \times F \times G \times H - 3}{720}$, equal to a whole number.

Problem.

582. To find the numbers of the teeth and leaves of the wheels and pinions of a machine, which being moved by a pinion placed on the spindle of the minute wheel of a clock, shall cause a wheel to make a revolution in 29 days, 12 hours, 44 minutes, 3 seconds, and 12 thirds, which form a mean synodical revolution of the moon.

Solution.

Let A (fig. 212) be the wheel which is to perform a revolution in 29 days, 12 hours, 44 minutes, 3 seconds, and 12 thirds; H the pinion, which being placed on the spindle of the minute-wheel, will, like that wheel, perform a revolution in an hour, and B, C, F, G, two other wheels, and two other pinions, by means of which the motion of the pinion H, will be communicated to the wheel A.

As the pinion H performs a revolution in an hour, or 24 revolutions in a day, it will make 696 revolutions in 29 days, and 708 revolutions in 29 days, 12 hours.

A minute being $\frac{1}{60}$, or $\frac{3600}{216000}$ of an hour, the pi-

nion H will make $\frac{158400}{216000}$ revolutions in 44 minutes.

A second being $\frac{1}{3600}$, or $\frac{60}{216000}$ of an hour, the

pinion H will perform $\frac{180}{216000}$ revolutions in 3 seconds.

A third being $\frac{1}{216000}$ of an hour, the pinion H will make $\frac{12}{216000}$ revolutions in 12 thirds.

While the wheel A, therefore, makes one turn, the pinion H will perform $708 \frac{158592}{216000}$ revolutions, or (dividing the two terms of the fraction by 192) $708 \frac{826}{1125}$ revolutions.

But (576) the product $A \times B \times C$ of the wheels is equal to the product $F \times G \times H$ of the pinions, multiplied by the number of the revolutions which the pinion H performs, during one revolution of the wheel A. We shall therefore have $A \times B \times C = F \times G \times H \times 708 \frac{826}{1125}$.

Therefore, when it is required that the wheel A should perform its revolution in 29 days; 12 hours, 44' 3" 12''' exactly, we must take as the product $F \times G \times H$ of the pinions, a number which may be equal to the denominator of the fraction $\frac{826}{1125}$, or which may be a multiple of that denominator.

But if we take the number 1125 as the value of

the product $F \times G \times H$ of the pinions, and substitute it in the room of that product, in the equation

$$A \times B \times C = F \times G \times H \times 708 \frac{826}{1125},$$

we shall have for the value of the product $A \times B \times C$ of the wheels the number 797326, which cannot be decomposed into factors proper for being the numbers of the teeth of two or three wheels. The wheel A, therefore, cannot be made to perform a revolution in 29 days, 12 hours, 44' 3" 12"; and it will be necessary to find as the product of $F \times G \times H$ of the pinions a whole number, which being multiplied by $708 \frac{826}{1125}$, may give a product approaching, as near as possible, to a whole number.

In searching for the product of the wheels, or endeavouring to approach it, when we have multiplied $708 \frac{826}{1125}$ by the product $F \times G \times H$ of the pinions, the product found will be composed of these two parts $708 \times F \times G \times H$, $\frac{826 \times F \times G \times H}{1125}$.

But as the first part $708 \times F \times G \times H$ will be a whole number, and as the sum of these two parts ought to approach as near as possible to a whole number, it will be necessary to proceed in such a manner, that the second part $\frac{826 \times F \times G \times H}{1125}$ may approach as near as possible to a whole number.

In order that the fraction $\frac{826 \times F \times G \times H}{1125}$ may

differ as little as possible from a whole number, its numerator must be too large or too small, only by unity, to be divisible by 1125. But by making this numerator greater or less, by unity, and even by 2 or 3 or 4 or 5 or 6 or 7 or 8 units, than a number divisible by 1125, we shall find as the product $A \times B \times C$ of the wheels' numbers, some factors ~~of~~ which will be too great to be the numbers of the teeth of some of the wheels; and therefore it will be necessary to proceed in such a manner, that the numerator of that fraction may be 9 units too small, to be divisible by 1125; that is to say, having added 9 to the numerator $826 \times F \times G \times H$, we shall suppose the new fraction $\frac{826 \times F \times G \times H + 9}{1125}$,

equal to a whole number represented by S , which will give this equation $\frac{826 \times F \times G \times H + 9}{1125} = S$.

If the two members of this equation be multiplied by 1125, and if 9 be then taken from each of them, and the remainder divided by 826, we shall have the equation $F \times G \times H = \frac{1125 S - 9}{826}$.

As the first member $F \times G \times H$ of this equation must be a whole number, the second member $\frac{1125 S - 9}{826}$ will be a whole number also.

But this whole number is composed of two parts, $\frac{826 S}{826}, \frac{299 S - 9}{826}$, and the first of these parts is a whole number, since it is equal to S ; the second

part therefore $\frac{299 S - 9}{826}$ will be also a whole number.

If the last whole number be represented by T, we shall have $\frac{299 S - 9}{826} = T$; and if the two members of this equation be multiplied by 826, then increased by 9, and divided by 299, we shall have $S = \frac{826 T + 9}{299}$.

But as the first member S of this equation represents a whole number, the second member $\frac{826 T + 9}{299}$ will represent a whole number also; and as this member is composed of these two parts $\frac{598 T}{299}, \frac{228 T + 9}{299}$, the first of which is a whole number, since it is equal to 2 T, the second part $\frac{228 T + 9}{299}$ will necessarily be a whole number.

If the last whole number be represented by V, we shall have $\frac{228 T + 9}{299} = V$; then multiplying each member of this equation by 299, taking 9 from it, and dividing by 228, we shall have $T = \frac{299 V - 9}{228}$.

As the first member T of this new equation was taken as a whole number, the second member $\frac{299 V - 9}{228}$ will be a whole number also. But as this whole number is composed of these two parts,

$\frac{228 V}{228}$ and $\frac{71 V - 9}{228}$, the former of which is equal to V which is a whole number, the second part $\frac{71 V - 9}{228}$ will be a whole number also.

Let this new whole number be represented by X : we shall then have this equation $\frac{71 V - 9}{228} = X$; and if each of the members of this equation be multiplied by 228, increased by 9, and divided by 71, we shall have $V = \frac{228 X + 9}{71}$.

The first member V of this equation being a whole number, the second $\frac{228 X + 9}{71}$ will be a whole number also; and as it is composed of two parts $\frac{213 X}{71}$, $\frac{15 X + 9}{71}$, the first of which is a whole number, the second $\frac{15 X + 9}{71}$ will be a whole number also.

Let the latter be represented by Y , we shall then have this equation $\frac{15 X + 9}{71} = Y$; and if each of the members be multiplied by 71, lessened by 9, and then divided by 15, the equation will be $X = \frac{71 Y - 9}{15}$.

As the first member X of this equation is a whole number, the second $\frac{71 Y - 9}{15}$ will be one also; and as it may be divided into these two parts $\frac{60 Y}{15}$,

$\frac{11 Y - 9}{15}$, the first of which is a whole number, the second $\frac{11 Y - 9}{15}$ will be a whole number also.

If the latter whole number be represented by Z, we shall have $\frac{11 Y - 9}{15} = Z$; and if each of the two members be multiplied by 15, increased by 9, and divided by 11, we shall have $Y = \frac{15 Z + 9}{11}$.

But the first member of this equation being a whole number, the second $\frac{15 Z + 9}{11}$ will be a whole number also; but it is composed of two parts $\frac{11 Z}{11}$, $\frac{4 Z + 9}{11}$, and the first of these being a whole number, the second $\frac{4 Z + 9}{11}$ will be a whole number also.

Finally: If the last whole number be represented by $\&$, we shall have this equation $\frac{4 Z + 9}{11} = \&$; from which we obtain $\frac{Z = 11 \& - 9}{4}$

But as the first member Z of this equation is a whole number, the second $\frac{11 \& - 9}{4}$ will be one also; and as it is composed of two parts $\frac{8 \& - 8}{4}$ and $\frac{3 \& - 1}{4}$, the first of which is a whole number, the second $\frac{3 \& - 1}{4}$ will be a whole number also.

As the last whole number may be equal to 2, we shall have $\frac{3 \& - 1}{4} = 2$, or $3 \& - 1 = 8$, or $3 \& = 9$, from which we obtain $\& = 3$.

We shall then have the nine following equations, which will give the values of the products $A \times B \times C \times F \times G \times H$ of the wheels and pinions, by simple substitution.

$$\begin{aligned}
 \text{1st.} & \quad - \quad - \quad \& = 3 \\
 \text{2d.} & \quad - \quad - \quad Z = \frac{11 \& - 9}{4} \\
 \text{3d.} & \quad - \quad - \quad Y = \frac{15 Z + 9}{11} \\
 \text{4th.} & \quad - \quad - \quad - \quad X = \frac{71 Y - 9}{15} \\
 \text{5th.} & \quad - \quad - \quad V = \frac{228 X + 9}{71} \\
 \text{6th.} & \quad - \quad - \quad - \quad T = \frac{299 V - 9}{228} \\
 \text{7th.} & \quad - \quad - \quad - \quad S = \frac{826 T + 9}{299} \\
 \text{8th.} & \quad - \quad F \times G \times H = \frac{1125 S - 9}{826} \\
 \text{9th.} & \quad A \times B \times C = F \times G \times H \times 708 \frac{826}{1125}
 \end{aligned}$$

As the first of these equations gives $\& = 3$
 If we put 3 for $\&$ in the 2d, we shall have $Z = 6$
 Putting 6 for Z in the 3d, we shall have $Y = 9$
 Putting 9 for Y in the 4th, we shall have $X = 42$
 Putting 42 for X in the 5th, we shall
 have - - - - - $V = 135$
 Putting 135 for V in the 6th, we shall
 have - - - - - $T = 177$
 Putting 177 for T in the 7th, we shall
 have - - - - - $S = 489$

Putting 489 for S in the 8th, we shall

$$\text{have } - - - - F \times G \times H = 666$$

In the last place, putting 666 for

$F \times G \times H$ in the 9th, we shall

$$\text{have } - - A \times B \times C = 472017 - \frac{9}{1125}$$

As the number 666 found as the value of the product $F \times G \times H$ of the pinions is composed of these four factors 2, 3, 3, 37, reducible to the following three, 3, 6, 37, which may be the numbers of the leaves of the three pinions; and as the number 472017, found as the product of the wheels, neglecting the negative fraction $-\frac{9}{1125}$, is composed of these factors 3, 7, 7, 13, 13, 19, which may be divided into these three bands (3, 19,) (7, 13,) (7, 13,) and reduced to these three factors, 57, 91, 91, which may be the numbers of the teeth of the three wheels, it is proved that the problem is solved.

It is to be remarked, that the negative fraction, $-\frac{9}{1125}$, neglected in the product of the wheels, and by which this product is rendered greater than it ought to be, in order to cause the wheel A to make a revolution in 29 days 12^h 44' 3" 12", will not occasion in the time of the revolution of that wheel an error of more than 2" $\frac{22}{37}$. For if we seek for the number of revolutions which the pinion H will make during a revolution of the wheel A, dividing the product 472017 of the wheels, by the product 666 of the

pinions, it will be found that this pinion H, which performs a revolution in an hour, will make 708 revolutions, which correspond to 708 hours, or to 29 days 12 hours, and there will remain 489 revolutions, or 489 hours, which being divided by 666 will give $44' 3'' 14'' \frac{22}{37}$. The time therefore, which the wheel A will employ to perform a revolution, will be 29 days 12 hours $44' 3'' 14'' \frac{22}{37}$; consequently will exceed the proposed time only by $2'' \frac{22}{37}$.

APPENDIX.

THE preceding investigations and demonstrations of M. Camus being the fullest, the clearest, and the best that have been published, on the principles according to which the teeth of wheels ought to be formed, the editor has deemed it useful to give the work entire, as extracted from M. Camus's "*Cours de Mathematique*," without interfering with the author's chain of reasoning by the insertion of notes, or of references to other authors.

The young engineer, millwright, clock, watch, and chronometer maker, and others, concerned with wheel work, who will diligently and carefully go through these investigations, will thenceforward have reason to rejoice at having acquired a correct feeling of the nature of the accuracy which is requisite, in order to insure the most beneficial and durable action of wheel work of every kind and magnitude.

From no other author would the student obtain so luminous and so critical a view of the requirements of perfect workmanship. But having once mastered Camus, and having obtained from his elegant demonstrations, a clear view of the nature and value of the epicycloidal curve in one wheel or pinion, acting on a radial line in another wheel or

pinion engaged with it, the searcher after accurate principles will be prepared for pursuing his inquiries into the nature and quality of other curves recommended for the teeth of wheels.

A controversy having subsisted now for thirty years, among many of our first rate scientific as well as practical men, on the question whether the diameter of the generating circle of the epicycloid, should be equal to the diameter, or, to the radius, of the opposite wheel or pinion; it becomes the duty of the editor to place the subject in dispute fairly before the scientific world, in order that the real truth of the matter may be clearly seen.

It may be well to commence with the following paper, prefixed to the first edition of this work. Its errors will subsequently be pointed out.

“ ADDITIONS TO THE WORK OF M. CAMUS.

“ *ALTHOUGH* the theory of M. Camus, explained in the succeeding pages, be strictly correct; yet as he has not given the generation of the epicycloid curve, nor its application, so as to render it familiar to practical mechanics,—to accomplish this desirable purpose, we are happy to avail ourselves of leave to make an extract from the new edition of Imison’s Elements of Science and Art, Vol. I., page 97; which will not only completely answer this valuable purpose, but also point out some further applications of that curve, as well as of the cycloid, which M. Camus has not touched upon, to other important uses in mechanics.

“ *To describe the Cycloid and Epicycloid: of use in shaping the Teeth of Wheels, &c.*

“ If a point or pencil *a* (fig. 8, plate 37), on the circumference of the circle B, proceeds along the plane *a* C in a right line, and at the same time revolves round its centre, it will describe a cycloid.

“ And, if the generating circle D (fig. 9), moves along the circumference of another circle E, and at the same time turns round its centre, the point *o* will describe an epicycloid.

“ *To apply the Cycloid and Epicycloid to the Teeth of Wheels, Pinions, Racks, &c. so as to cause them to act with the least possible wear, or loss of power, by friction.*

“ Having described the genesis of the cycloid and epicycloid, it becomes necessary to shew the manner of applying them, in practice, to the teeth of wheels, pinions, and racks; and to the cams, or lifting cogs, of forges, mills for bruising ore, pounding gunpowder, beating flax, hemp, &c. so as to cause them to act, with the least possible loss of power, by *friction*; and first, of the epicycloid.

“ Fig. 1 (see plate 37) represents portions of a wheel and pinion: A B, and C D, are the pitch-lines, or primitive diameters, as they are likewise termed; those parts of the teeth contained between the pitch-lines and the rims of the wheel and pinion, are to be made radii, or shaped to lines drawn from the divisions in the pitch-lines to the centres of the wheel and pinion; the curved

parts above the pitch-lines, reaching to the ends of the teeth, must be portions of epicycloids; in order to produce which, let two segments or portions of circles, equal to the radii of the pitch-lines, be drawn upon a smooth oaken or other plank, not less than half an inch in thickness, and let it be sawn or otherwise exactly shaped to those curves; see figs. 2 and 3; the first of which, being of the same curvature with the pitch-line of the pinion C D, and the second, the same sweep as that of the wheel A B, a hole must then be bored obliquely in each, commencing a quarter of an inch from the edge on one side, and terminating in the edge of the opposite side; into each of which holes a nail, &c. must be driven, until the points project a little below the holes, as at E E; these points must then be filed, so as to leave them exactly in the peripheries of the circles, just long enough to make an impression upon any plane surface placed beneath them, and must be rounded and made conical, so as to trace a smooth even line; then, after having rubbed the sides, or circular edges of the segments, with powdered resin, fix the segment (fig. 2) fast upon the pitch-line of the pinion; and apply the tracing point in the other segment (fig. 3) successively to all the divisions of the teeth in the said pitch-line, and pressing its edge close to the edge of the fixed segment, cause it to roll or revolve about it, without slipping, one way or the other, until it shall have described the curves proper for all the teeth of the pinion; then, taking off the small segment from the pinion, fasten the

larger one upon the pitch-line of the wheel; and proceed to describe the curves of the teeth of the wheel, with the tracing point in the small segment, exactly in the same manner as those of the pinion.

“The teeth in bevel geer, should also be made partly radii and partly epicycloidal.

“We shall next proceed to explain the method of applying the epicycloid to the lifting cogs or cams, of forge hammers, and other similar purposes, where both the moving bodies describe arcs of circles: in this case, as only one tooth, cog, or cam, acts at a time, we need only form two segments of circles; one corresponding with the radius of the mill shaft, or the place where the cog begins to act upon the hammer tail, as *CD* (fig. 4), and the other equal to the distance from the axis of the hammer to the aforesaid radius, as *AB*; then fixing the segment *CD*, in the manner before mentioned, upon a circle of the same radius, drawn upon any fit plane surface, we must furnish the other segment, *AB*, with a tracing point, and proceed as before to describe the curves proper for the lifting cogs: that part of the hammer tail upon which they act, requiring only to be made flat, and placed in a line drawn through both axes.

“Fig. 5, represents portions of a rack and pinion: *CD*, the primitive diameter, or pitch-line of the pinion; and *AB*, the pitch-line of the rack; the sides of the teeth in the pinion, from the pitch-line to their bottoms, are to be made radii, as in fig. 1; but the sides of the teeth in the rack, below the pitch-line, must be drawn at right-angles to the

pitch-line: the curved parts of the teeth in the pinion, and rack likewise, are to be made *cycloidal*, by forming a circular segment, corresponding with the radius of the pitch-line of the pinion; and a straight-edge or ruler, both being furnished with tracing-points in their edges; then, fixing the circular segment fast upon the pitch-line of the pinion, proceed to describe all the curved parts of its teeth, by placing the tracing-point in the edge of the straight ruler, successively in all the divisions in the pitch-line of the pinion, and rolling it either one way or the other upon the circular segment, without slipping; then, fixing the straight-edge fast upon the primitive or pitch-line of the rack, take off the circular segment from the pinion, and placing its tracing-point in the divisions made in the pitch-line of the teeth of the rack, roll it upon the straight-edge, either one way or the other, as before directed, until all the curves of the rack teeth are also traced.

“ Fig. 6, represents portions of a stamper of a mill for bruising ore, pounding gunpowder, beating hemp, &c. and of its shaft with lifting-cogs: A B, is a line corresponding with that part of the arm of the stamper upon which the lifting-cogs first act; C D, is the pitch-line of the axis, or the bottom of the curves of the lifting-cogs: in this case we need not be at the trouble of making segments; but describing a portion of a circle of the radius of the said pitch-line, upon any plane surface of wood, we drive a number of small nails, or tacks, into the said circular arc, leaving them standing half an

inch above the surface of the wood; then fixing a thread to the endmost nail, we make a loop at its other extremity, in which we place a tracing-point, or pencil, E; and keeping the thread stretched tight, cause it to form tangents to the circular arc CD; and thus the tracer will describe a curved line, being a portion of a cycloid, upon the plane surface of wood; which curved line is the proper form for the lifting-cogs of the mill-shaft; the arm of the stamper should be made flat at the part where the lifting-cogs act upon it, and should be placed in a line pointing to the centre of the mill-shaft, at the time the cog first comes into contact with it.

“ To form a Templet, or Pattern Tooth, to facilitate the Application of the Cycloid and Epicycloid, to the Teeth of Wheels, Pinions, &c.

“ As, however, it would in all cases be tedious, and in some nearly impracticable, to generate these lines and curves upon every tooth in a wheel, pinion, rack, &c.; we shall describe an easy mode of forming a templet, or pattern tooth, and the manner of applying it with facility, not only to the large teeth of wheels and pinions in mill-work, but also to the teeth of the smaller wheels, &c. employed in cotton works, clocks, watches, &c.

“ In order to which, having determined the radii of the pitch-lines, and made segments, corresponding thereto; having likewise determined the height and the depth of the teeth, and divided the pitch-lines into teeth and spaces, as before: then, for

wheels and pinions, instead of applying the segments immediately upon the wheels or pinions themselves, we take a plate of brass or other proper metal, *a, a*, (fig. 7); and fasten it (by means of pins, driven through holes made in its corners) upon any plane surface of wood; we then describe upon it, by means of compasses or beam-compasses, the lines corresponding with the primitive diameter or pitch-line, and tops and bottoms of the teeth in the wheel or pinion; and fixing the correspondent segment fast upon its pitch-line, with the point fixed in the other segment, describe that portion of the epicycloid which reaches from the pitch-line to the tops of the teeth; then, after having taken off the fixed segment, draw a radius line from the commencement of the curve in the pitch-line, to the bottoms of the teeth; and taking the metal plate off from the plane surface, accurately file or shape one edge of it from *b* to *b*; to these lines so drawn, and likewise shape its upper and lower edges to the circular arcs described upon it; the extra portion from *c* to *c*, may likewise be removed; then, taking a piece of wood (or in case of small works, metal), of a proper thickness and breadth, and long enough to extend over at least two of the teeth, describe upon it a circular arc, *d, d*, exactly equal in radius to the tops of the teeth, and then slitting one end of it from *b* to *d*, fix into that slit the metal plate before described, by that part of it which extends above the line *b, d*; observing that it be so placed in the slit, as exactly to correspond with its situation when generated;

that is to say, that the radius line of the templet, may point exactly to the centre of the circular arc d, d , of the piece of wood thus slit; and the similar arc, b, d , of the templet, be in contact with that arc; it must then be fastened in that position, by drilling holes through both pieces, and rivetting them together, so as to leave a projecting shoulder on each side of the templet, as shewn in fig. 10, then, having turned the tops of the teeth to their proper diameter, we have only to apply the proper templet to each division in their primitive or pitch-lines, and, resting at the same time the shoulder of it upon the tops of the teeth, draw the exact form of each tooth, by two operations (changing the side of the templet alternately), upon each of its ends; and afterwards shape its sides accordingly.

“ In the case of racks, the same process will take place; excepting only, that a straight-edge or ruler, must be fastened upon the primitive or pitch-line drawn upon the metal plate; when that portion of the cycloid must be generated (by means of a point, fixed in the circular segment corresponding with the pitch-line of the pinion which is to work in the rack), reaching from the pitch-line to the tops of the teeth; which done, the ruler must be taken off, and a line be drawn at right angles from the pitch-line, to the bottoms of the teeth; then, after shaping the edge of the metal plate to the said curve and right-line, it must be fitted into a slit, made in a straight-edge or ruler of a proper thickness, to leave a shoulder on each side of it; so as when applied upon the tops of the

teeth in the rack, its primitive line may correspond with the primitive or pitch-line of the rack teeth; by which means, the shape of the teeth may be traced upon their ends (by two operations), in the same manner as the teeth of wheels and pinions."

" Since these sheets were printed, a new edition of 'Ferguson's Lectures on select Subjects' has appeared, with additions by David Brewster, A.M. The latter treating on the formation of the teeth of wheels, &c. says, page 224, ' Thus have we endeavoured to lay before our readers all the information which we have upon this important subject; and we trust it will be candidly received, as it is the only essay on the subject which has appeared in our language;' and in a note he adds: ' In a book intitled, Imison's Elements of Science and Art, which professes to be a second edition of Imison's School of Arts, there are some practical directions for the formation of the teeth of wheels, but they are so defective in principle that they cannot be trusted. The author seems merely to have heard that the acting faces should be epicycloidal, but to have been totally ignorant whether the epicycloids should be exterior or interior, and what should be their bases and generating circles. The directions which this author gives for forming the teeth of a rack, and the lifting-cogs or cams of forge hammers, are equally destitute of scientific principle.'

" We may, however, remark here, that Mr. Brewster's is not the first essay on the subject

which has appeared in our language. A work in English on Mechanic Powers, by Mandey, was printed so long since as the year 1702, at the end of which he gives as an Appendix, an Essay on Epicycloids, and their Use in Mechanics, which he says was lately published in France by an able mathematician, and which in fact contains the principal part of the theory which Mr. B. now republishes! His additions are by no means applicable to our present improved practice; for it is a fact, that the epicycloidal faces of the teeth of wheels and pinions ought not to act upon each other, but reciprocally upon those parts which are made radii, to produce their most beneficial effects. None of the examples given by Mr. B., however, possess these advantages. We may remark farther, that the principles recommended by the author whom Mr. B. has attacked, are not only demonstrably correct, but have been found so in practice in mills upon a very large scale, the wheel-works of which have been in use for more than seven years, without requiring any repairs. The alleged ignorance imputed to the author of the paper in Imison's Elements, respecting 'whether the epicycloids should be exterior or interior,' is misapplied, for in all the examples he has given, there is no occasion of employing the interior epicycloid at all; but in regard to their bases, generating circles, and the manner of applying them to use, we think he has given very explicit information; and we may add, that his application of the epicycloid to forming the lifting cogs or cams of forge hammers, and of the

cycloid to the teeth of a rack and pinion, will be found equally correct and useful in practice."

The edition of Imison alluded to, was published in London in 1803. The first edition of the English translation of Camus appeared in 1806. The quotation from Ferguson is from the first edition of Ferguson's Lectures, edited by Dr., now Sir David Brewster. In the second edition of which, published at Edinburgh, in 1806, a second note is appended, as follows.

"The preceding note which was published in the first edition of this work, has called forth a reply from the author of the article in Imison's Elements, on which I had animadverted.

"This reply was published in a translation of one of Camus's Essays on the Teeth of Wheels, and was written by a Mr. Thomas Gill, in London. This gentleman insists, that the rules which he has given in Imison's Elements are correct, because they have been found to answer in practice; though it is demonstrable, and evident to every person who understands the subject, that the generating circles with which he describes his epicycloids, are *twice as large* as they ought to be. The same gentleman has thought proper to say, that the preceding article on the teeth of wheels is defective, in *not* containing that method of forming the teeth in which the acting faces are partly radii and partly epicycloids; while *this very method* is not only *given*, but *recommended*, to the notice of the practical mechanic! (see page 223, line 11 from bottom.) I

shall forbear making any animadversions on this new mode of literary assault. I willingly commit the subject to the judgment of every intelligent reader."

The passage referred to at page 223, is this, "As it would be extremely troublesome, however, to give the double curvature to the acting faces of the teeth, it will be proper to use a generating circle, whose diameter is equal to the radius of the wheel BC , for describing the interior epicycloid eh , and the exterior one bc , and a generating circle, whose diameter is equal to AC , the radius of the pinion for describing the interior epicycloid ba , and the exterior one ed . In this case the two interior epicycloids eh , ba , will be straight lines, tending to the centers B and A , and the labor of the mechanic will by this means be greatly abridged."

It is unnecessary to copy the engraving to which these letters of reference relate, as the demonstrations of *M. Camus* given above in the 6th Corollary (542), as deduced from the preceding numbers, commencing with 536, is so complete and satisfactory, that any one who will attentively study that portion of the work, and refer to the figures 178, 179, 180, 181, 182, and 183, plate 26, will see, *that the diameter of the generating circle of the epicycloid, must be equal to the RADIUS, and not to the diameter of the opposite WHEEL or PINION.*

When, instead of the teeth of a pinion, the rungs of a lantern are treated of, and considered as of infinitely small dimensions, then, and then only, the

generating circle of the epicycloid is defined to be *equal to the DIAMETER, and not to the radius of the LANTERN*; as is clearly shewn by the 7th Corollary (543). And here appears to be the origin of the erroneous view of the editor of Imison's *Elements*; he has not distinguished between the *epicycloid* acting against a *radial line*, and *that* acting against a *point*: the radial line in the *wheel* or *pinion*, demanding an epicycloid derived from the *radius*, while the *point* in the *lantern* requires an epicycloid derived from the *diameter*.

That the *wheel* or *pinion* requires the tooth of the driving wheel or pinion to be an epicycloid generated by a circle equal to the *radius* of the *wheel*, or *pinion*, is again shewn in the second solution (548), where these words occur, "the generating circle of which Y, *has for diameter, the radius AB of the pinion,*" referring to fig. 171, where the generating circle Y is shewn by dotted lines, to be half the diameter of the primitive circle of the pinion.

And in the third part of the same solution (548), these words are found, "the generating circle of which V, *has for diameter, the radius AF of the wheel,*" and this generating circle V is represented by dotted lines also in fig. 171.

There is therefore, no obscurity in the language of M. Camus on this subject, and it would be superfluous to quote other passages to the same purport, from his descriptions and definitions of the modes of forming the teeth of bevil wheels, pinions, and lanterns, where he demonstrates that the same

laws govern the genesis of the spherical epicycloid. (See 557 to 570.)

Although the above proofs must be sufficient for those who will go into the subject with the attention it deserves, yet as the false notion has obtained an extensive acquiescence on the part of many of our first-rate engine manufacturers, some of whom are pouring into the market multitudes of cast iron wheels and pinions of various magnitudes, for cotton and other machinery, with teeth formed from the epicycloid of the diameter, instead of the radius of the opposite wheel, or of the opposite pinion; the following extracts from Rees's Cyclopædia (article "Clock movement," said to have been written by Mr. Thomas Reid, an eminent clock maker of Edinburgh), are given in corroboration of the views before elicited, and in the hope of awakening those manufacturers to a sense of the injuries which they are occasioning to their customers, by supplying them with wheelwork that must wear out in a few years, instead of lasting the greater part of a century, which many of the wheels would do, were the teeth formed on true principles.

"Camus in his 'Cours de Mathématique,' liv. 10 and 11, has investigated the epicycloid as it forms a rule for the formation of teeth in wheelwork, which portion of the work has lately been translated into English, but the translator has added some practical directions respecting the shape of a tooth, taken from Imison's Elements of Science and Art, the principles of which we think it necessary to correct; at the same time that we

avail ourselves of the elucidation of our subject, which Camus's masterly treatment of it affords.'"

* * * * *

"The translator of a part of Camus, and the editor of Imison's Elements of Science and Art, have positively, though erroneously, asserted, that the generating circle should, in all cases of wheels and pinions, be equal to the fellow of the wheel on which the curve is to be described, in which opinion some very respectable mechanics agree; but others on the contrary, assert, with equal confidence and more truth, that the said generating circle should have its diameter equal to only one half of the diameter of the said fellow. (See Camus, Dr. Young's Syllabus, and Brewster's edition of Ferguson's Select Exercises, &c.)

"A careful examination of Camus's demonstrations would of itself have reconciled the disagreeing parties, which we trust a due attention to our elucidation, by means of the tracer and radial lever will not fail to effect. The fact is, that where pins like our tracers or spindles, are used for teeth in any wheel or lantern, as is frequently the case in large works, the generating circle must be equal in diameter to the diameter of the acting wheel or lantern which it represents, in order to trace the epicycloidal teeth of its fellow*; but in clock movements, and in all other instances in wheelwork,

* It should here be remembered that in this case the epicycloidal tooth must be first formed, as if working on a rung of infinitely small diameter, and then cut away to suit a rung of the given finite diameter; as clearly explained above by M. Camus. (545, 546.)

where both the wheels and pinions have the epicycloidal formation, the generating circle must be only one half in diameter, to what is required when lanterns are used, for in this case, which is most frequent, the interior and exterior epicycloids impel each other alternately, the former being a portion of a radial lever, and the latter a portion of the epicycloidal curve."

* * * * *

"Olaus Roemer, the celebrated astronomer and mechanist of Denmark, according to Wolfius and Leibnitz, was the first who pointed out the utility of the epicycloidal curve, when applied to delineate the shape of a tooth; but De la Hire took up the subject after him, and demonstrated that if a tooth of either a wheel or pinion be formed by portions of an exterior epicycloid, described by a generating circle of any diameter whatever, the tooth of its fellow will be properly formed, by portions of an interior epicycloid, described by the same generating circle; which curious circumstance allows of an infinite variety in the two corresponding curves that form the teeth of the wheel and pinion, if they were practicable."

The epicycloidal curves are applicable to practice, only in proportion as they approximate to that generated by a circle, the diameter of which is equal to the radius of the opposite wheel or pinion.

The student, however, will be well rewarded for his trouble in going through the investigations of M. De la Hire, in the original, published in Paris

in 1694, or in the translation of a considerable part of them into English, by Mandey, published in London in 1696.

M. De la Hire takes a different method of investigation, but arrives at the same conclusion as M. Camus; but M. Camus's process of reasoning is more concise, elegant, and clear.

It would be tedious to multiply quotations to enforce a point already so strongly proved. Should, however, any person have doubts still remaining, he would do well to pursue the inquiry, by referring to Dr. Thomas Young's *Philosophy* (published in London in 1807, 2 vols. 4to.), page 176 of vol. I., plate 15, and page 55 of vol. II.; Buchanan's *Essay on the Teeth of Wheels*, revised by Peter Nicholson (London, 1808, 8vo.), pages 15 to 35; Ferguson's *Lectures*, edited by Sir David Brewster (Edinburgh, 1806), pages 210 to 226; or indeed to any other author who has written on the teeth of wheels, except the editor of *Imison's Elements*; all besides him, having irrefutably proved that the epicycloidal part of a tooth, designed to act on another wheel or pinion, against a part of a tooth lying in a plane cutting the two axes, must, to insure smooth and durable action, be generated by a circle equal to the radius of the wheel or pinion, with which it is to be engaged; and not equal to the diameter, as contended for by the editor of *Imison's Elements*, and unfortunately acted on by many of our most eminent engine manufacturers, some of whom have confessed that they adopted the erroneous practice without investigation, from faith in

the very extensive mechanical knowledge possessed by the promulgator of the error.

The editor appreciates that knowledge so highly, that he has been in the habit, for more than thirty years, of designating his friend a walking encyclopædia; and has referred to him hundreds of times for information, as to what has been discovered and performed in numerous branches of science and art. His personal regard, therefore, would have prompted him to screen the editor of Imison's Elements from the exposure of his error, could he have forgotten the public duty which devolves upon him as editor of Camus; that duty imperiously calling on him to display the truth of the subject treated on, in the fullest and clearest manner, irrespective of the feelings or prejudices of any person whomsoever.

In order to address the understanding through the medium of the eye, for the information of those who either cannot or will not go into the mathematical investigation of this subject, two segments of the rims of spur wheels, the one of two feet, and the other of one foot radius, with epicycloidal teeth, are shewn in plate 38. The shaded teeth are of a proper length for smooth and durable action, either in wood or iron, requiring no play in the engagement, the entering corners of the teeth passing by each other without touching. Many millwrights, however, prefer the teeth somewhat longer, as represented by the dotted line *a b*; and some few, addicted to old fashions, make the teeth as long as is shewn by the round dotted line *c d*.

Our forefathers made the teeth long for the sake of having several in action at the same time, in order that each tooth should have to bear only a part of the strain; but experience has been gradually shortening the teeth of wheels; and the best mechanics now hold, that teeth longer than those represented by the shaded part of plates 38 and 39, are injurious.

It is much more advantageous to extend the bearing surfaces, by giving additional thickness to the wheels, and thereby additional breadth to the teeth; the division of the strain is thus effected without increasing the sliding of tooth upon tooth, which in long teeth is very considerable, but in short teeth is so small, that many good mechanics have expressed an opinion that there is no sliding; because, say they, the truly formed epicycloidal tooth rolls on the radial surface against which it acts; this is, however, an error, as will be obvious on inspecting the places of contact of the several teeth shewn in plate 38, where, if we suppose the segment $A B$ to be the driver, moving downwards and driving the segment $C D$, it is obvious, that the point of contact e of two teeth, when situated in the line of centers $x y$, will be at the place where the primitive circles $z 1, 2 3$, cut that line; but in descending the distance of a tooth and a space, the point of contact will be a little within the primitive circle of the segment $C D$, while the point g , which was in contact at e , will have receded from that primitive circle near f , by sliding four tenths of an inch. If the teeth were

elongated, as shewn by the dotted lines hbi , iak , and the motion continued the distance of another tooth and space, the point of contact i , would be a little farther within the primitive circle of the segment CD , but the point l , which was in contact at e , when in the line of centres, would, by moving the distance of two teeth and two spaces, have slid sixteen tenths of an inch, from that part of the primitive circle near i ; a quantity of sliding too destructive to be compensated for, by any advantage that could be derived from dividing the strain, by having two teeth always in contact instead of one. The quantity of sliding of any tooth on another, is always equal to the distance of the two primitive circles from each other, at the place nearest to the final contact of the two teeth.

If the other segment be considered as the driver, or both the segments be supposed to move upwards instead of downwards, the same results will become manifest, and it will be clearly seen, that the sliding of the tooth increases in a direct ratio with the angular distance of the point of contact from the line of centres.

Short teeth, therefore, have a great advantage over long ones on the score of sliding; and they have a great advantage too in respect of strength; and hence equal strength may be obtained from thinner teeth; and a greater number may be given to a wheel, whereby the strain may be beneficially divided, without occasioning the evil of excessive sliding, by which an injurious degree of friction

would be created, to be overcome by a continual waste of power.

The dotted lines mn , no , shew the elongation of a tooth of the segment CD , generated, as are the elongations of all the other teeth, by a circle equal to the radius of the opposite segment.

The dotted lines between and below the roots of the teeth, represent the necessary deepening of the spaces to allow the elongations free play. The dotted circular lines $p q$, shew that it is not necessary to weaken the tooth, by making the space angular at the bottom.

It is obvious on inspection, that the curves mn , no , hi , ik , are of the proper figure for acting on the radial lines, constituting the sides of the spaces of the opposite segments. Now these curves are accurately generated by circles, the diameters of which are equal to the radii of the primitive circles of the opposite segments; and are in strict accordance with the demonstrations of M. Camus.

The curve contended for by the editor of Imison's Elements, is shewn by the dotted lines mr , ro , which are generated by a circle equal in diameter with the diameter of the primitive circle of the opposite segment. It is clear from inspection, that a tooth thus bounded, could not act, except the sides of the space were made of a different figure from the line of radius. In fact, the part of the tooth within the primitive circle, would have to be cut away, less or more, according to the length of the tooth; thus, if the tooth were of the length represented by the shaded part, an inden-

tation should be made in the side of the tooth, equal to that shewn by the short curved dotted line st ; if the tooth were of the length indicated by the dotted line ab , the indentation would have to be longer and deeper, as shewn by the curved dotted line su ; and if the tooth were of the length shewn by the dotted lines mr , ro , then the indentation ought to be as long and deep as that shewn by the dotted line iv .

If these indentations are not made in the wheel by the millwright, the falsely formed teeth, will, in the course of working, excavate such indentations for themselves: hence we see too generally in old wheels, the teeth worn away into deep hollows within the primitive circles, while the points of the teeth have retained nearly their original false figure.

Many persons from observing this form of old teeth, have adopted the erroneous notion, that this is nature's form, and consequently must be the correct figure; they have, therefore, made the faces of their new teeth accurate copies of the old ones; merely taking care that the new teeth should be as strong as the old ones were, before they began to wear away.

Now if that part of the teeth of wheels, projecting beyond the primitive circles, be made truly epicycloidal at the first, and so accurately geared, that the primitive circles shall always cut the line of centres in the same place; and if that part of the teeth within the primitive circles be made

plane surfaces, lying in the direction of the radius, there appears to be no reason, why, in wearing, they should ever change their figure.

Mr. James White, however, in his *New Century of Inventions*, published at Manchester without date (suppose about 1820), quotes a memoir read by himself, before the Literary and Philosophical Society of Manchester, December, 1815, in which, after shewing the value of the epicycloidal curve for imparting equable motion from one wheel to another, he says (page 93), "I purposely omit other interesting circumstances in the application of this beautiful curve to rotatory motion; a curve by which I acknowledge that equable motions can be produced, when the teeth of the ordinary gearing are made in this manner. But here is the misfortune; besides the difficulty of executing teeth in the true theoretical form (which indeed is seldom attempted), this form cannot continue to exist; and hence it is, that the best, the most silent gearing becomes at last imperfect, noisy, and destructive of the machinery; and especially injurious to its more delicate operations."

Mr. White then attempts a theoretical proof of "the cause of this progressive deterioration," and concludes; "Thus it appears that independantly of the effects of percussion, the *end* of an epicycloidal tooth must wear out sooner than any part near its base (and if so, much more it may be supposed of a tooth of another form); and that when its form is thus changed, the advantage it gave

must cease, since nothing in the working of the wheel can afterwards restore the form, or remedy the growing evil."

Experience does not confirm Mr. White's theory, and his reasoning fails to convince the editor that there is any tendency in the epicycloidal tooth to wear its fellow unequally. Indeed he is convinced that there is no such tendency; and that all the irregular wearing away of teeth, is occasioned entirely by their original improper configuration.

The two curved lines mw , wo , are involutes of the primitive circle of the segment CD ; it is evident on inspection, that these curves would require much deeper indentations of the sides of the teeth within the primitive circles, than the curves mr , ro , and therefore would excavate such indentations for themselves in the course of working against teeth having radial planes at the base.

In this, as in all other malformations of a tooth, the wearing away has no tendency to repair the figure, but, like a crooked river in a level country, which always grows more crooked, except art interpose a barrier, so the indentations at the sides of the tooth will go on increasing in magnitude, until the tooth becomes too weak to resist the strain thrown upon it.

All the remarks on the wearing away of the radial plane, or internal epicycloid, apply, in an especial manner, when the teeth are made of wood, however hard; because the side of the grain is more easily abraded than the part which partakes

both of side and end grain, as is the case with the epicycloidal face of the teeth outside the primitive circle.

When metal teeth work together, the alteration of figure is less rapid, on account of the homogeneous nature of the material, and because there generally exists a small degree of compensation for the irregular form of the tooth, in the yielding afforded by the elasticity derived from the torsion of the shafts, whereby the shocks from the ill-formed teeth are rendered less severe than they would be, if the shafts possessed no elasticity.

These shocks, and the consequent friction and wearing away, are sometimes avoided, by making two rows of teeth in each wheel, the teeth in one row standing opposite the spaces in the other row; and sometimes three rows are employed, the teeth of each row being placed one third of the pitch behind or before the teeth of the adjoining row; and thus the evils arising from bad figure of tooth, are lessened, although not entirely avoided.

Before dismissing the consideration of the epicycloid, it will be proper to notice some of the other errors of the paper headed, "Additions to the work of M. Camus" (copied in this Appendix, page 134). It is stated that Camus "has not given the generation of the epicycloid curve." This is a mistake, since the definitions (536) and six subsequent corollaries are expressly devoted to the mode of generating that curve.

The application of "the epicycloid to the lifting cogs or cams of forge hammers" (page 137) is con-

trary to all sound mechanical principles; because a cam formed according to that curve, would set the hammer in motion at its full velocity at once, from a state of rest; and would require an enormous degree of power to overcome the *vis inertia* of the hammer. Whereas the face of the cam ought to be so formed as to commence lifting the hammer with a very moderate speed, and then follow it up with accelerated velocity, until it attains its greatest altitude.

It is said (page 138) that "the curved parts of the teeth in the pinion, and rack likewise, are to be made *cycloidal*." The curve generated by the circle rolling upon the straight line, will be a cycloid; but since it is generated by a circle equal in diameter to the diameter of the primitive circle of the pinion, it is a false curve for the purpose of forming the extremities of the teeth of the rack. The diameter of the generating circle ought to be equal to the radius of the primitive circle of the pinion; for similar reasons to those abundantly given above in respect of wheels and pinions.

The term cycloid is a misnomer, as applied to the curve generated by a straight line upon a circular base, as in the teeth of the pinion, fig. 5: that curve is the *involute*, which will be treated of below.

The same errors pervade the directions for lifting the stamper (fig. 6). 1st. The curve denominated the cycloid, is the involute, but represented as being generated by a thread, instead of a "straight edge or ruler:" now both methods pro-

duce exactly the same curve. 2ndly. The involute is highly improper for a cam to lift a stamper, for the reasons given against the epicycloidal cam for lifting a forge hammer; the shocks in either case would be so tremendous as to shake the works to pieces in a short time.

In page 143 it is said, that "there is no occasion of employing the interior epicycloid at all." The editor of Imison's Elements seems not to be aware that Sir David Brewster uses the term interior epicycloid to designate the radial line, which is a real internal epicycloid generated by a circle equal in diameter to the radius of the base.

Having performed the unpleasant duty of pointing out the errors of the above paper, as a warning to young engineers, millwrights, clockmakers, &c. the editor takes upon himself the pleasant office of recommending to the attention of the student, the excellent mechanical apparatus shewn at figures 2, 3, 7, and 10, and described in pages 136, 139, 140, &c. reminding him however that the curves of figures 2 and 3 are from radii twice as long as they ought to be.

OF THE INVOLUTE.

Since M. Camus has treated of no other curve than the epicycloid, it would appear that he considered it to supersede all others for the figure of the teeth of wheels and pinions. And the editor must candidly acknowledge, that he entertained the same opinion, until after the greater part of the foregoing sheets were printed off; but on critically

examining the properties of the involute with a view to the better explaining of its application to the formation of the teeth of wheels and pinions, the editor has discovered advantages which had before escaped his notice, owing, perhaps, to his prejudice in favour of the epicycloid, from having, during a long life, heard it extolled above all other curves; a prejudice strengthened too by the supremacy given to it by De la Hire, Dr. Robison, Sir David Brewster, Dr. Thomas Young, Mr. Thomas Reid, Mr. Buchannan, and many others; who have, indeed, described the involute as a curve by which equable motion *might* be communicated from wheel to wheel, but scarce any of whom have held it up as equally eligible with the epicycloid; and owing also to his perfect conviction, resulting from strict research, that a wheel and pinion, or two wheels, accurately formed according to the epicycloidal curve, would work with the least possible degree of friction, and with the greatest durability.

But the editor had not sufficiently adverted to the case where one wheel or pinion drives, at the same time, two or more wheels or pinions of different diameters, for which purpose the epicycloid is not perfectly applicable, because the form of the tooth of the driving wheel cannot be generated by a circle equal to the radius of more than one of the driven wheels or pinions. In considering this case, he found that the involute satisfies all the conditions of perfect figure, for wheels of any sizes, to work smoothly in wheels of any other sizes; although, perhaps, not equal to

the epicycloid for pinions of few leaves. The only objection to the involute that occurred to some, was, that great inclination of the line of contact of the two teeth to the line of centres, must give a continual tendency in the driving wheel, to thrust the driven one to a greater distance from itself; and, consequently, to produce a constant pressure against the bearings of both axles.

This opinion was confirmed by the remarks of Dr. Thomas Young (Lectures on Natural Philosophy, Vol. I. page 177.) He says, "If the face of the teeth where they are in contact, is too much inclined to the radius, their mutual friction is not much affected, but a great pressure on their axes is produced, and this occasions a strain on the machinery, as well as an increase of friction on the axes."

Holding this view, it was not without surprise that the editor was informed by that extremely accurate workman, Mr. Joseph Clement, Engineer, of Prospect Place, Lambeth, that he had often laid two wheels, with teeth of the involute figure engaged together, on a work-bench, without any confinement of the axes, and that either of the wheels, on being turned around, would turn the other, without thrusting it away, or exhibiting the least tendency to increase the distance of the axes.

With the view of aiding in the developement of the cause of this fact, so contrary to the appearance, the editor constructed the sectors of two

wheels, each of two feet radius, and containing four teeth of the same curve as those of the segment G H (plate 39); but of the dimensions shewn by the dotted line *a b c d*; one of these sectors (designated No. 1) was mounted on a fixed axis, and the other (No. 2) on an axis so delicately hung, that a force, equal only to a few grains, would cause the sector, No. 2, to recede in a direct line from the fixed axis of No. 1. Thus prepared, the following experiments were made.

Experiment I.

The teeth of both sectors being engaged, their full depth of an inch and a half, No. 1 was moved forwards and backwards a great number of times, without exhibiting the least tendency to thrust No. 2 to a greater distance, notwithstanding the tangent to the surfaces of the teeth in contact formed an angle of nearly sixteen degrees with the line of centres. The points of contact of the teeth at the line of centres, were three quarters of an inch from the ends of the teeth.

Experiment II.

The teeth were engaged an inch and a quarter deep, consequently the ends of the teeth were a quarter of an inch free from the bottoms of the spaces; the tangent of contact made an angle of nearly seventeen degrees with the line of centres; and the point of contact at the line of centres, was five-eighths of an inch from the ends of the teeth. The sector No. 1 being repeatedly moved forwards

and backwards, sometimes caused No. 2 to approach, but never to recede.

In Experiment I., the approach could not take place, because the teeth were engaged their full depth.

Experiment III.

The teeth were engaged one inch deep, leaving half an inch between the ends of the teeth and the bottoms of the spaces. The angle of the tangent of contact with the line of centres, was eighteen degrees; the points of contact at the line of centres, half an inch from the ends of the teeth. On the sector No. 1 being moved frequently forwards and backwards, no motion of the axle of No. 2 appeared.

Experiment IV.

The teeth of the sectors were engaged three quarters of an inch deep, consequently the ends of the teeth were three quarters of an inch free from the bottoms of the spaces; the points of contact of the teeth at the line of centres, were three-eighths of an inch from the ends of the teeth; the angle of the tangent of contact with the line of centres, was nineteen degrees. The axle of sector No. 2 neither approached nor receded on numerous trials made by moving No. 1.

Experiment V.

The teeth were engaged half an inch deep; the point of contact was a quarter of an inch from the ends of the teeth, at the line of centres; the ends

of the teeth were one inch from the bottoms of the spaces; the tangent of contact formed an angle of full twenty degrees with the line of centres. In a great number of repetitions of this experiment, a slight receding of sector No. 2 sometimes appeared.

Experiment VI.

The teeth were engaged a quarter of an inch; the ends of the teeth, therefore, were one inch and a quarter from the bottoms of the spaces; and the points of contact one-eighth of an inch from the ends of the teeth, at the line of centres; the angle of the tangent of contact with the line of centres was rather more than twenty-one degrees.

In this experiment which was repeated very frequently, a tendency to recede appeared several times, but so slightly as to be of no practical importance; the quiescent state of the axle was much oftener manifest than the receding.

These experiments, tried with the most scrupulous attention to every circumstance that might affect the results, elicit this important fact, that the teeth of wheels, in which the tangent of the surfaces in contact make a less angle than twenty degrees with the line of centres, possess no tendency to cause a separation of their axes, consequently there can be no strain thrown upon the bearings by such an obliquity of the tooth.

The fact ascertained, the cause must be sought. Now the angle of inclination of the teeth must, according to the theory of inclined planes, have a

tendency to cause the driven tooth to recede from the driver, in the direction of the line of centres, with a force equal to the sine of the angle of inclination; there must, therefore, be a counteracting cause somewhere; a tendency to make the axes approach each other. There appears to be only one cause in operation that can possibly afford that counteraction, and that is, friction; the friction of the teeth upon each other, tending to drag, rather than to slide.

In these experiments, the friction may be supposed to be considerable, because the sectors were made of soft red cedar, a quarter of an inch thick, with the grain of the wood lying in the general direction of the length of the teeth. But in Mr. Clement's experiments of the wheels lying loosely on the work-bench, the teeth were all of metal; and yet in that case the counteracting attraction by friction, was "*equal, if not superior to the repulsion by the obliquity of tooth;*" of which fact there will be no doubt in the minds of those who are acquainted with Mr. Clement's character for veracity and experimental tact.

ON THE INVOLUTE TRACER.

A very simple instrument for drawing the involute with ease and accuracy, is shewn at fig. 1 (plate 40), where A represents a plan of the instrument, and B an end view; *a b* shews a straight piece of watch spring filed away at the edges, so as to leave two short teeth, or marking points (*c c*), projecting from the two edges of the watch spring;

at *a* is a screw, holding the spring in contact with the end of a templet formed according to a sector of a circle, equal to the base upon which the involute is intended to be generated; at *b* a bit of wire is put through and rivetted in the spring to form two knobs as a handle, by which the spring can be kept on the stretch, and moved laterally; *d e f* is the sector or templet, equal in thickness to the width of the spring.

In using this instrument, fasten the templet upon the side of the wheel, drawing board, or upon whatever surface the involute is to be drawn; the centre *f* coinciding with the axis of the wheel or its representative on the drawing board, or other surface; then, holding the knobs as a handle, keep the spring stretched tightly, so that it may remain a correct tangent, while it is made to approach the circle; and the marking point is made to leave a trace upon the surface over which it has passed; when the marking point arrives at the circle, the tracing left by the point will be a true involute.

Two teeth are left in the spring, so that it may be turned over to form the counter involute, for the other side of the tooth of the wheel.

For very small wheels, the thinnest watch-spring may be used, and if none be found thin enough, it can be filed thinner; for it is an essential circumstance to the formation of a true involute, that the spring, when left to itself, shall be quite straight, and shall recover that straightness after having been bent into contact with the circle.

For large wheels a straightened clock-spring

will be found very convenient for the purpose; and to save the trouble of filing away the width of the spring, to leave two teeth, a small part of the spring may be softened by a pair of red-hot tongs, and a point be raised up from the line of the edge, on each side, by a cut with a sharp chisel, as shewn at fig. 2.

ON DRAWING THE OUTLINES OF A PAIR OF
WHEELS WITH INVOLUTE TEETH.

To proceed in tracing the outlines of a pair of wheels with teeth, formed according to the involute curve; draw the line of centres, ab (fig. 3), and divide it at c , into two parts, proportionate to the intended velocities of the two wheels; draw a line, de , cutting the line of centres at c , making with it an angle, deviating not more than twenty degrees from a right angle; draw from the centre a , a circle A, that shall have the line de for a tangent; and draw from the centre b , a circle B, that shall have the other end of the same line for a tangent; the distance between the two circles will be the proper length of the teeth, from which however a little should be deducted to allow of free action.

These two circles also will be the bases from which the involutes are to be respectively generated, for forming the boundaries of teeth proper for communicating equable motion from either wheel to the other, without possessing any tendency to press the shafts or axles outwardly against the bearings, which tendency would exist, if the angle of the common tangent of the two circles

deviated much more than twenty degrees from a right angle with the line of centres.

Having provided two involute tracers, each having a templet corresponding respectively with sectors of the two circles, apply the centres (*f*, fig. 1) upon the centre of one of the circles, place the templet on that side of the line of centres where the tangent meets its circle, and adjust it, until the tracing point stands over the intersection of the common tangent and the line of centres; then, holding the templet firmly in its place, and stretching the spring tightly with the hand, cause the tracing point to describe a line from circle to circle; this line will be an involute, proper for the boundary of a tooth of a wheel having the same radius as the templet by which it was generated.

Proceed in the same manner with the tracer of the other circle, and there will be found the outline of a tooth proper for the second wheel.

Thus will the boundary of one side of a tooth in each circle be defined; and the two involutes will be in contact with each other at the line of centres; the tangent of that contact forming a right angle with the common tangent of the two circles; and, consequently, making an angle of twenty degrees with the line of centres.

That two teeth so formed would communicate equable motion from one wheel to the other, is demonstrated according to the theorem (521), and Corollaries (522 and 525).

Commencing at the roots of these two involutes, where they meet the respective circles, divide the

circles into the proper numbers of teeth; each division comprehending the width of a tooth and a space (denominated the pitch of the teeth); draw, from all the points of division, involutes having the same inclination from the radii of the circles as the first pair of involutes; that is to say, if the first pair leaned to the right of the radius as viewed from the centre, all the involutes must lean to the right, and *vice versá*: thus will be drawn the right or left boundaries of all the teeth. Fig. 3 represents them all drawn to the right, forming the left boundary of the teeth.

It is to be remarked, that when the teeth of both wheels are of the same material, they ought, for the sake of equal strength, to be made of the same thickness at the base; but when the teeth of one wheel is made of a much stronger material than the teeth of the other, as in the case of cast iron teeth working in wooden ones, the bases of the wooden teeth should be much thicker than the bases of the iron ones.

If the teeth of both wheels are to be of equal thickness at the base, that part of the common tangent lying between the involute, which cuts the line of centres and the involute next below it, should be bisected in the middle, and an involute bending to the left, be drawn through the point of bisection to the base circle of each wheel: the second sides of two teeth will thus be drawn, and their roots be so nearly equal, that a very slight correction only will be necessary; the correction depending on the proportionate diameters of the wheels.

When the teeth of one wheel are to be thicker than those of the other, the part of the common tangent must be unequally bisected, in proportion to the required difference.

The base of one tooth in each wheel being found, the distance may be taken in a pair of compasses, and marked off from the base of each of the involutes already shewn in fig. 3: from each point thus obtained, an involute leaning to the left is to be drawn, and the work will appear as in fig. 4.

Finally, the distance from the centre of the one circle to the circumference of the other, is to be taken; then shortened a little, to allow of free play between the tip of the tooth and the bottom of the space; with this shortened distance for radius, mark the end boundaries of all the teeth, and the appearance will be similar to fig. 5.

The sides of the teeth might all be drawn by the involute tracer, but the work would be facilitated by forming accurately one pattern tooth for each wheel, at the end of a sector of a circle, turning on the centre of the wheel; such a tooth and sector is represented at fig. 6; the notches at the side of the tooth are designed to allow the marking point to come freely to the base circle, when the marking point is held obliquely in the hand.

Plate 39 represents segments of a pair of wheels of one foot, and of two feet radius respectively; thus, twelve times the magnitude of (fig. 5, plate 40); the teeth drawn with great accuracy, are of the same proportionate figure, and the contact

of the teeth will be seen to be always in the common tangent.

E F, the segment of one foot radius.

G H, the segment of two feet radius.

a b c d, dotted lines, shewing the size of the tooth used in the experiments.

e f, the common tangent, generating all the involutes bending to the right.

g h, the common tangent, generating all the involutes bending to the left.

i k, the line of centres.

From this plate it is seen how beautifully teeth of this proportionate length and figure, clear each other, in entering into, and departing from contact, requiring no play in the engagement.

One important advantage is obvious, namely, that a greater number of teeth of equal strength may be given to a wheel by the involute, than by the epicycloid; because the space must be equal to the tooth in the case of the epicycloid, while not much more than half the space is required for an involute tooth of this length to enter, and even less than half when the tooth is made a little longer than those in plate 39; there will be more teeth engaged at the same time, and thus the strain will be divided; the sliding also will be diminished, and the rolling of tooth on tooth increased; nevertheless the sliding will exist to a much greater degree than is supposed by most writers on the subject; for to arrive at the distance of the pitch from the line of centres in plate 39, the slide is rather more than

two tenths of an inch; but it is nearly double that quantity in plate 38; the moving the distance of the pitch from the line of centres occasioning the sliding to be four tenths of an inch as before mentioned.

It will be very useful for the student to practise his eye, by frequently looking at the two plates, 38 and 39, and to exercise himself in drawing both kinds of curves, in various proportions and dimensions, thereby to acquire facility in judging of the probable durability of any wheelwork, which he may be called upon to inspect; for he may assure himself, on investigation, that any tooth which is thicker at the point in proportion to the base and length, than those represented in plate 38, as formed according to the epicycloid generated by a circle of half the diameter of the opposite wheel or pinion, will have a tendency to excavate a hollow for itself to work in, in the side of the opposite tooth within the primitive circle; and thus the teeth will wear one another out in a very short time, compared to the great durability they would have, if formed accurately by that curve; or by the involute shewn in plate 39.

It is the editor's opinion, that teeth accurately formed, either by the epicycloid or involute curve, will endure the wear of a century with less damage than teeth, as usually made, suffer in ten years.

Before dismissing the involute, it may be well to remark, that what has been said respecting that curve should be considered as a mere sketch, there appearing to be many very interesting points

in regard to its application, in the formation of the teeth of wheels, which require strict investigation and experiment.

It is the editor's intention to pursue the inquiry, and should he discover a clear theory, and systematic practice in the use of the involute, he shall feel himself bound to give his views to the public in a separate treatise. He thinks he perceives a wide field, but he is free to confess that his vision is as yet obscure. What he has given on the involute is more than was due from him, as editor of Camus, who treated only of the epicycloid, but the zeal of a new convert to any doctrine is not easily restrained.

BEVIL GEER.

In forming the teeth of bevil geer, the principles of which are clearly laid down by Camus (see 557 to 570, and plates 32 to 35 inclusive); it will be sufficient for practice that the figure of the teeth be drawn on the outer spherical surface of the wheels, R E S, fig. 196, 200, and 202; and of the pinion A B T, fig. 202; whether the curve assumed be the epicycloid, the involute, or any other configuration; and that the sides of the teeth be accurately formed, according to straight lines, all meeting together in the common point of intersection of the axes of the two shafts carrying the engaged wheels, or the engaged wheel and pinion; that common point of intersection is marked C, in all the figures from 195 to 204 inclusive.

PRESENT PRACTICE.

Before stating the present practice in forming the teeth of wheels, the editor takes much pleasure in acknowledging the very polite attention he has received from a considerable number of the principal manufacturers of machinery, in which toothed wheels are used; many of whom have permitted him to question their foremen, pattern makers, and workmen, and to inspect the means, instruments, and tools, used by them respectively.

Among the houses, especially entitled to his thanks for liberally affording him every facility in his inquiries, are the following:—

Messrs	Maudslay and Field, Engineers,	London
	Rennie and Co.	ditto ditto
	Donkin and Co.	ditto ditto
	Bramah and Co.	ditto ditto
	Seaward and Co.	ditto ditto
Mr.	Clement, Engineer,	ditto
	Topham,	ditto ditto
Messrs.	Sharp, Roberts, and Co.	ditto Manchester
	Guest, Lewis, and Co.	Dowlais Iron Works,
	Merthyr Tydvil	
	Troughton and Simms, Mathematical Instrument Makers,	London
	Dent and Arnold, Chronometer Makers,	London
Mr.	Vulliamy,	ditto London
	Saxton, Mechanician,	ditto
	Fayrer, Philosophical Instrument Maker,	London

A painful task now presents itself, which the

editor would gladly avoid, if he could do so without a dereliction of duty; namely, to declare that there is a lamentable deficiency of the knowledge of principles, and of correct practice, in a majority of those most respectable houses in forming the teeth of their wheel-work.

Some of the engineers and millwrights said, that they followed Camus, and formed their teeth from the epicycloid derived from the diameter of the opposite wheel; and that they were induced to do so, by the recommendation of the editor of Imison's Elements. It is clear, therefore, that they could not have read Camus with due attention, or they could not have imagined that they were working on his principles, while they were depending only on the false view given in the paper prefixed to Camus, already so much animadverted on.

One said, "We have no method but the rule of thumb;" another, "We thumb out the figure;" by both which expressions may be understood, that they left their workmen to take their own course.

Some set one point of a pair of compasses in the centre of a tooth, at the primitive circle, and with the other point describe a segment of a circle for the off side of the next tooth. At 4, 5, plate 38, are two dotted arcs of circles from the centres of the next teeth. Others set the point of the compasses at different distances from the centre of the tooth, nearer or farther off; also within or without the line of centres, each according to some inexplicable notion received from his grandfather, or picked up by chance. It is said inexplicable, because no tooth bounded at the sides

by segments of circles, can work together without such friction as will cause an unnecessary wearing away.

It is admitted, that with a certain number of teeth of a certain proportionate length as compared with the radii, there may be a segment of a circle drawn from some centre which would give "very near" a true figure to the tooth; but "very near" ought to be expunged from the vocabulary of Engineers and Millwrights; for that "very near" will depend on the chance of hitting the right centre and right radius, according to the diameter of the wheel, and the number of teeth; against which hitting, the odds are very great indeed.

Among the Mathematical Instrument Makers, Chronometer, Clock and Watch Makers, the answers to the inquiries, were, by some, "we have no rule but the eye in the formation of the teeth of our wheels;" by others, "we draw the tooth correctly on a large scale to assist the eye in judging of the figure of the small teeth;" by another, "in Lancashire they make the teeth of watch-wheels of what is called the bay leaf pattern; they are formed altogether by the eye of the workman; and they would stare at you for a simpleton, to hear you talk about the epicycloidal curve." Again, "the astronomical instrument makers, hold the bay leaf pattern to be too pointed a form for smooth action; they make the end of the tooth more rounding than the figure of the bay leaf."

It is curious to observe with what accuracy the practised eye will determine forms; it is not gene-

rally known, but it is a fact, that the dots marking the minutes on the enamelled dial plates of watches, are put on by hand with a camel's hair pencil guided only by the eye, they are done with great expedition, and rarely can an error in their distances be measured.

Such being the accuracy of the eye, how important it is, that these Lancashire bay leaf fanciers, should be furnished with pattern teeth of large dimensions cut accurately in metal or at least in card board; and that they should frequently study them, and compare their work with the patterns. These Lancashire workman are called bay-leaf fanciers, because they cannot be bay-leaf copiers; since it is notorious that there are not two bay-leaves of the same figure.

Mr. Saxton of Philadelphia, now in London, who is justly celebrated for his excessively acute feeling of the nature and value of accuracy in mechanism; and who is reputed not to be excelled by any man in Europe or America for exquisite nicety of workmanship; made in Philadelphia, an instrument for cutting the teeth of watch wheels, truly epicycloidal; or rather for curving them after they were cut down in the ordinary manner, with radial faces. The following, is his verbal description of this instrument.

The wheel to be rounded being put on a vertical arbor, another arbor ^{stands} parallel to the first, carrying, on a third but horizontal arbor, a steel wheel file cut on the plane side, which plane side lies in a vertical plane passing through the axis.

of its vertical arbor. On the arbor of the wheel to be rounded, is a circular plate, equal in diameter to the primitive circle of that wheel ; the edge of the plate is milled into teeth as fine as possible: this plate forms the base of the epicycloid. On the other vertical arbor is a similar plate, but equal in diameter to the radius of the primitive circle of the wheel to be engaged with that about to be rounded : this plate is the generating circle.

In working this instrument, the flat sided cutter is brought in contact with the side of the tooth to be rounded ; the axes of the two vertical arbors, the face of the cutter, and the line of the tooth, all lying in one vertical plane ; the cutter being set into rapid motion by a band, the generating circle is rolled around the base, and thus one side of the tooth is rounded in a truly epicycloidal curve of the required dimensions.

Upon this plan, epicycloidal teeth of any magnitude, might be cut with great expedition.

Such an instrument ought to be added to every Engineer's stock of tools.

The application of an engine of this kind in forming the teeth of chronometer wheels would be of very great importance. And scarce any pains that could be bestowed in perfecting the figure of the teeth of wheels for measuring time truly, would go unrewarded.

One of our most eminent watch makers, however, says, that the prices at which, even first rate watches are sold, will not warrant the care that must be bestowed on them, to insure perfect ac-

curacy in the figure of the teeth of all the wheels of a watch.

CONCLUSION.

Having given the admirable chain of reasoning of M. Camus entire, and unencumbered with notes or references, and followed it by the whole of the paper prefixed to the first edition, headed, "Additions to Camus," as extracted from Imison's Elements, the public are put into possession of that which has been loudly called for; namely, a second edition of Camus on the Teeth of Wheels.

But the widely extended mischief which those prefixed "additions" have inflicted upon the mechanical world, and the apathy with which many of the first mechanists in the country have regarded the figure of the teeth of wheels, rendered it expedient that the subject should be enlarged upon in a more popular manner, and the errors of that paper, and of practice, be clearly exposed.

The involute, which has heretofore received but slight notice, as applicable to the formation of the teeth of wheels, required a fuller exposure; and, indeed, still requires much greater research; but the public impatience for the appearance of the work, would not allow time for further investigation; nor would the amount prescribed by the booksellers, as the maximum selling price, enable the publisher to afford any more space for that inquiry.

Finally, let the young mechanist allow an old engineer to give him a few parting words of advice

derived from long observation and experience in wheel-work. Above all things, let him abhor the "rule of thumb;" and let him always be able to give a reason for his practice. Let him not imagine that a thing is right, because such and such great houses adopt it, for it often happens, that the foreman, who has the direction in this department, has no other qualification than that of being a good and careful workman, which he may be, and yet be totally unacquainted with the principles upon which he ought to proceed. He produces, perhaps, a passable result, because it was his good luck to copy a passably good practice in his youth.

Let *him*, however, who would go to work with an understanding of his subject, investigate for himself, and take nothing upon trust; but let him ascertain for himself, the truth of every proposition he admits, and not blindly follow the practice, or submit to the judgment, of others.

THE END.

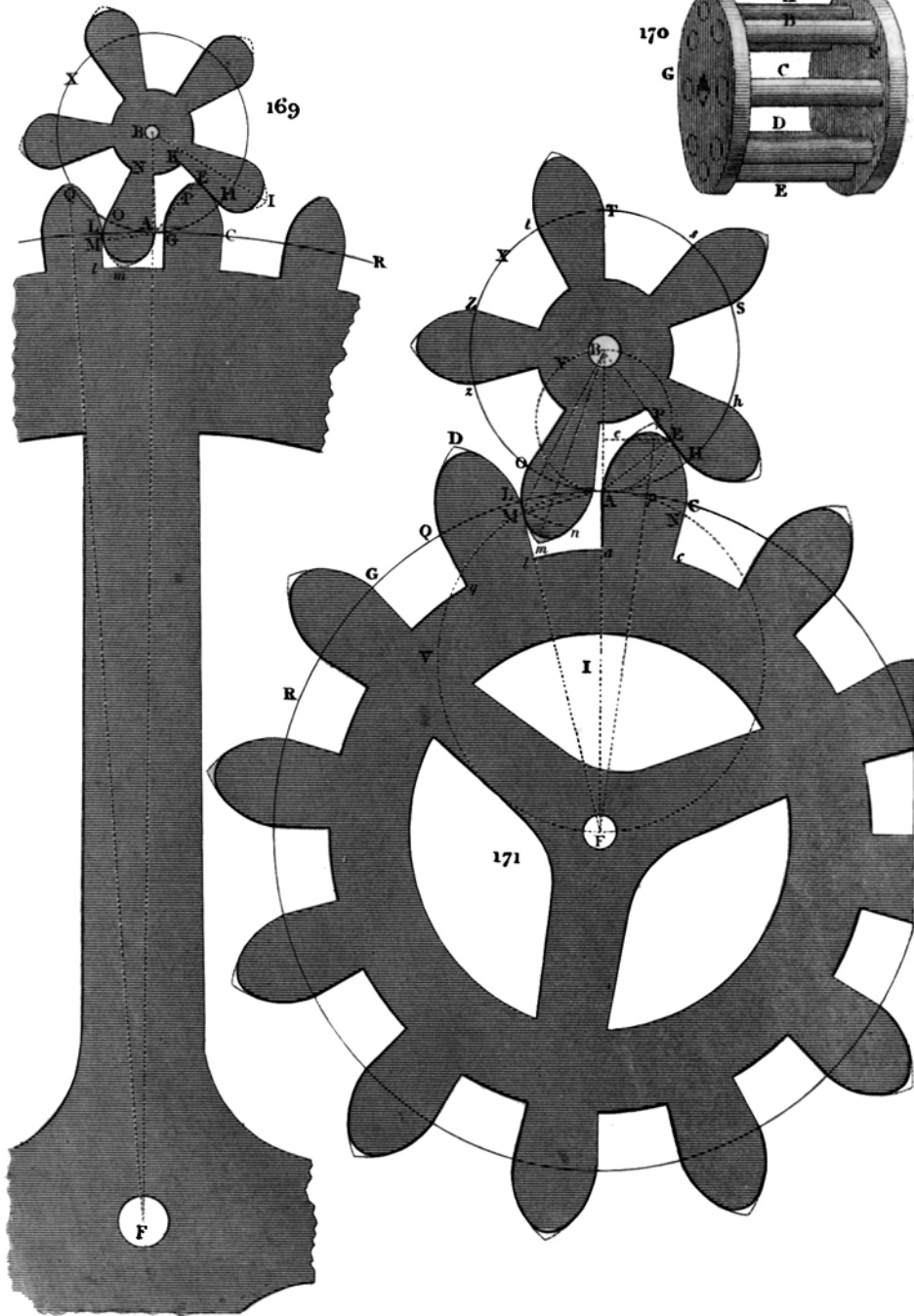

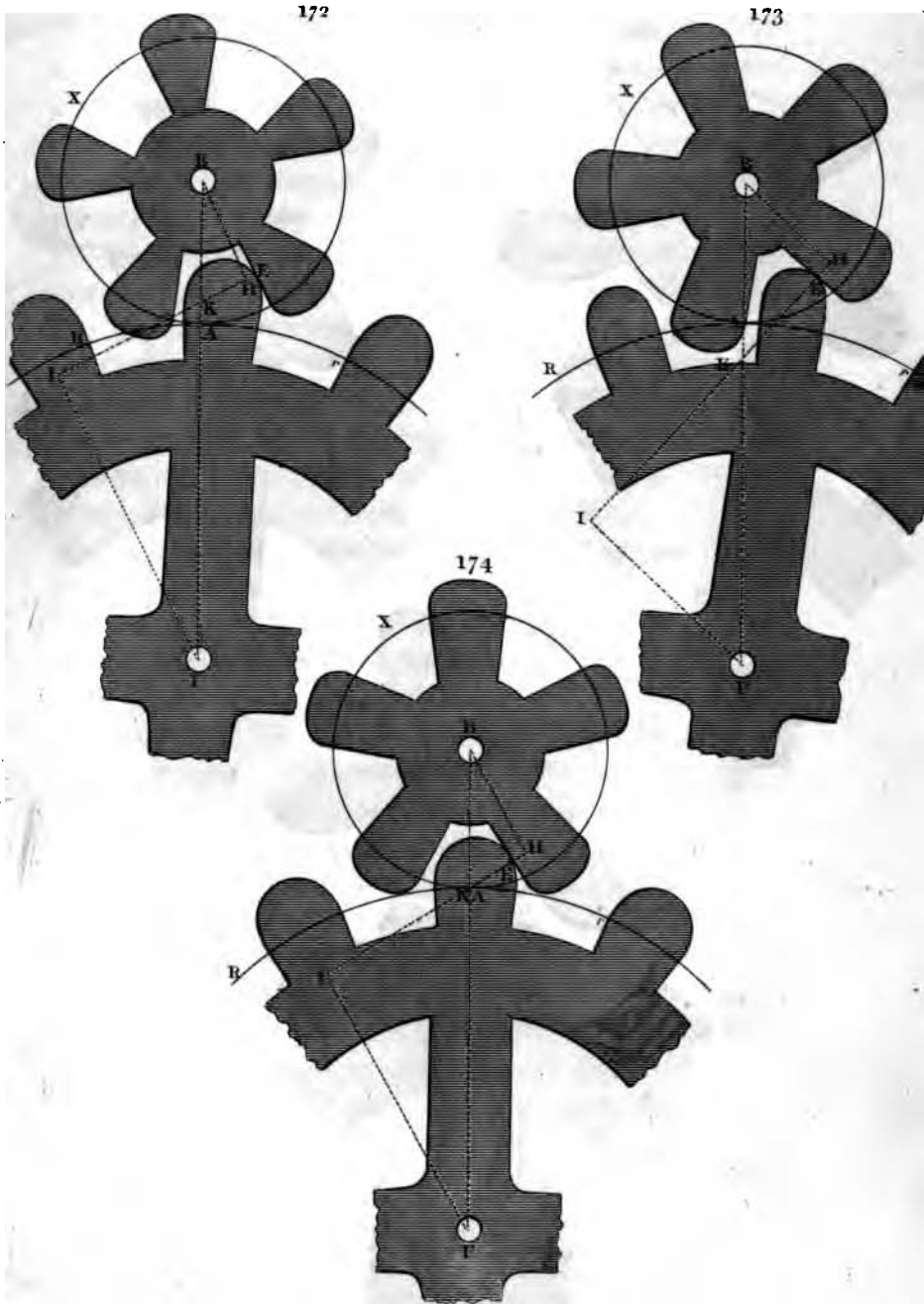

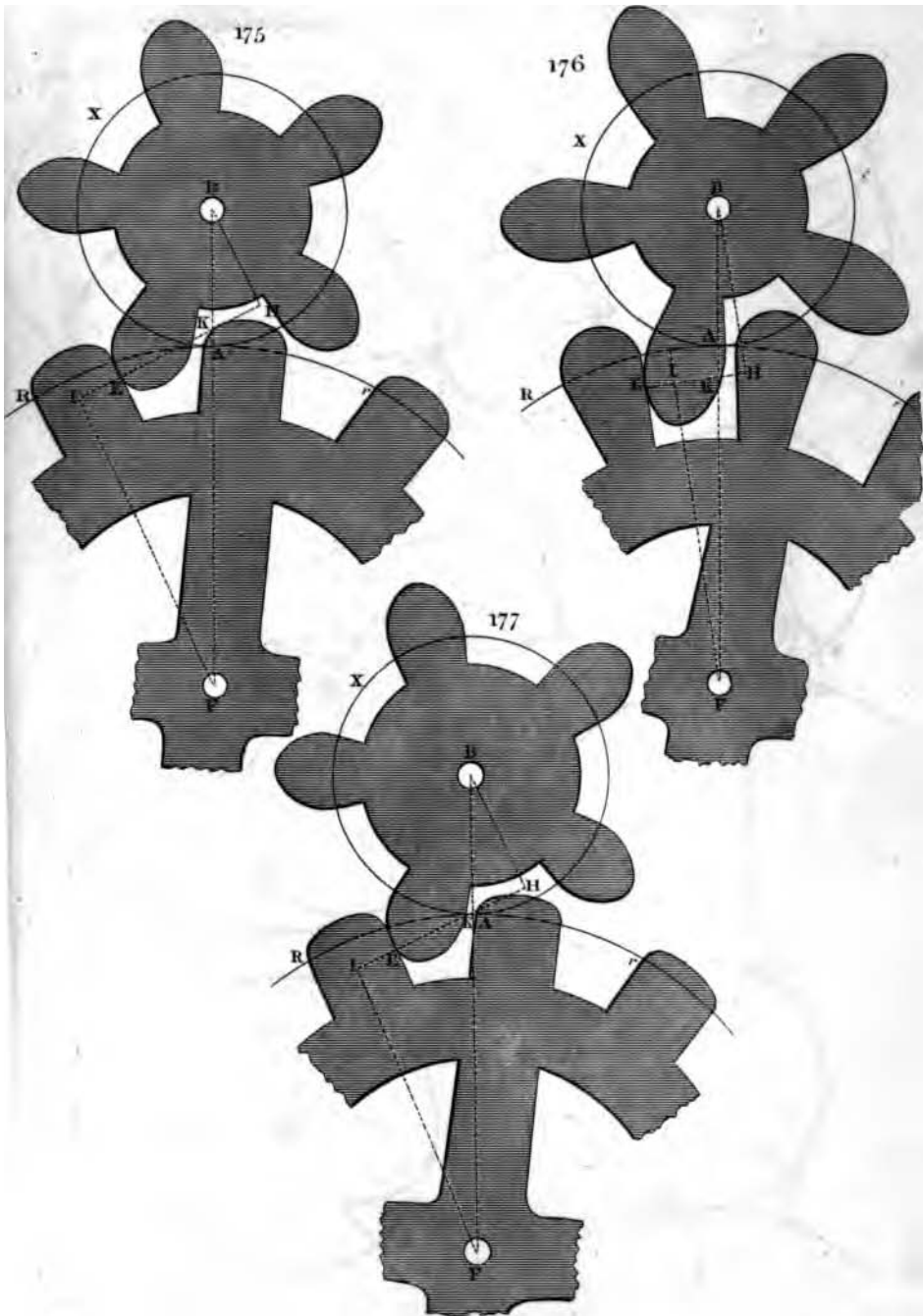

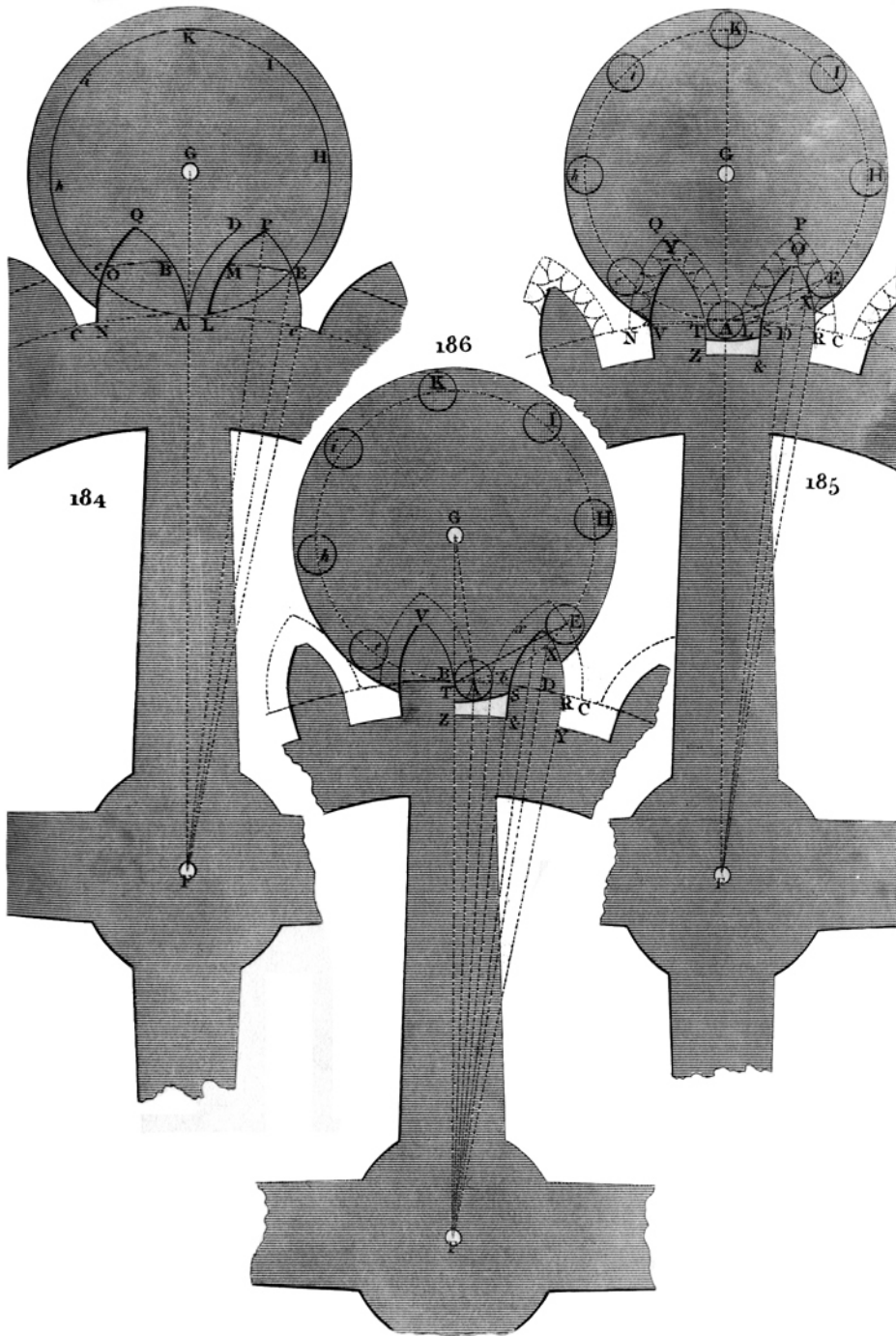

oth of Wheels.

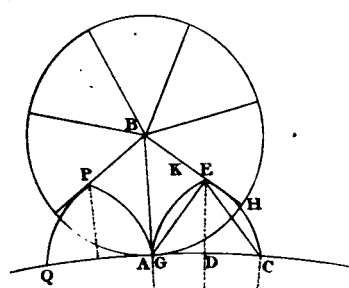

187

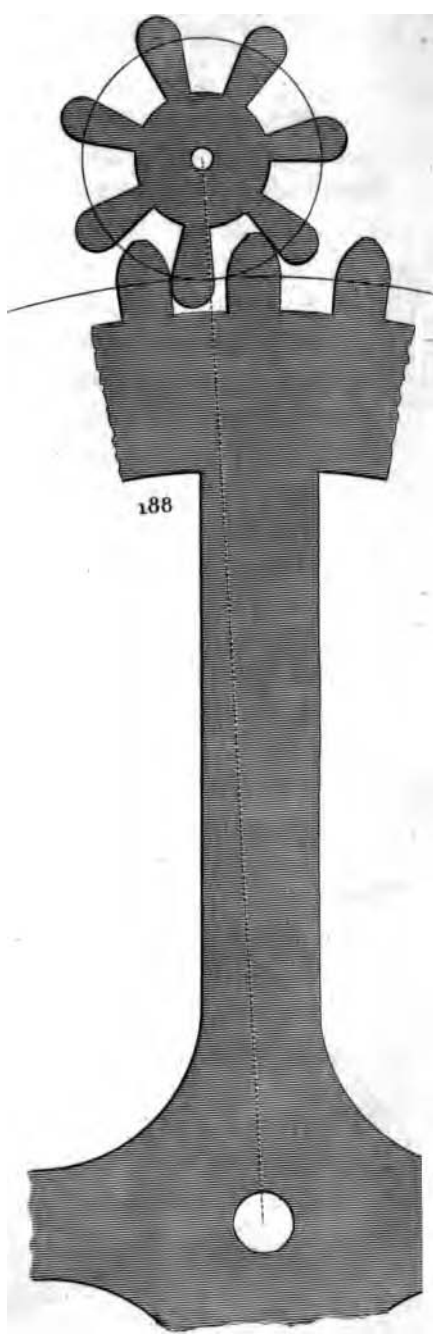

188

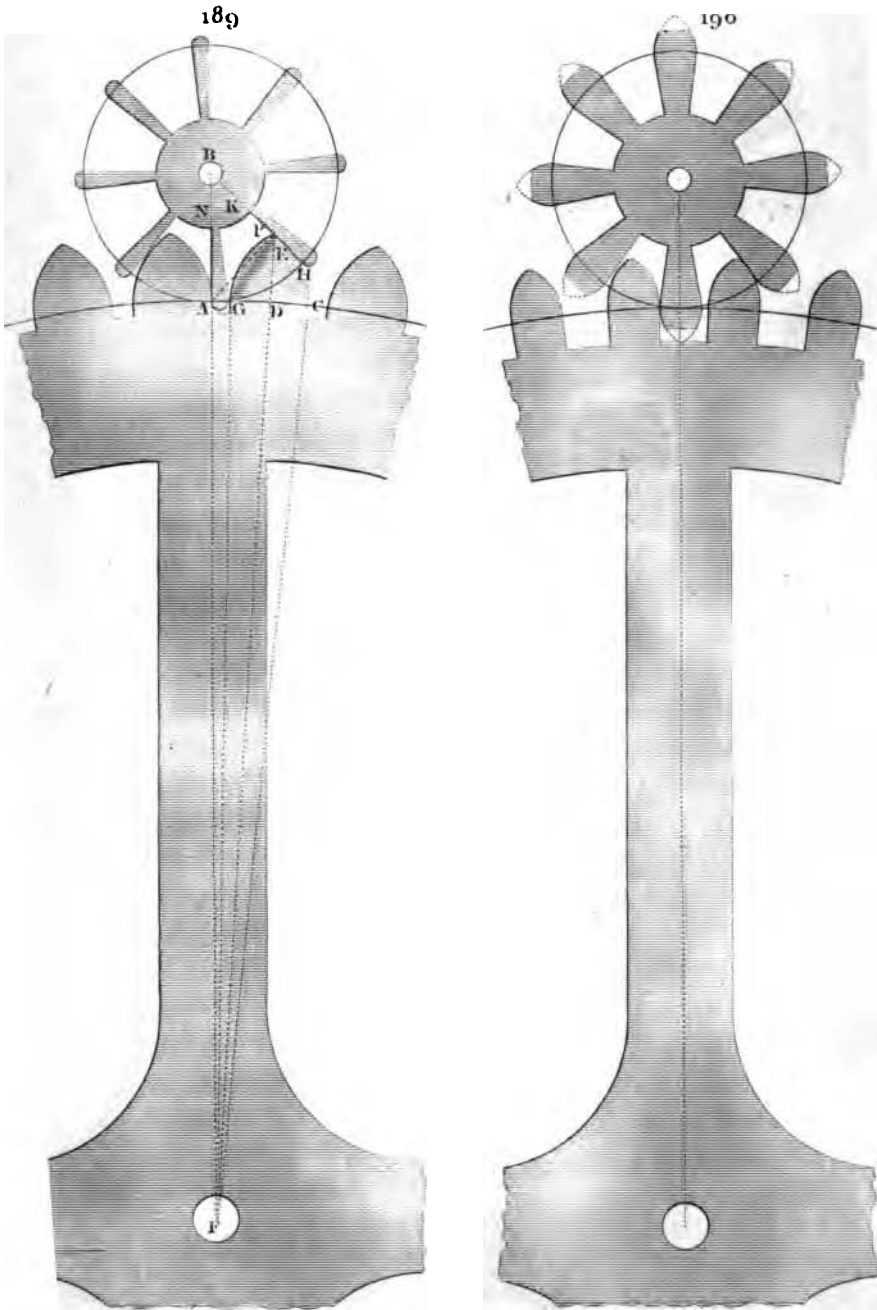

191

192

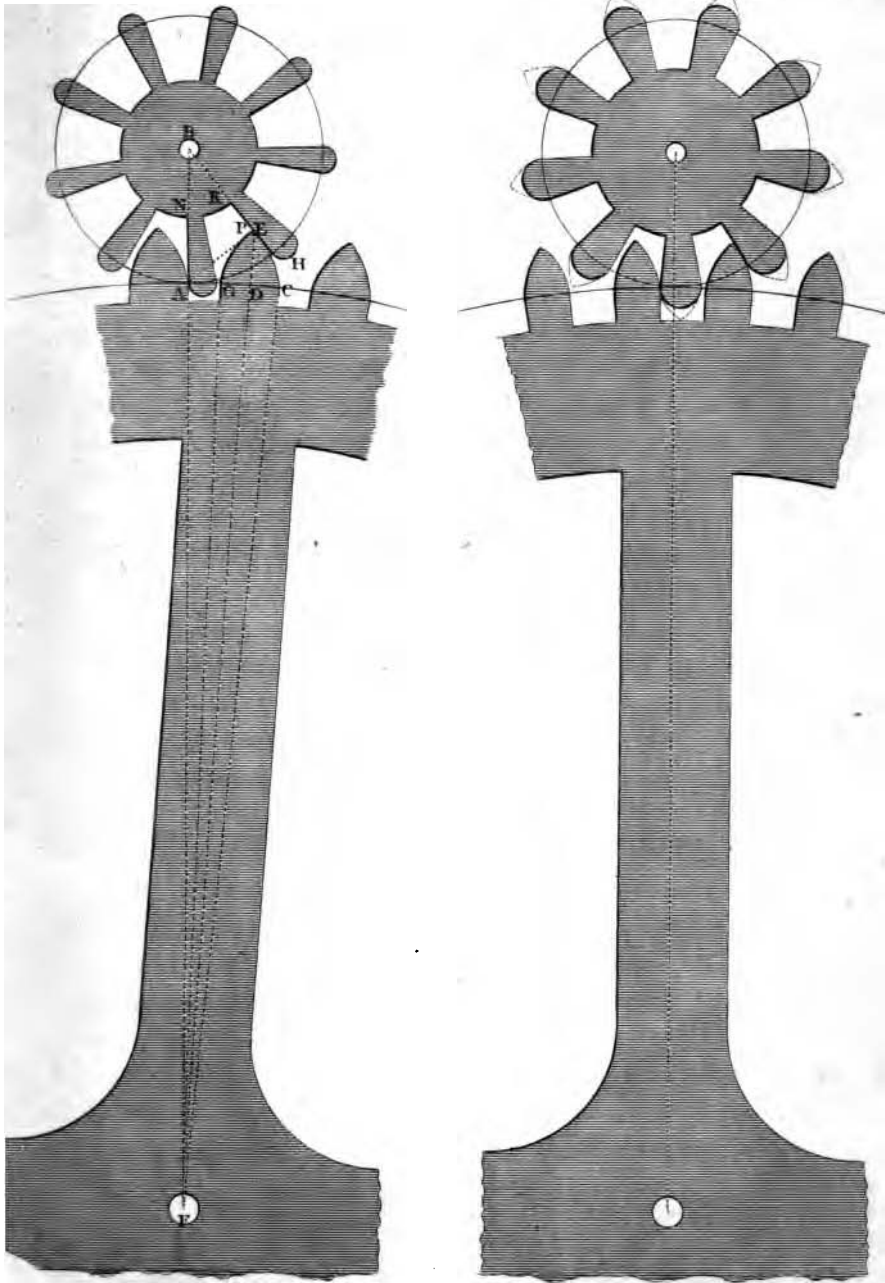

193

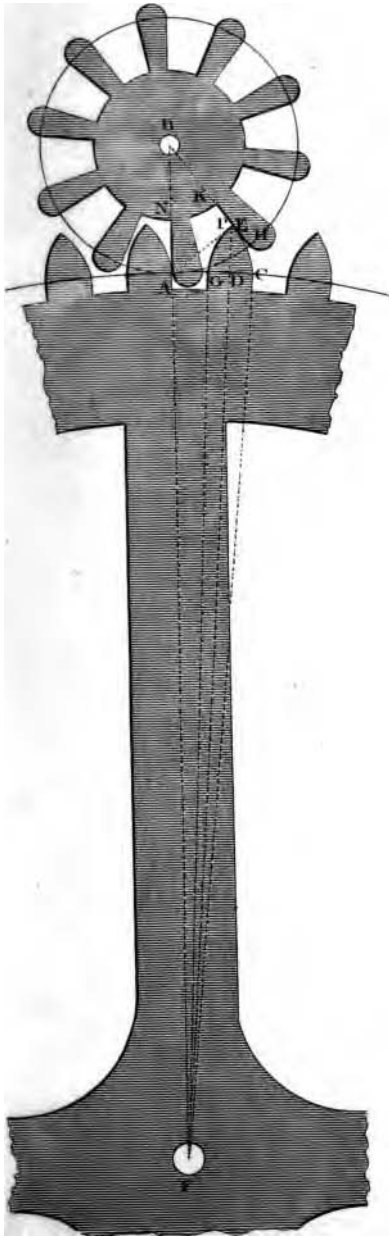

194



the Teeth of Wheels.

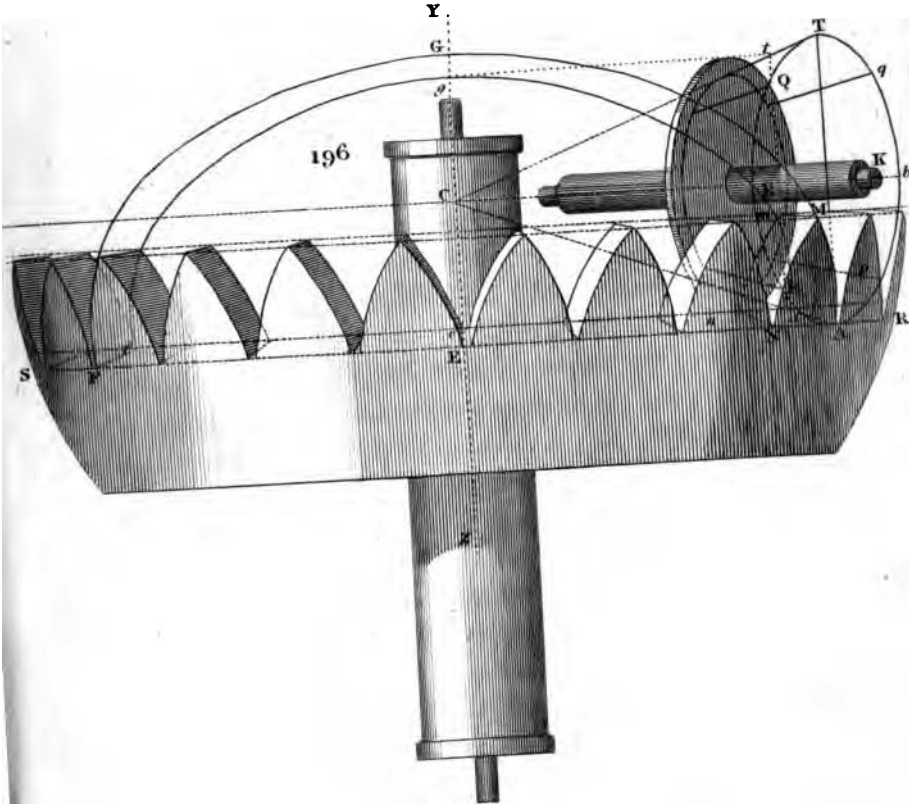
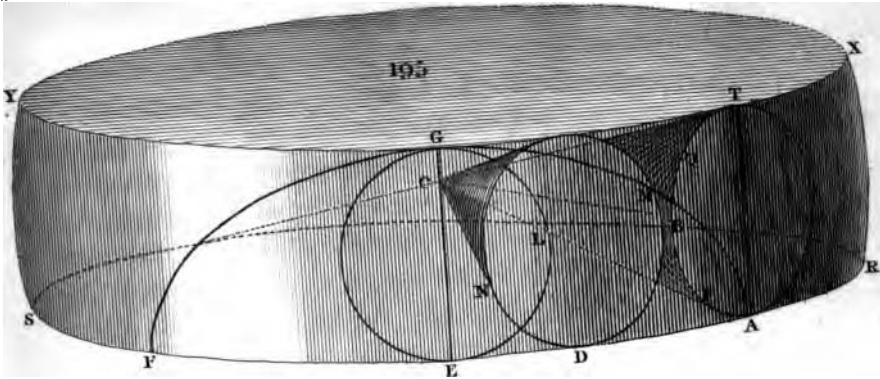

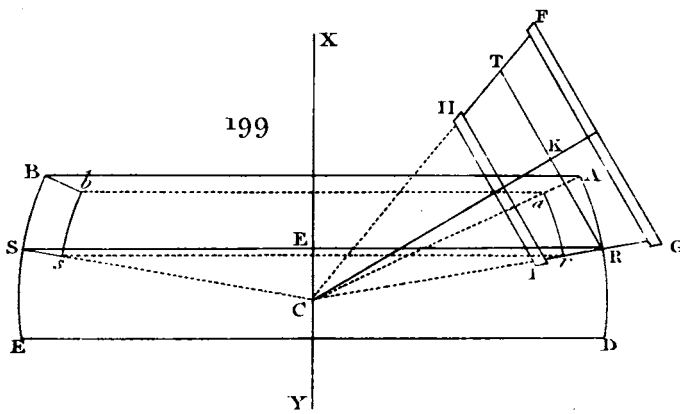
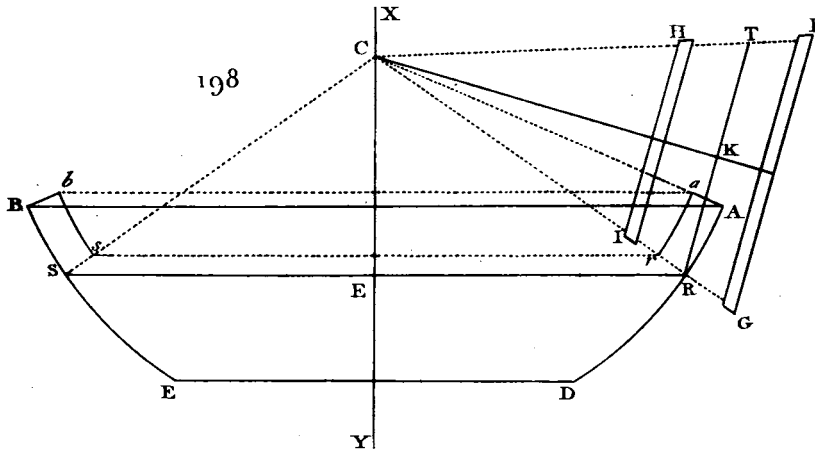
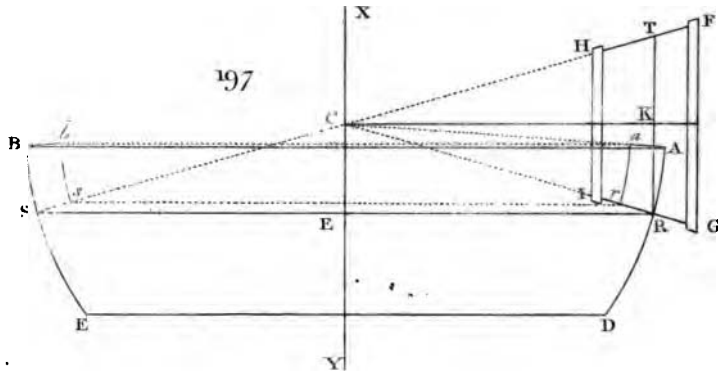

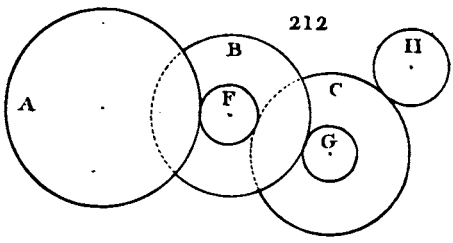
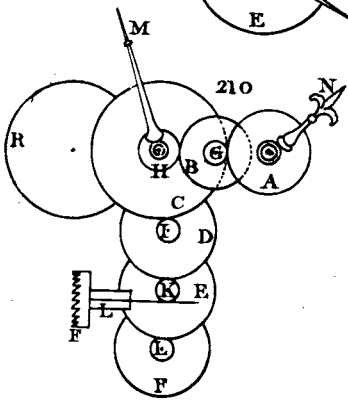
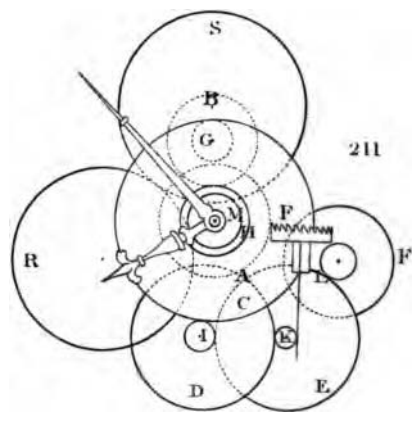
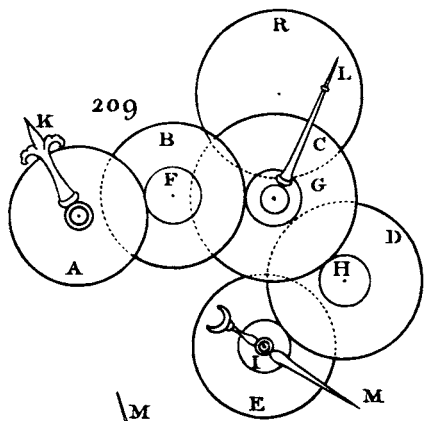
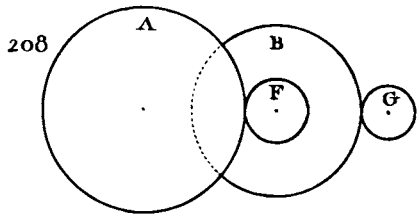
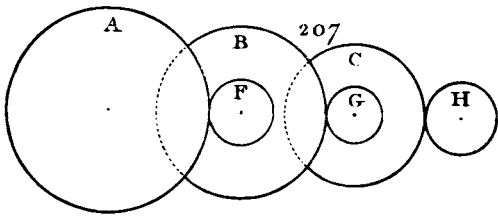
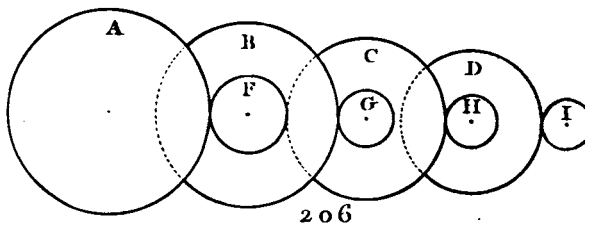
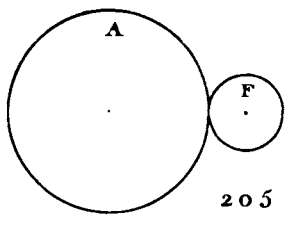

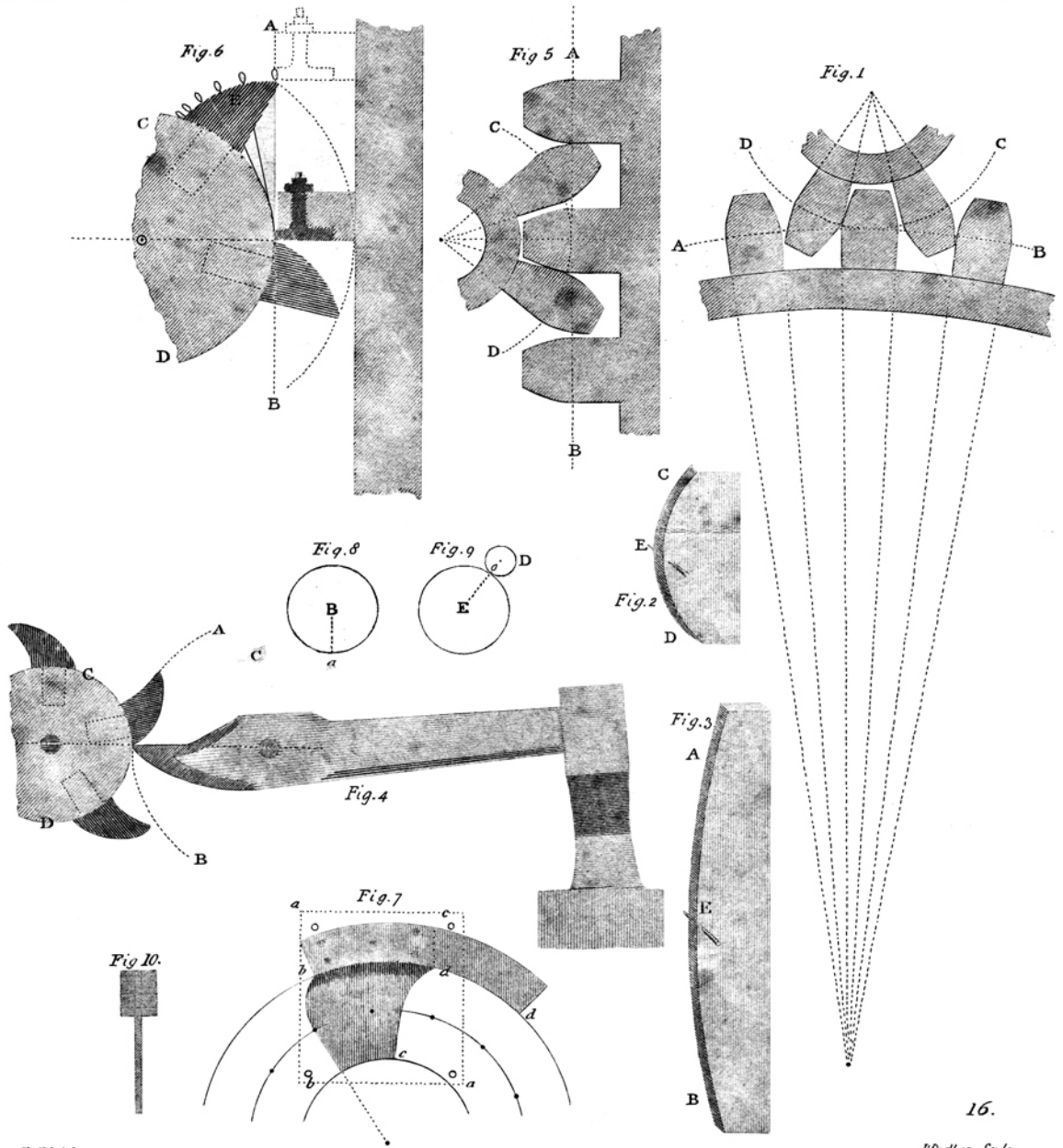

T. Gill. delin.

London. Published by J. Taylor, High Holborn.

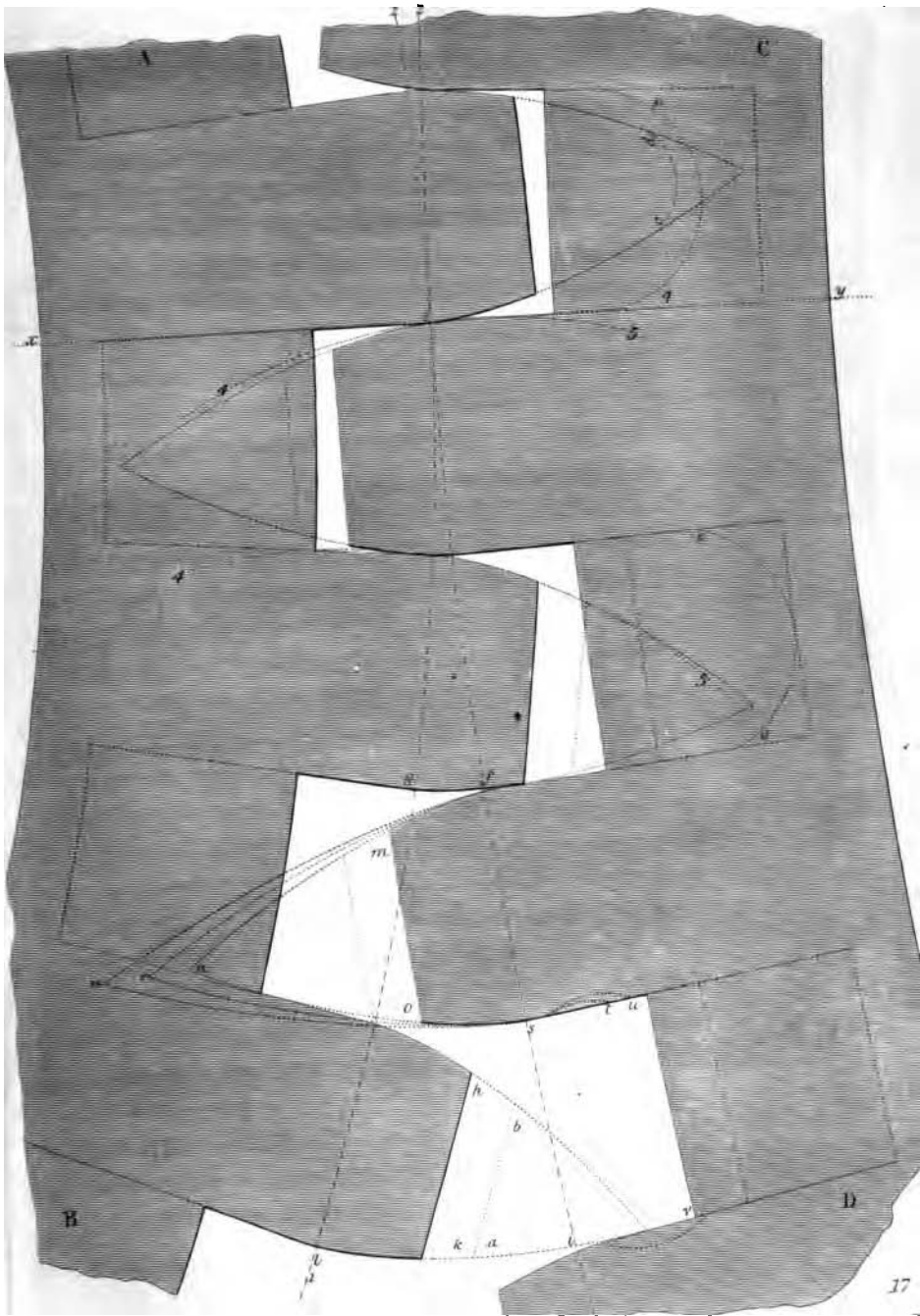

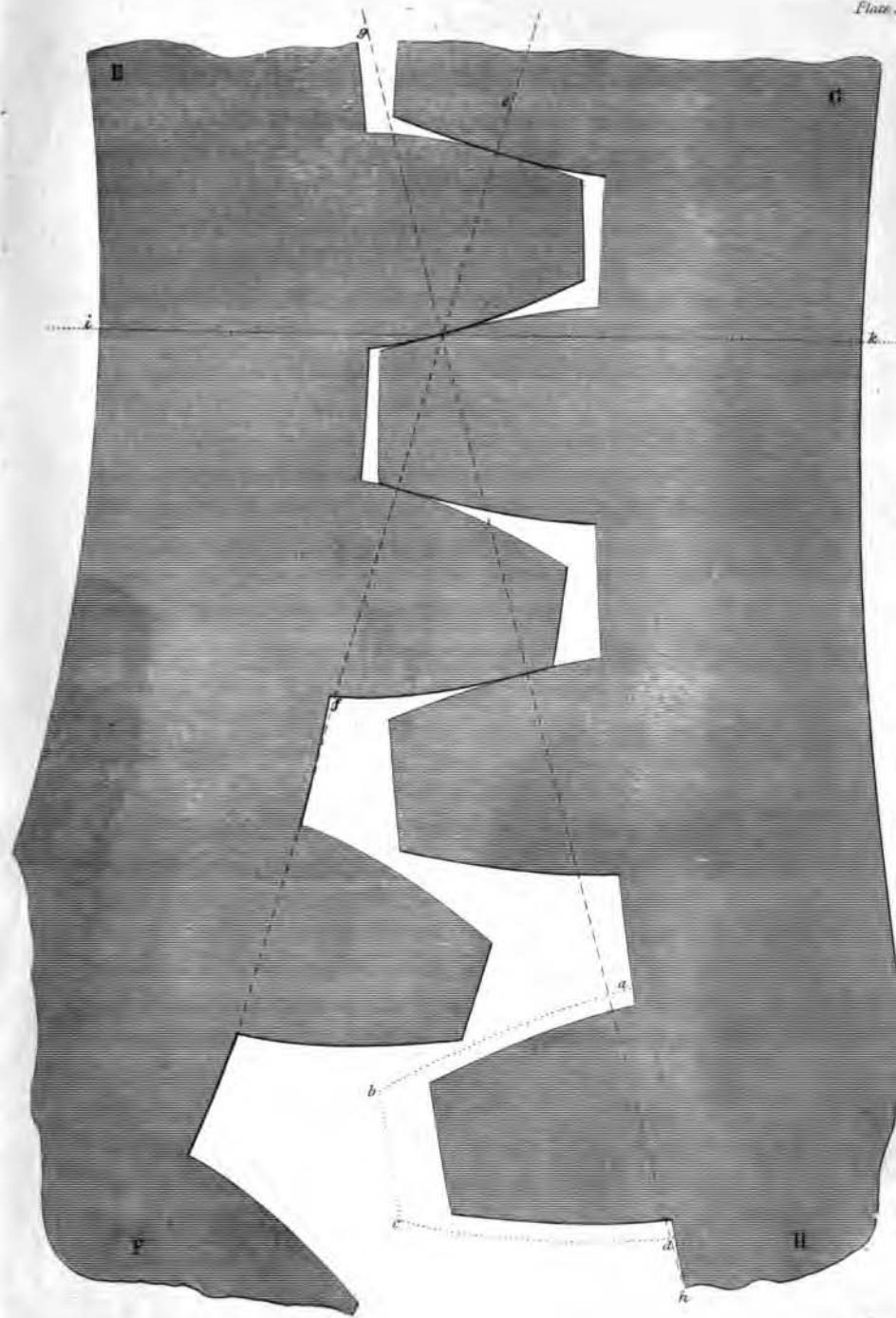

Fig 3

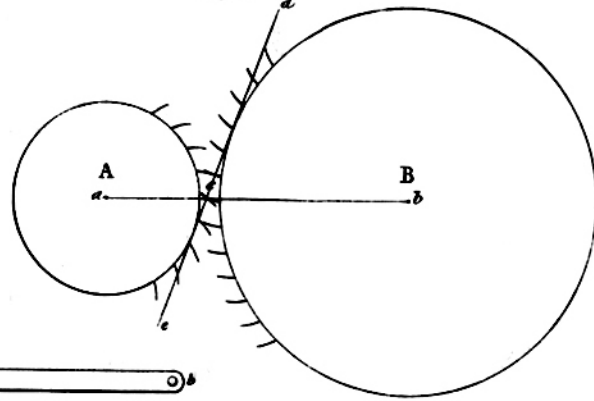

Fig 1

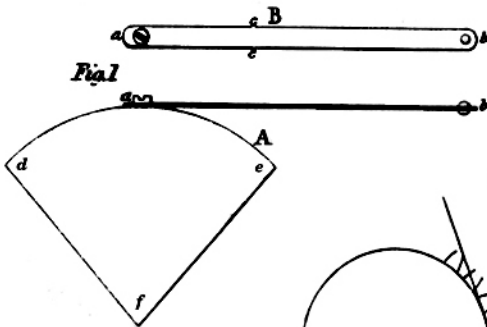

Fig 4

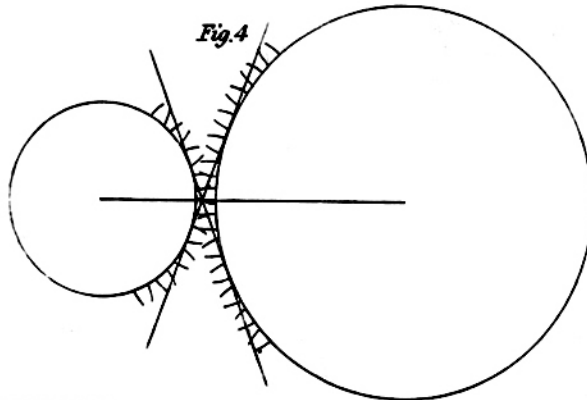

Fig 2

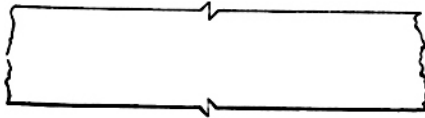

Fig 5

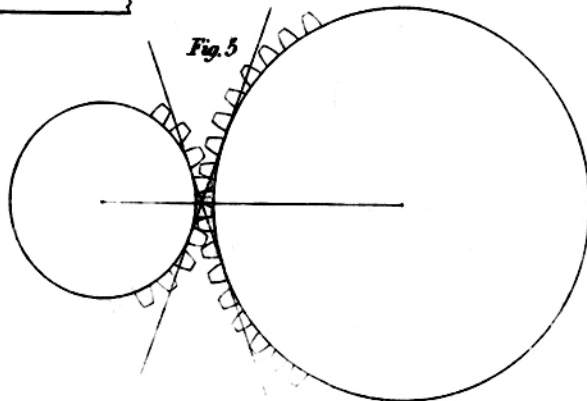

Fig 6

