

# TimeZone Watch School Illustrated Glossary of Watch Parts

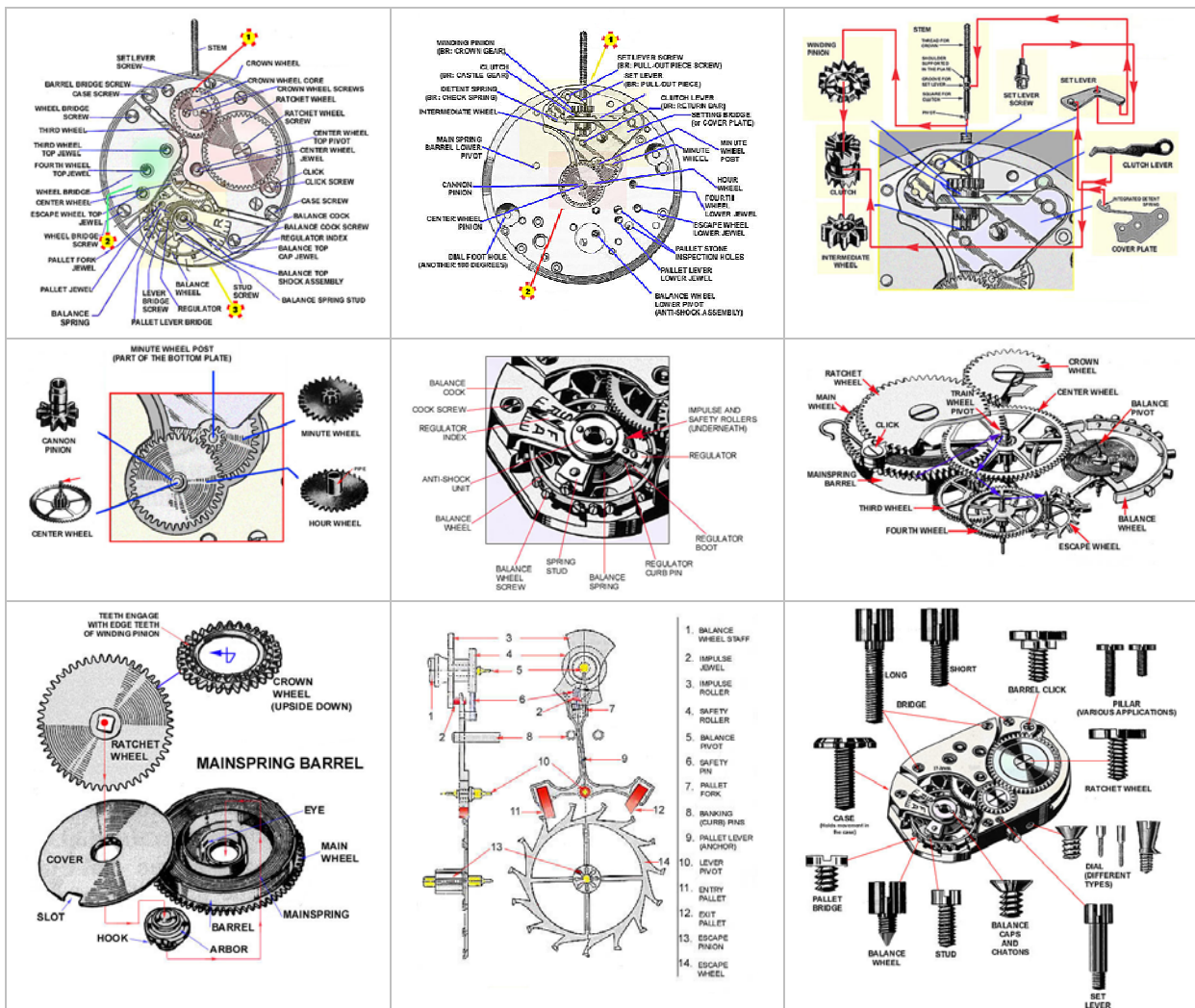

by Walt Odets

Copyright © A Bid Of Time, Inc., All Rights Reserved

Print version courtesy of Robert Biuk-Aghai

## **Notes on this print version**

This version was prepared using the material of the online Illustrated Glossary of Watch Parts hosted on the TimeZone Watch School website. The formatting and appearance of pages was made to follow the online version as closely as possible. Small deviations, however, were inevitable. This print version also contains numerous corrections of typos and other minor errors of the online version.

The online version of the Glossary is heavily cross-referenced with hyper-links from individual parts of text and images to other pages. Given the limitations of a paper version, these hyper-links could not be reproduced here in their original form. Instead, all links contained on a glossary page are listed in a separate table at the end of the page in this print version, with references to the corresponding pages they refer to.

The animation of the escapement, likewise, could not be reproduced here, and instead a sequence of 18 snapshots of the escapement is provided as an alternative.

Moreover, the overall structure of nine major sections and numerous detail pages was maintained, and can be identified in the capitalization of headings and cross-references: major sections are shown in all-capitals (such as in "THE BALANCE ASSEMBLY"), whereas detail pages are shown with initial capitals only (such as in "The Balance Staff").

It is hoped that this print version will be a convenient companion on the work table of the amateur watch maker.

Robert Biuk-Aghai  
Macau, December 2007

# Contents

<b>THE TOP PLATE .....</b>	<b>1</b>
<b>THE BOTTOM PLATE .....</b>	<b>3</b>
<b>THE KEYLESS WORKS.....</b>	<b>5</b>
Winding .....	6
Automatic Winding: The ETA Caliber 2842 .....	7
Automatic Winding: Bi-Directional Winding.....	8
Automatic Winding: The Jaeger LeCoultre Caliber 889/2 Switching Rocker .....	9
Patek Philippe caliber 240-PS .....	10
<b>THE MOTION WORKS .....</b>	<b>11</b>
The Cannon Pinion, Hour Wheel, Minute Wheel and Wheel Pinions ....	12
<b>THE BALANCE ASSEMBLY .....</b>	<b>14</b>
The Balance Wheel: Amplitude.....	16
The Balance Cock and Balance Assembly .....	17
The Balance Wheel in Detail.....	18
A Smooth Glucydur Balance.....	19
The Adjustable Mass Balance.....	20
The Regulator, Curb Pin and Boot.....	22
The Regulator, Spring Stud, and Anti-Shock Mechanism.....	23
The Anti-Shock Mechanism .....	24
The Balance Spring Collet and Overcoil.....	25
The Balance Staff .....	26
<b>THE ESCAPEMENT .....</b>	<b>27</b>
The Escapement: The Banking Pins .....	29
The Escapement: The Entry Pallet .....	30
The Escapement: The Exit Pallet.....	32
The Escapement: The Exit Pallet During Impulse.....	33
The Escapement: The Exit Pallet During Locking .....	34
The Escapement: The Pallet Lever Geometry .....	35
The Escapement: The Pallet Lever .....	36
The Escapement: The Pallet Lever Safety Pin .....	38
The Escapement: An Illustrated Explanation of Function .....	39

<b>THE MAINSPRING AND BARREL .....</b>	<b>42</b>
<b>The Click .....</b>	<b>44</b>
<b>The Click and Related Parts .....</b>	<b>46</b>
<b>The Mainspring of an Automatic Winding Watch .....</b>	<b>47</b>
<b>THE WHEEL TRAIN .....</b>	<b>48</b>
<b>The Center-Seconds Gear Train: The Fontainemelon Caliber 97 .....</b>	<b>49</b>
<b>The Conical Pivot and Jewel .....</b>	<b>51</b>
<b>The Cylindrical Pivot and Jewel.....</b>	<b>52</b>
<b>Wheels and Pinions .....</b>	<b>53</b>
<b>SCREWS.....</b>	<b>54</b>

# THE TOP PLATE

The movement as seen from the back of the watch:

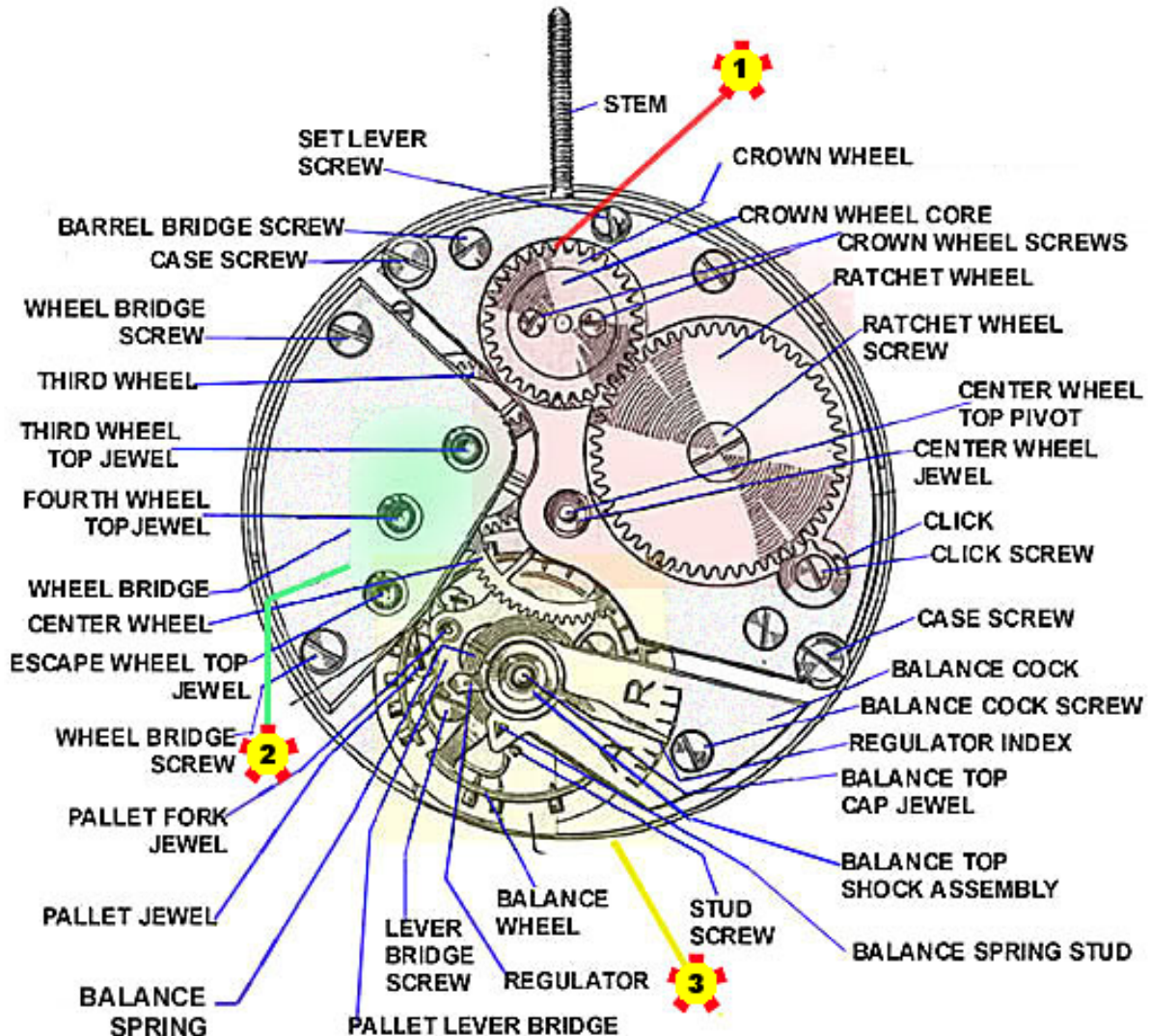

For info about...	See...
Stem	P. 5, THE KEYLESS WORKS
Crown Wheel	P. 48, THE WHEEL TRAIN
Crown Wheel Core	P. 48, THE WHEEL TRAIN
Crown Wheel Screws	P. 48, THE WHEEL TRAIN
Ratchet Wheel	P. 42, THE MAINSPRING AND BARREL
Ratchet Wheel Screw	P. 42, THE MAINSPRING AND BARREL
Center Wheel Top Pivot	P. 52, The Cylindrical Pivot and Jewel
Center Wheel Jewel	P. 52, The Cylindrical Pivot and Jewel
Click	P. 42, THE MAINSPRING AND BARREL
Click Screw	P. 42, THE MAINSPRING AND BARREL
Case Screw	P. 54, SCREWS
Balance Cock	P. 17, The Balance Cock and Balance Assembly
Balance Cock Screw	P. 14, THE BALANCE ASSEMBLY

Regulator Index	P. 17, The Balance Cock and Balance Assembly
Balance Top Cap Jewel	P. 24, The Anti-Shock Mechanism
Balance Top Shock Assembly	P. 24, The Anti-Shock Mechanism
Balance Spring Stud	P. 17, The Balance Cock and Balance Assembly
Stud Screw	P. 54, SCREWS
Balance Wheel	P. 18, The Balance Wheel in Detail
Regulator	P. 23, The Regulator, Spring Stud, and Anti-Shock Mechanism
Lever Bridge Screw	P. 54, SCREWS
Pallet Lever Bridge	P. 22, The Regulator, Curb Pin and Boot
Balance Spring	P. 18, The Balance Wheel in Detail
Pallet Jewel	P. 36, The Escapement: The Pallet Lever
Pallet Fork Jewel	P. 36, The Escapement: The Pallet Lever
Wheel Bridge Screw	P. 54, SCREWS
Escape Wheel Top Jewel	P. 53, Wheels and Pinions
Center Wheel	P. 53, Wheels and Pinions
Wheel Bridge	P. 48, THE WHEEL TRAIN
Fourth Wheel Top Jewel	P. 52, The Cylindrical Pivot and Jewel
Third Wheel Top Jewel	P. 52, The Cylindrical Pivot and Jewel
Third Wheel	P. 48, THE WHEEL TRAIN
Wheel Bridge Screw	P. 54, SCREWS
Case Screw	P. 54, SCREWS
Barrel Bridge Screw	P. 54, SCREWS
Set Lever Screw	P. 5, THE KEYLESS WORKS
* 1	P. 42, THE MAINSPRING AND BARREL
* 2	P. 48, THE WHEEL TRAIN
* 3	P. 17, The Balance Cock and Balance Assembly

# THE BOTTOM PLATE

The dial side of the movement:

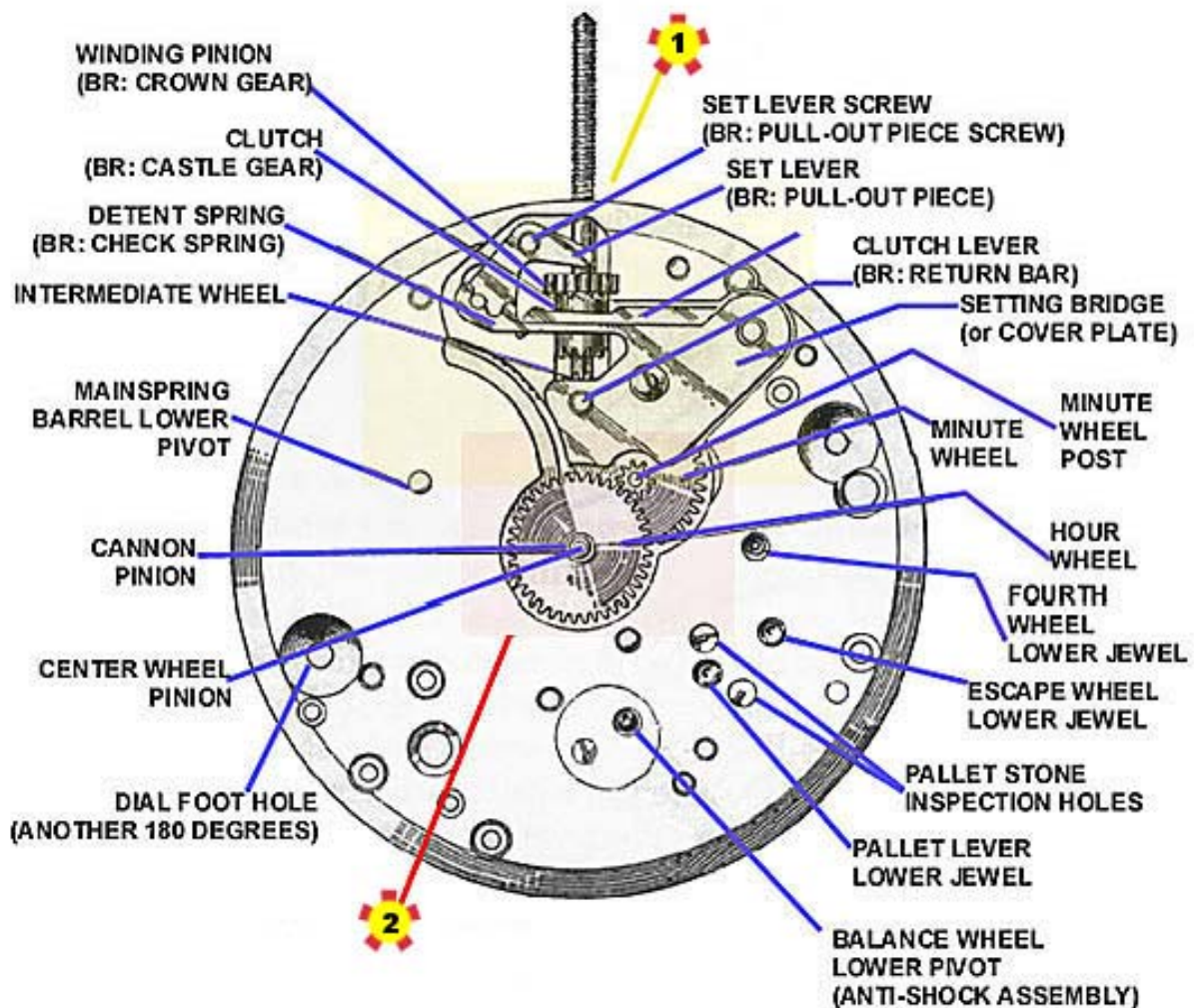

For info about...	See...
Set Lever Screw (BR: Pull-Out Piece Screw)	P. 5, THE KEYLESS WORKS
Set Lever (BR: Pull-Out Piece)	P. 5, THE KEYLESS WORKS
Clutch Lever (BR: Return Bar)	P. 5, THE KEYLESS WORKS
Setting Bridge (or Cover Plate)	P. 5, THE KEYLESS WORKS
Minute Wheel Post	P. 11, THE MOTION WORKS
Minute Wheel	P. 11, THE MOTION WORKS
Hour Wheel	P. 11, THE MOTION WORKS
Fourth Wheel Lower Jewel	P. 52, The Cylindrical Pivot and Jewel
Escape Wheel Lower Jewel	P. 51, The Conical Pivot and Jewel
Pallet Stone Inspection Holes	P. 36, The Escapement: The Pallet Lever
Pallet Lever Lower Jewel	P. 36, The Escapement: The Pallet Lever

Balance Wheel Lower Pivot (Anti-Shock Assembly)	P. 24, The Anti-Shock Mechanism
Dial Foot Hole	P. 54, SCREWS
Center Wheel Pinion	P. 53, Wheels and Pinions
Cannon Pinion	P. 11, THE MOTION WORKS
Mainspring Barrel Lower Pivot	P. 42, THE MAINSPRING AND BARREL
Intermediate Wheel	P. 5, THE KEYLESS WORKS
Detent Spring (BR: Check Spring)	P. 5, THE KEYLESS WORKS
Clutch (BR: Castle Gear)	P. 5, THE KEYLESS WORKS
Winding Pinion (BR: Crown Gear)	P. 5, THE KEYLESS WORKS
* 1	P. 5, THE KEYLESS WORKS
* 2	P. 11, THE MOTION WORKS



# THE KEYLESS WORKS

Winding and hand-setting:

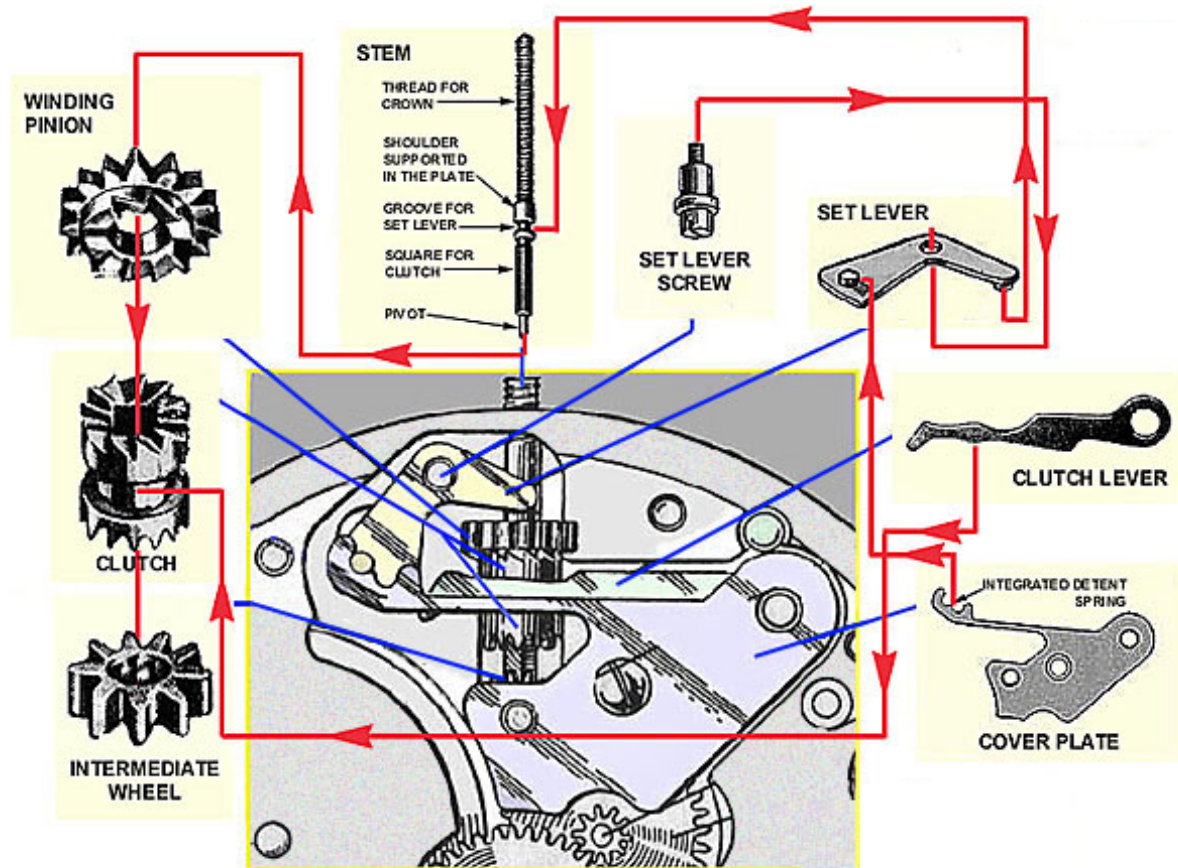

For info about...	See...
Set Lever Screw	P. 54, SCREWS
Winding	P. 6, Winding
The Bottom Plate	P. 3, THE BOTTOM PLATE

## Winding

For information on automatic winding watches see page 7.

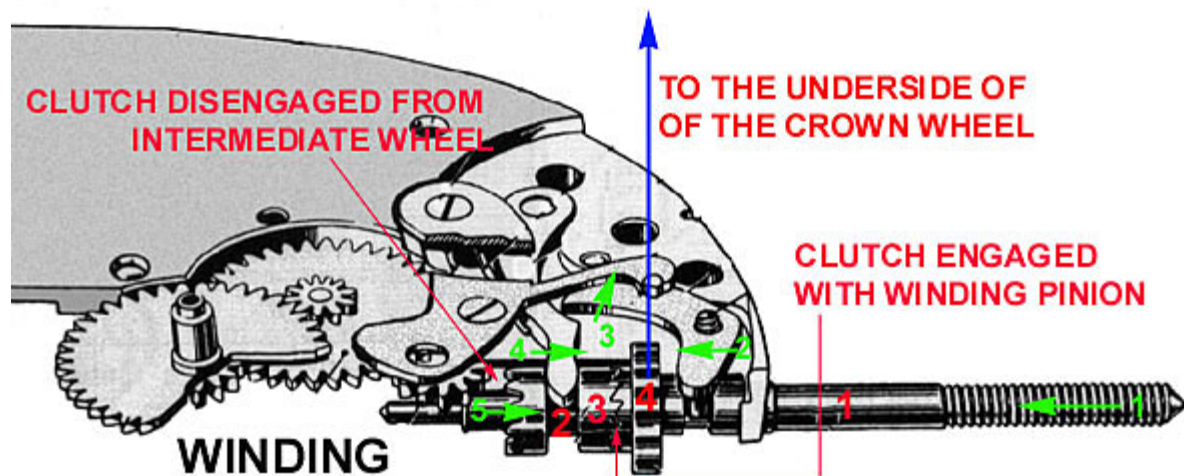

The positioning of the keyless-works parts for *winding* is shown in the green numbering. (1) The crown is pushed in, (2) the setting lever swings in, (3) the opposite end of the setting lever swings out allowing (4) the return lever to (5) slide the clutch into engagement with the winding pinion.

The red arrows show the power flow from (1) the stem, to (2) and (3) the clutch, to (4) the winding pinion, and then on to the crown gear and mainspring barrel (blue arrow).

During *hand setting*, all parts move in the direction *opposite* the green arrows. This brings the clutch into contact with the intermediate wheel, which drives the minute wheel, cannon pinion, and hour wheel.

The keyless works can be among the most beautiful parts of the mechanical watch. See page 8 for the keyless works of a contemporary Patek Philippe wristwatch caliber.

For info about...	See...
Crown Wheel	P. 48, THE WHEEL TRAIN
Crown Gear	P. 42, THE MAINSPRING AND BARREL
Mainspring Barrel	P. 42, THE MAINSPRING AND BARREL
Minute Wheel	P. 11, THE MOTION WORKS
Cannon Pinion	P. 11, THE MOTION WORKS
Hour Wheel	P. 11, THE MOTION WORKS

## Automatic Winding: The ETA Caliber 2842



The automatic winding watch converts motion of the wearer's wrist into power that winds the mainspring of the watch. As shown **left** (in an inverted position), most such watches use a central *rotor* with a gear (**yellow arrow**). As the rotor moves around its central pivot, the gear winds the watch.

In the second photograph, a typical contemporary automatic winding system is shown with the central rotor removed. This is an ETA caliber 2842. Identified parts include (1) the opening for the winding stem. (2) The

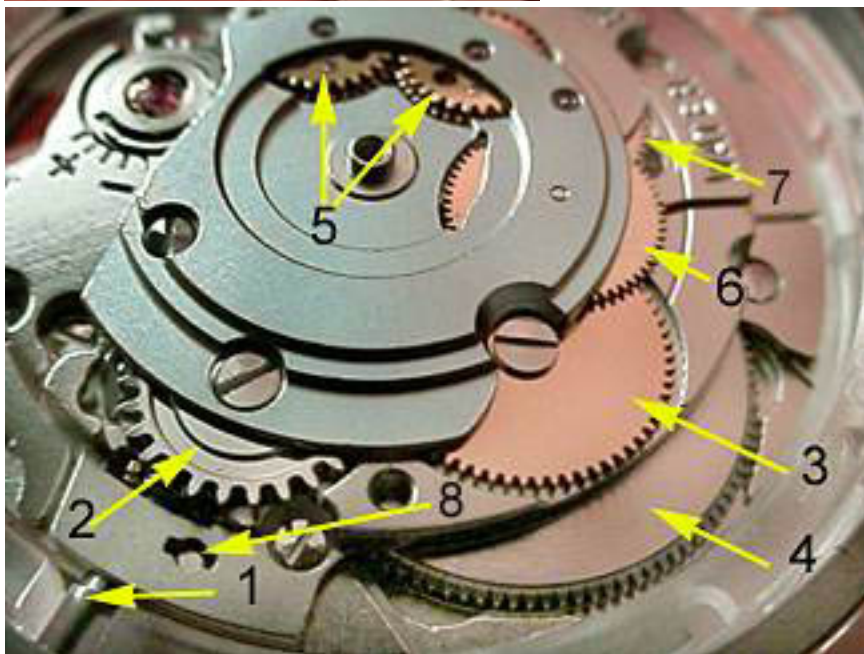

crown wheel (which transfers power from the winding stem to the ratchet wheel, arbor, and mainspring during hand winding). (3) The ratchet wheel (on top of the barrel and attached to the arbor and mainspring at the center of the barrel). (4) The mainspring barrel itself. (5) The twin click-wheels that receive power from the wheel on the central rotor (above).

(6) and (7) the reduction and transfer wheels that transmit power from the twin click-wheels to the ratchet wheel.

Because the ratchet wheel must always wind the mainspring in one direction (counterclockwise in the view above), the twin click-wheels convert rotation of the central rotor in *either direction* into power that will wind the mainspring.

See page 8 for a schematic of this winding train and understand how the twin click-wheels work.

## Automatic Winding: Bi-Directional Winding

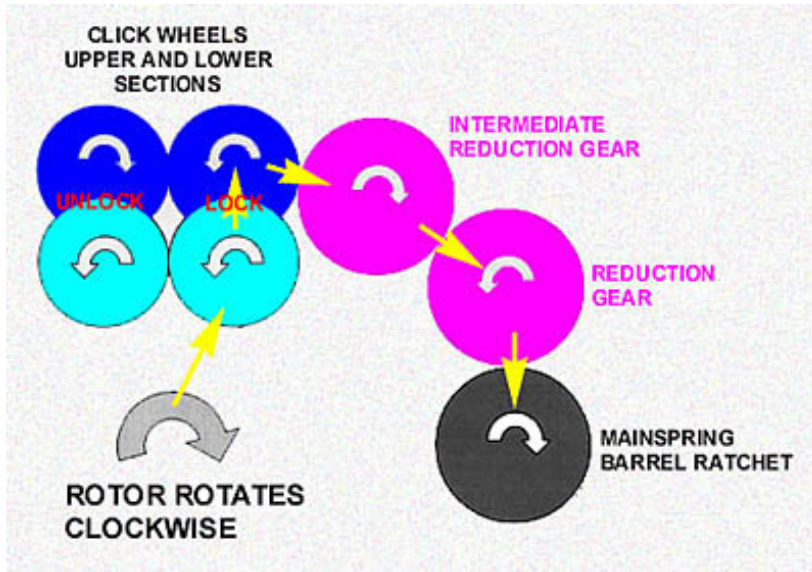

The twin click-wheels are each constructed of two parts, an **upper** and **lower** section (as shown in the diagram, **left**).

These upper and lower halves are locked or unlocked (with one-way ratchets), depending on the direction of rotation of the upper section. While both upper sections always rotate, the lower section rotates only on the locked wheel. With the central rotor moving clockwise, only the right click-wheel is locked. With the central rotor moving counterclockwise, only the left click-wheel is locked. This is the difference that allows the mechanism to utilize rotor rotation in both directions.

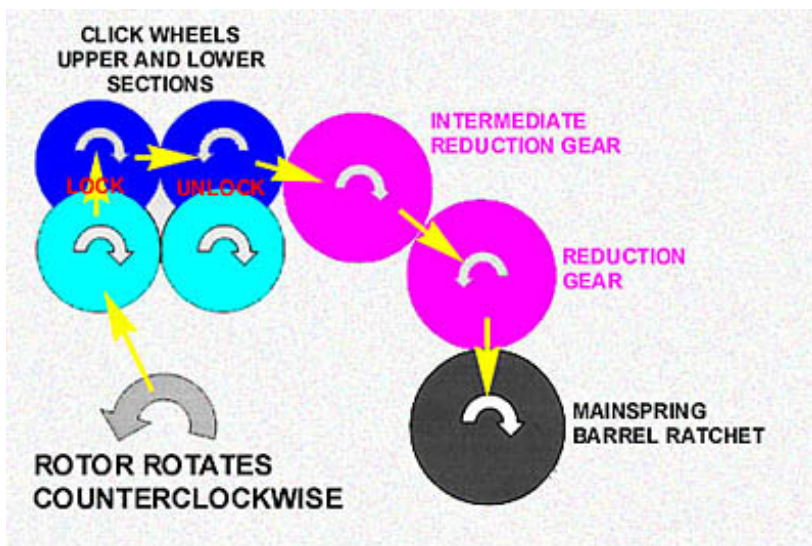

The upper illustration shows power flow (**yellow arrows**) with clockwise rotor rotation,

the lower with counterclockwise rotation.

See page 9 for another design of a bi-directional winding system, in the Jaeger LeCoultre caliber 889/2.

## Automatic Winding: The Jaeger LeCoultre Caliber 889/2 Switching Rocker

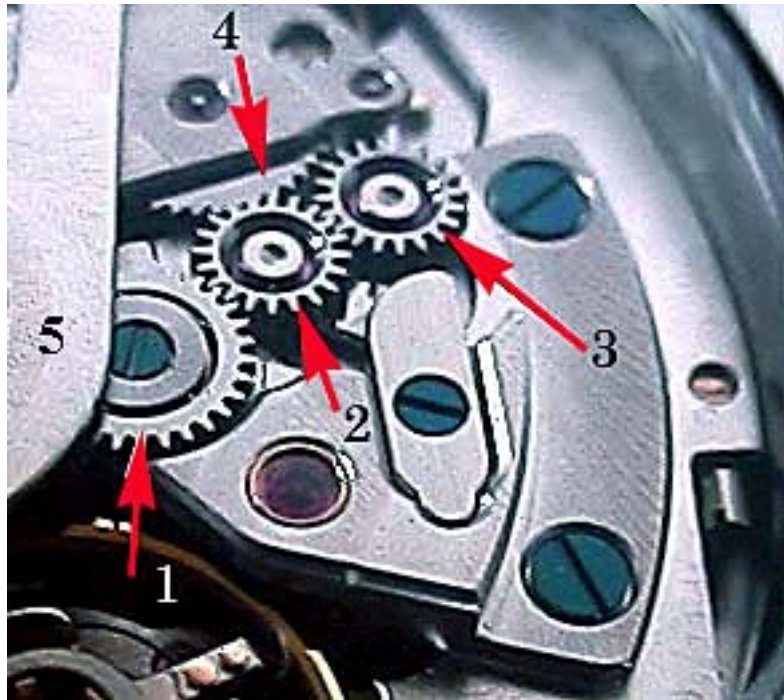

The illustrated Jaeger LeCoultre caliber 889/2 uses a *switching rocker* to accomplish bi-directional winding. This is an efficient, simple and elegant engineering solution. Power is transferred from the central rotor (5) to the first transfer wheel (1). Wheels (2) and (3) are mounted on a "switch plate" that swings back and forth and brings *either* (2) or (3) into connection with transfer wheel (4). In clockwise rotation of the central rotor, power is transferred from (5) to (1) to (2) to (4) and then on to the mainspring. In counterclockwise rotation of the central rotor, power is transferred from (5) to (1) to (2) to (3) to (4) and then on to the mainspring. So, the addition or removal of wheel (3) from the gear train allows wheel (4) to always rotate counterclockwise regardless of the direction of the central rotor. The direction of rotation of wheel (1) determines which way the rocker will switch.

## Patek Philippe caliber 240-PS



The illustration reveals the beautifully crafted keyless works of the contemporary Patek Philippe caliber 240-PS. It was Antoine Philippe who, in 1841, developed the concept of the keyless works that is still in use today. Before that time, winding and hand-setting were done with a separate key. (1) The cover (or bridge). (2) The setting lever (pull piece). (3) The clutch return lever. (The clutch, winding pinion, and stem are removed in this photograph.)

# THE MOTION WORKS

The Hour, Minute and Second Hands:

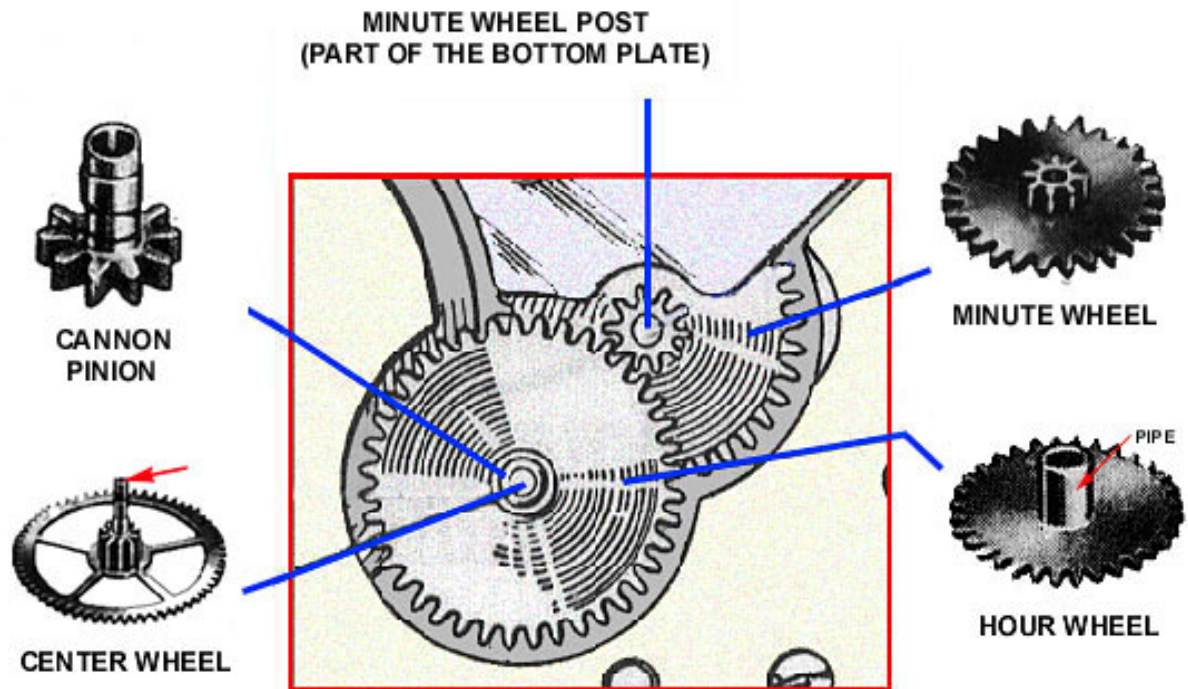

See P. 12 (The Cannon Pinion, Hour Wheel, Minute Wheel and Wheel Pinions) for a profile view.

For info about...	See...
Minute Wheel	P. 5, THE KEYLESS WORKS
Center Wheel	P. 48, THE WHEEL TRAIN
The Bottom Plate	P. 3, THE BOTTOM PLATE

# The Cannon Pinion, Hour Wheel, Minute Wheel and Wheel Pinions

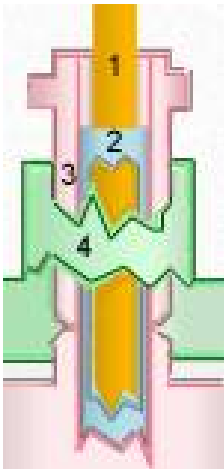

The illustration above shows the motion works of a center-seconds watch. (1) The fourth wheel pinion, which carries the seconds hand. (2) The center wheel pinion, which carries the cannon pinion. (3) The cannon pinion, which carries the minutes hand. (4) The hour wheel, which carries the hour hand.

For info about...	See...
Fourth Wheel Pinion (1)	P. 48, THE WHEEL TRAIN
Center Wheel Pinion (2)	P. 48, THE WHEEL TRAIN
Cannon Pinion (3)	P. 11, THE MOTION WORKS
Hour Wheel (4)	P. 11, THE MOTION WORKS

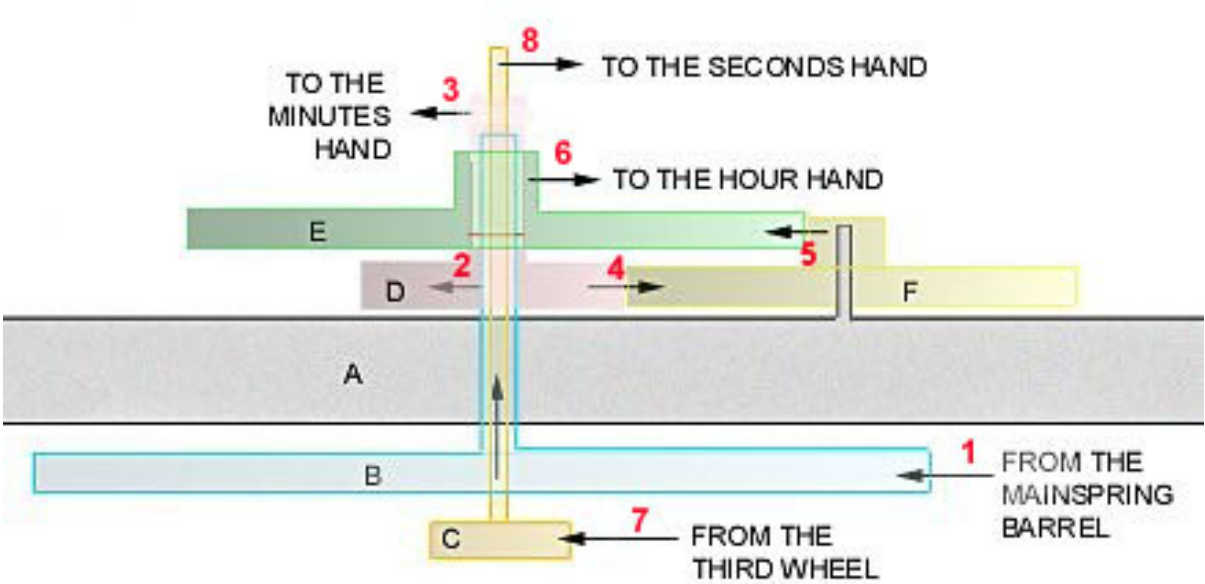

The second illustration diagrams the power flow from movement to hands. (A) The movement plate. (B) The center wheel. (C) The fourth wheel. (D) The cannon pinion.



(E) The hour wheel. (F) The minute wheel. You can follow the power flow with the red numbers, 1 through 8.

<b>For info about...</b>	<b>See...</b>
Movement Plate (A)	P. 3, THE BOTTOM PLATE
Center Wheel (B)	P. 48, THE WHEEL TRAIN
Fourth Wheel (C)	P. 48, THE WHEEL TRAIN
Cannon Pinion (D)	P. 11, THE MOTION WORKS
Hour Wheel (E)	P. 11, THE MOTION WORKS
Minute Wheel (F)	P. 11, THE MOTION WORKS
Fourth Wheel Pinion (8)	P. 53, Wheels and Pinions

## THE BALANCE ASSEMBLY

The Balance Wheel, Balance Spring and Balance Cock:

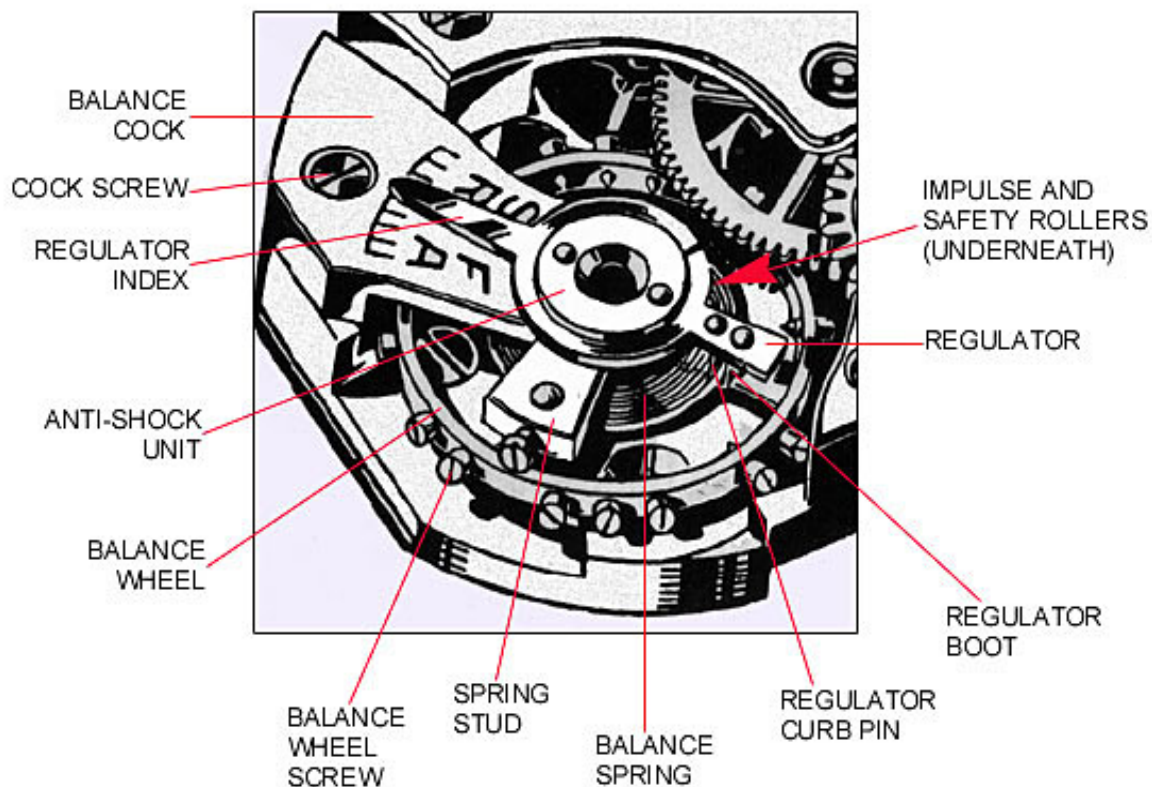

The back-and-forth oscillations of a balance wheel are described in terms of amplitude. See page 16 to understand amplitude.

For info about...	See...
Impulse and Safety Rollers	P. 18, The Balance Wheel in Detail
Regulator	P. 23, The Regulator, Spring Stud, and Anti-Shock Mechanism
Regulator Boot	P. 22, The Regulator, Curb Pin and Boot
Regulator Curb Pin	P. 22, The Regulator, Curb Pin and Boot
Balance Spring	P. 25, The Balance Spring Collet and Overcoil
Spring Stud	P. 17, The Balance Cock and Balance Assembly; P. 23, The Regulator, Spring Stud, and Anti-Shock Mechanism
Balance Wheel Screw	P. 54, SCREWS
Balance Wheel	P. 19, A Smooth Glucydur Balance; P. 20, The Adjustable Mass Balance
Anti-Shock Unit	P. 23, The Regulator, Spring Stud, and Anti-Shock Mechanism; P. 24, The Anti-Shock Mechanism
Regulator Index	P. 23, The Regulator, Spring Stud, and Anti-Shock Mechanism

Cock Screw	P. 54, SCREWS
Balance Cock	P. 17, The Balance Cock and Balance Assembly; P. 23, The Regulator, Spring Stud, and Anti-Shock Mechanism

## The Balance Wheel: Amplitude

Each clockwise or counterclockwise swing of the balance wheel is called a *beat*. The number of degrees of rotation of the beat is the *amplitude* of the balance. In most contemporary wristwatches, the amplitude of the balance in a horizontal position (i.e. dial up or dial down) should fall between 275 and 315 degrees. Low amplitude will affect the rate of the watch (speeding it up because the shorter swings complete more quickly). Excessive amplitude may result in the impulse pin on the impulse roller coming completely around and hitting the back of the pallet fork.

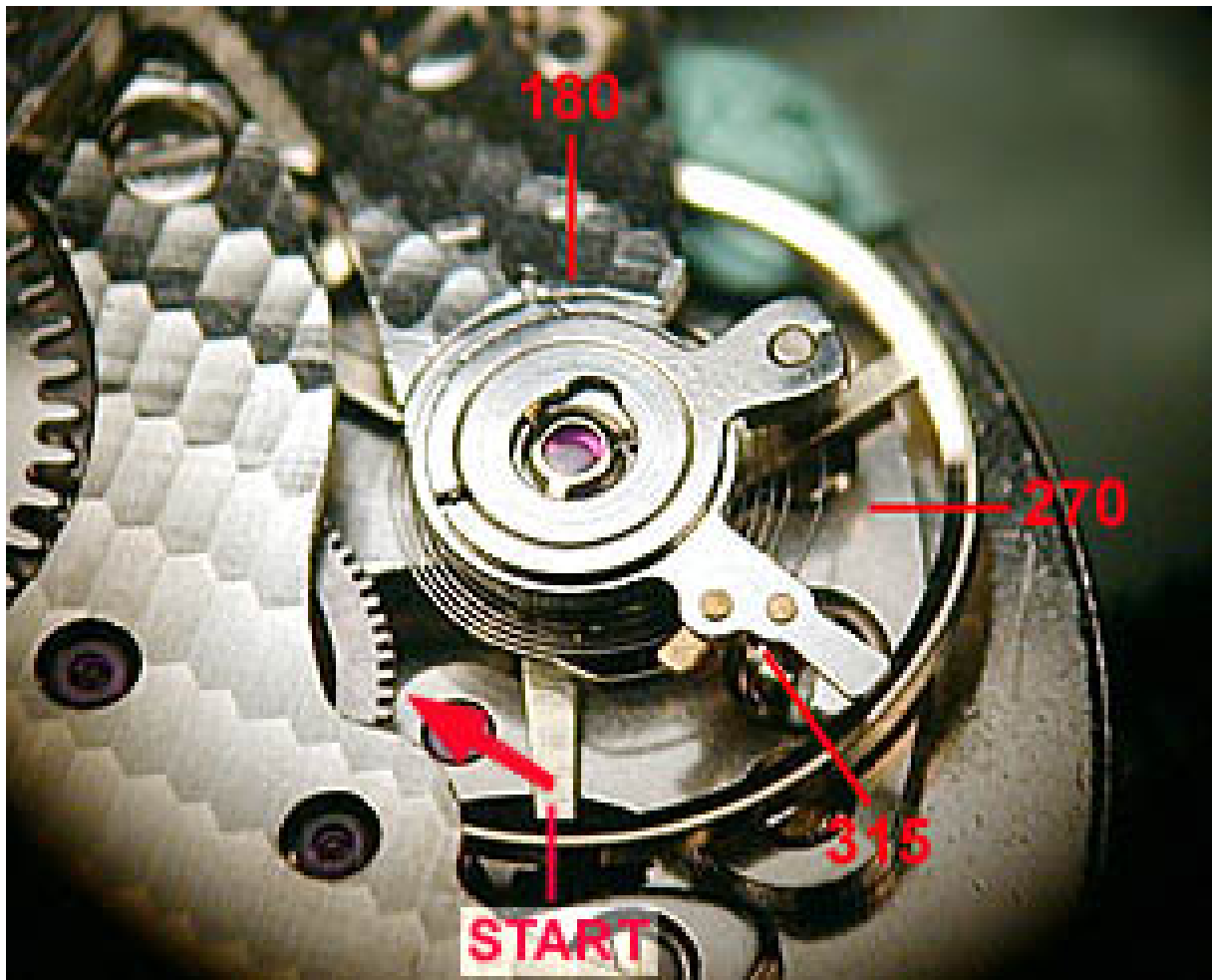

Amplitude may be measured with an electronic timer, or may be visually estimated. In the illustration the balance is in its centered (rest) position. The clockwise travel of one spoke (*bottom*) is indicated. Normally, the spoke will travel to between 275 and 315 degrees before reversing its direction, returning to center, and traveling 275 to 315 degrees counterclockwise.

For info about...	See...
Impulse Pin	P. 18, The Balance Wheel in Detail
Pallet Fork	P. 36, The Escapement: The Pallet Lever

## The Balance Cock and Balance Assembly

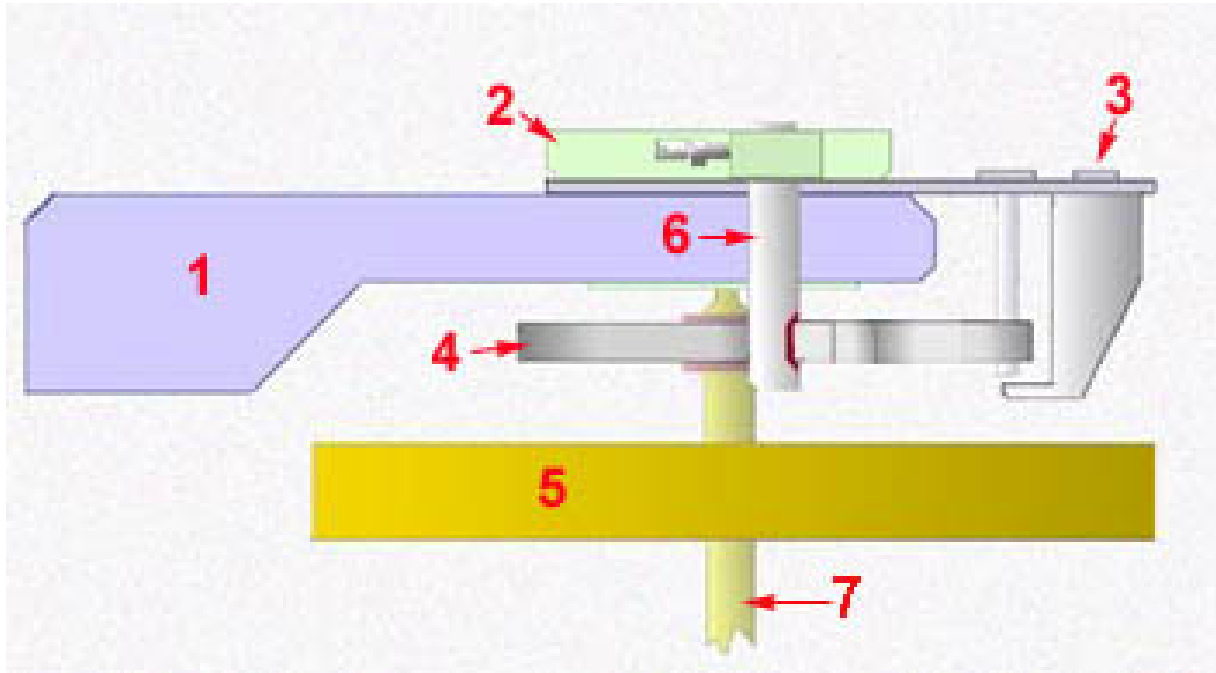

The entire balance cock and balance assembly is illustrated. (1) The balance cock. (2) The anti-shock unit for the upper balance pivot. (3) The regulator to control rate. (4) The balance spring. (5) The balance wheel. (6) The hairspring stud, which is held in the stud holder of the balance cock with the small set screw. (7) The balance staff.

For info about...	See...
Balance Cock (1)	P. 18, The Balance Wheel in Detail
Anti-Shock Unit (2)	P. 24, The Anti-Shock Mechanism
Regulator (3)	P. 22, The Regulator, Curb Pin and Boot
Balance Spring (4)	P. 18, The Balance Wheel in Detail
Balance Wheel (5)	P. 19, A Smooth Glucydur Balance
Hairspring Stud (6)	P. 23, The Regulator, Spring Stud, and Anti-Shock Mechanism
Balance Staff (7)	P. 26, The Balance Staff

## The Balance Wheel in Detail

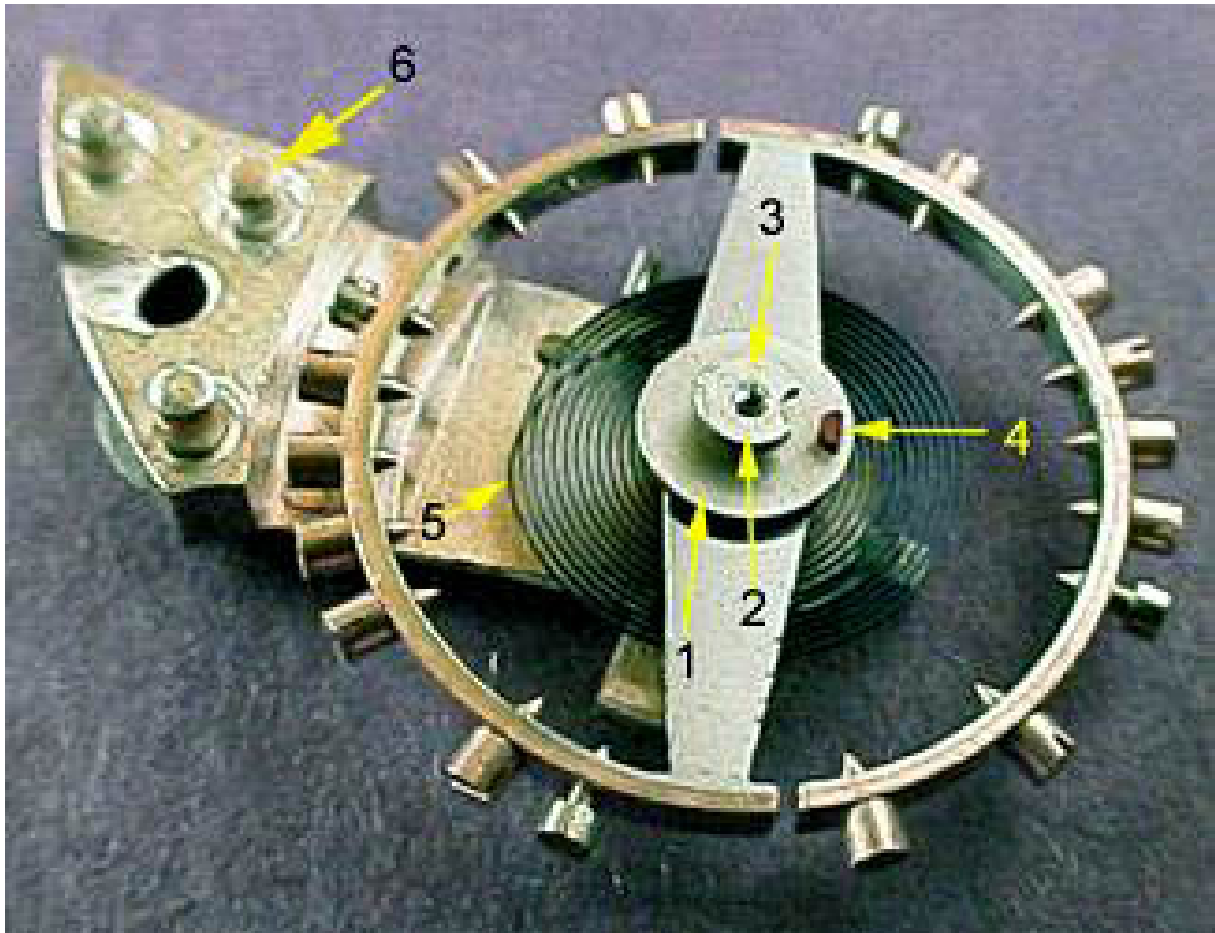

The balance illustrated is from a Longines pocket watch. The balance is of an older, split, bimetallic design, which is not often used in contemporary watches. (See page 19 for a more contemporary balance.) The screws around the rim of the balance wheel are used to adjust the poise ("balance") of the balance wheel, and, in split balances with steel balance springs, the temperature compensation. Such a split balance is made of layered steel and brass and is cut at two points near the balance arms. (1) The impulse roller. (2) The safety roller. (3) The lower balance pivot. (4) The impulse jewel (or impulse pin). (5) The balance spring (in this case an overcoil design). (6) The alignment pins used to locate the balance cock accurately on the main plate.

For info about...	See...
Impulse Roller (1)	P. 17, The Balance Cock and Balance Assembly
Safety Roller (2)	P. 17, The Balance Cock and Balance Assembly
Lower Balance Pivot (3)	P. 51, The Conical Pivot and Jewel
Impulse Jewel (4)	P. 17, The Balance Cock and Balance Assembly
Balance Spring (5)	P. 25, The Balance Spring Collet and Overcoil
Alignment Pins (6)	P. 23, The Regulator, Spring Stud, and Anti-Shock Mechanism
Balance Wheel Screws	P. 54, SCREWS

## A Smooth Glucydur Balance

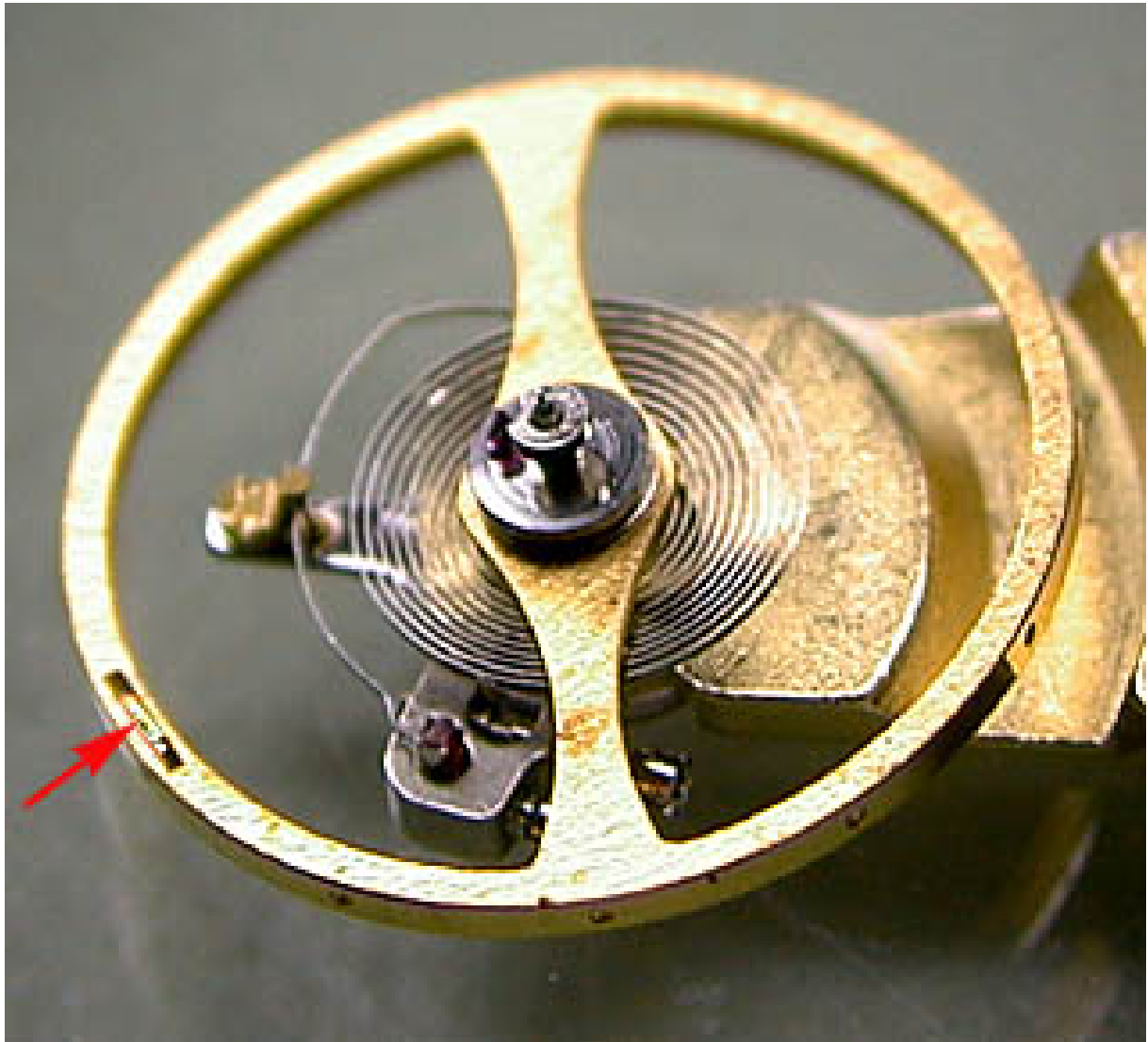

In most high-grade contemporary wristwatches, the balance wheel is like that illustrated above: a smooth (without rim screws) Glucydur two or three arm balance. The design is screwless because contemporary balance spring alloys provide temperature correction and make screws on the balance unnecessary for this purpose. The screwless design also has greater aerodynamic efficiency and is less likely to snag debris that might cause changes in timing. Glucydur is an alloy of (mostly) beryllium and copper and has excellent hardness and high stability over a range of temperatures. In most watches, the balance wheel is computer poised (and timed to the particular balance spring) and a precise laser cut is made in the underside of the rim (**red arrow**) to achieve nearly perfect poise.

See page 20 for a contemporary "adjustable-mass" Patek Philippe balance.

## The Adjustable Mass Balance

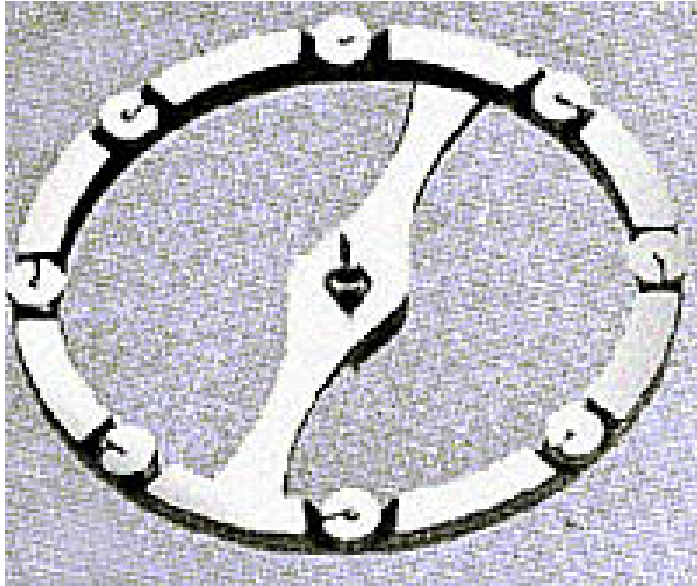

The *adjustable-mass* (or *adjustable-inertia*) balance wheel offers several advantages over conventional balance wheels with fixed mass. Used in most contemporary Patek Philippe wristwatches and pocket watches, the adjustable-mass balance has also long been used in marine chronometers.

Among the advantages of this design are elimination of the need for a conventional regulator (which can introduce several kinds of errors into positions timing), and precise adjustment of the balance for daily rate without disturbing other adjustments of the watch.

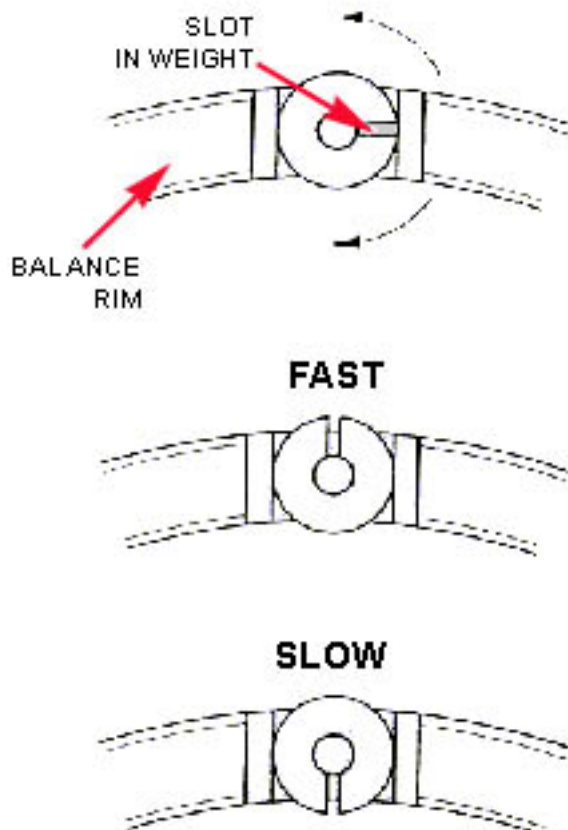

The illustrations show a Patek balance wheel, known by the trade name "Gyromax." The Gyromax is constructed of Glucydur. Eight small weights, slipped over posts are set down into the balance wheel rim as illustrated above. The weights may be rotated on their posts in opposing pairs to adjust the rate of the watch, or individually to adjust the poise ("balance") of the wheel. The weights are sometimes also used in positional adjustment of the watch.

As shown **left**, the circular weights contain a slot, which is the "light point" of the weight. If the weight is turned so that the slot is closer to the outside of the balance (away from the center), the mass of the balance is moved towards

the center. This speeds up the rate of the watch (opposing pairs of weights moved equally) or decreases the effective mass of the balance at that point (only one weight turned). Conversely, rotating a weight so that the slot is closer to the center decreases rate or increases the effective mass at that point of the rim.



See page 19 for a non-adjustable contemporary balance.

<b>For info about...</b>	<b>See...</b>
Regulator	P. 17, The Balance Cock and Balance Assembly
Glucydur	P. 19, A Smooth Glucydur Balance

## The Regulator, Curb Pin and Boot

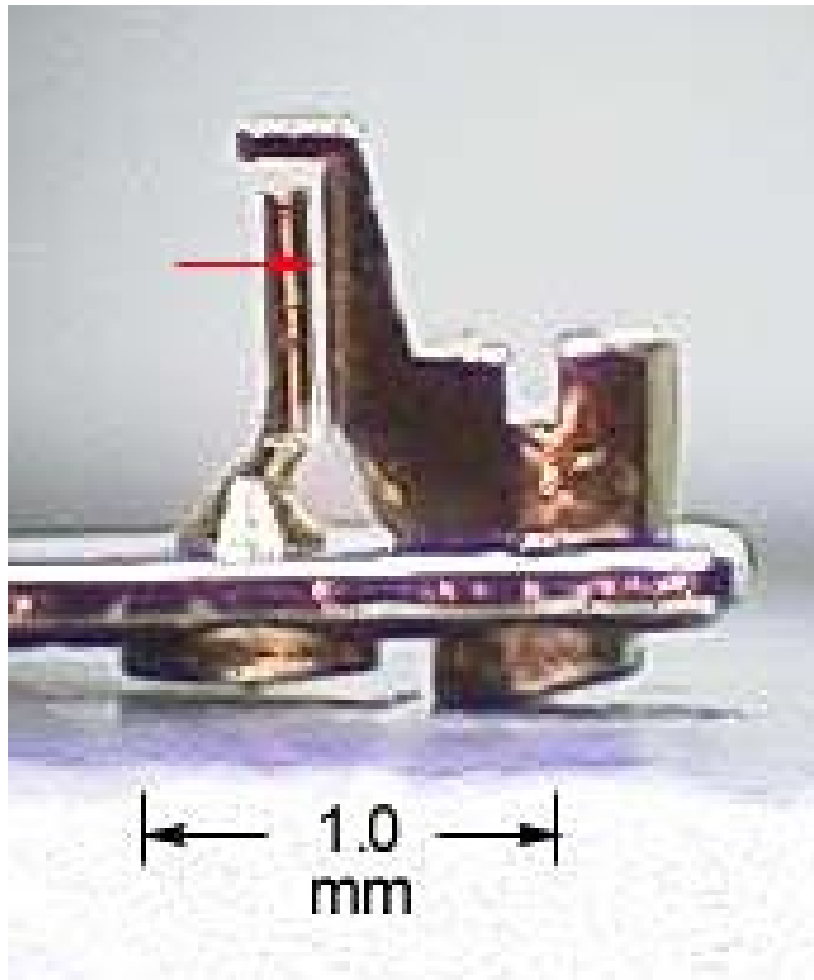

The regulator is shown inverted in this photograph, the curb pin on the left, the boot on the right. The balance spring passes through the space between the two (arrow), which determines the "effective" length (as opposed to actually total physical length) of the spring. This affects the rate of the watch. A shorter spring speeds up the watch, a longer one slows it down.

## The Regulator, Spring Stud, and Anti-Shock Mechanism



The balance cock assembly of a Nouvelle Lemania caliber 8815 is shown in this photograph. (1) The fine rate-adjustment screw. (2) The regulator with index (or curb) pin and boot. (3) The operative component of the fine adjustment regulator known as a "Triois" regulator. (4) The anti-shock unit for the upper balance pivot with a characteristic KIF-brand spring. (5) The stud for the outer attachment of the balance spring with the small screw that holds the end of the spring.

See page 17 for a schematic view of the regulator and balance cock.

For info about...	See...
Fine rate-adjustment screw (1)	P. 17, The Balance Cock and Balance Assembly
Regulator with Index (or Curb) Pin and Boot (2)	P. 22, The Regulator, Curb Pin and Boot
Triois Regulator (3)	P. 17, The Balance Cock and Balance Assembly
Anti-Shock Unit (4)	P. 24, The Anti-Shock Mechanism
Balance Spring Stud (5)	P. 17, The Balance Cock and Balance Assembly

## The Anti-Shock Mechanism

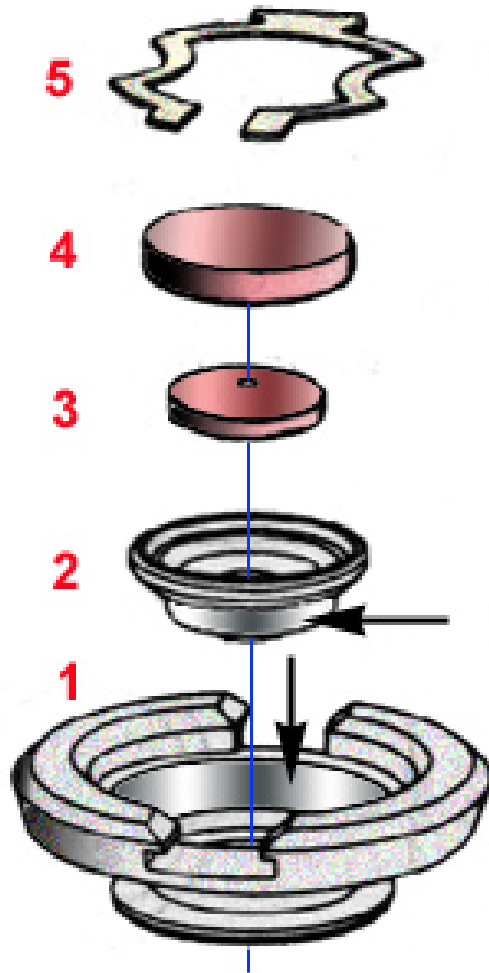

Anti-shock assemblies are used to protect the upper and lower balance pivots from damage due to external impact on the watch. In some movements, shock assemblies are also used on the escape wheel.

A typical anti-shock assembly consists of (1) the block, (2) the jewel housing, (3) the pierced jewel, (4) the cap jewel, and (5) the retaining spring.

The tip of the balance pivot extends through the block, jewel housing, pierced jewel, and rides on the under-surface of the cap jewel (as shown by the vertical blue line). The retaining spring holds the cap and pierced jewels and their jewel housing in place in the block.

The jewel housing and block have polished surfaces (arrows) that allow the jewel housing (and thus the balance pivot) to displace laterally during horizontal shock. During vertical shock, the retaining spring allows the cap jewel to rise and relieve stress on the pivot. The retaining spring returns the entire assembly to normal position after the shock.

The anti-shock assembly utilizes conical pivots on the balance staff (see P. 51, The Conical Pivot and Jewel).

See page 23 for a photograph of a KIF-brand anti-shock unit.

## The Balance Spring Collet and Overcoil

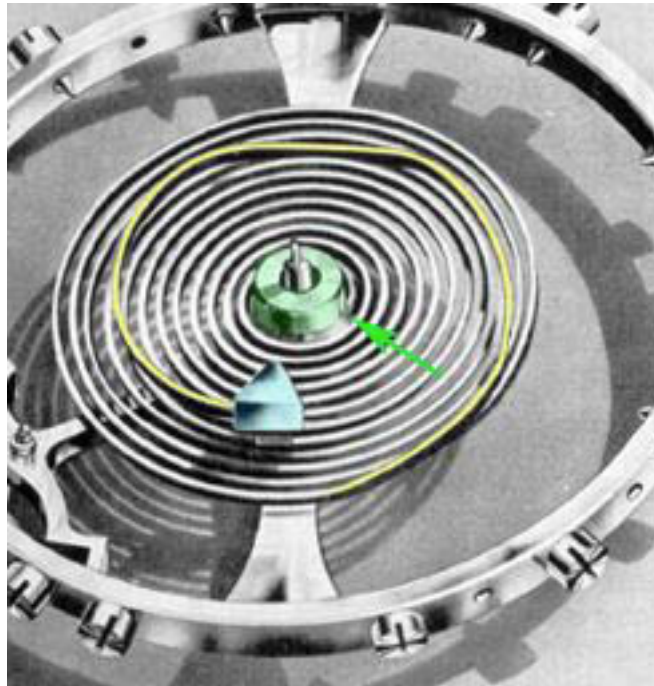

The *collet* (**green arrow**) sits on the balance shaft and attaches the inner end of the balance spring to the balance shaft. In this illustration, the balance spring is an *overcoil* design, the overcoil indicated in yellow. The **blue triangle** represents the spring stud on the balance cock.

Although the overcoil design (also known as a "Breguet spring") is not often used in contemporary wristwatches because of its susceptibility to shock, it prevents shifting of the center of gravity of the spring during balance rotation and improves positional adjustment of the watch.

<b>For info about...</b>	<b>See...</b>
Balance Spring Collet	P. 18, The Balance Wheel in Detail
Balance Shaft	P. 26, The Balance Staff
Balance Spring	P. 18, The Balance Wheel in Detail
Balance Wheel	P. 18, The Balance Wheel in Detail
Spring Stud	P. 17, The Balance Cock and Balance Assembly
Balance Rotation	P. 16, The Balance Wheel: Amplitude

## The Balance Staff

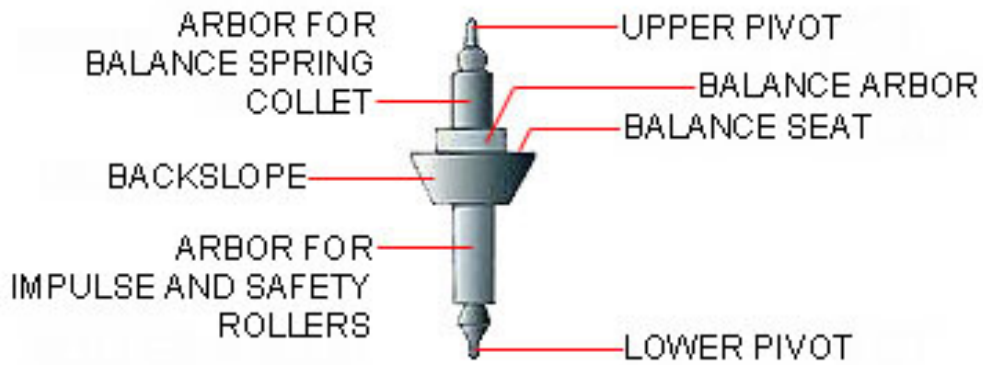

<b>For info about...</b>	<b>See...</b>
Arbor for Balance Spring Collet	P. 25, The Balance Spring Collet and Overcoil
Arbor for Impulse and Safety Rollers	P. 18, The Balance Wheel in Detail
Safety Rollers	P. 38, The Escapement: The Pallet Lever Safety Pin
Upper Pivot	P. 51, The Conical Pivot and Jewel
Balance Arbor	P. 18, The Balance Wheel in Detail
Balance Seat	P. 18, The Balance Wheel in Detail
Lower Pivot	P. 51, The Conical Pivot and Jewel

# THE ESCAPEMENT

Escape Wheel, Pallets and Balance Staff:

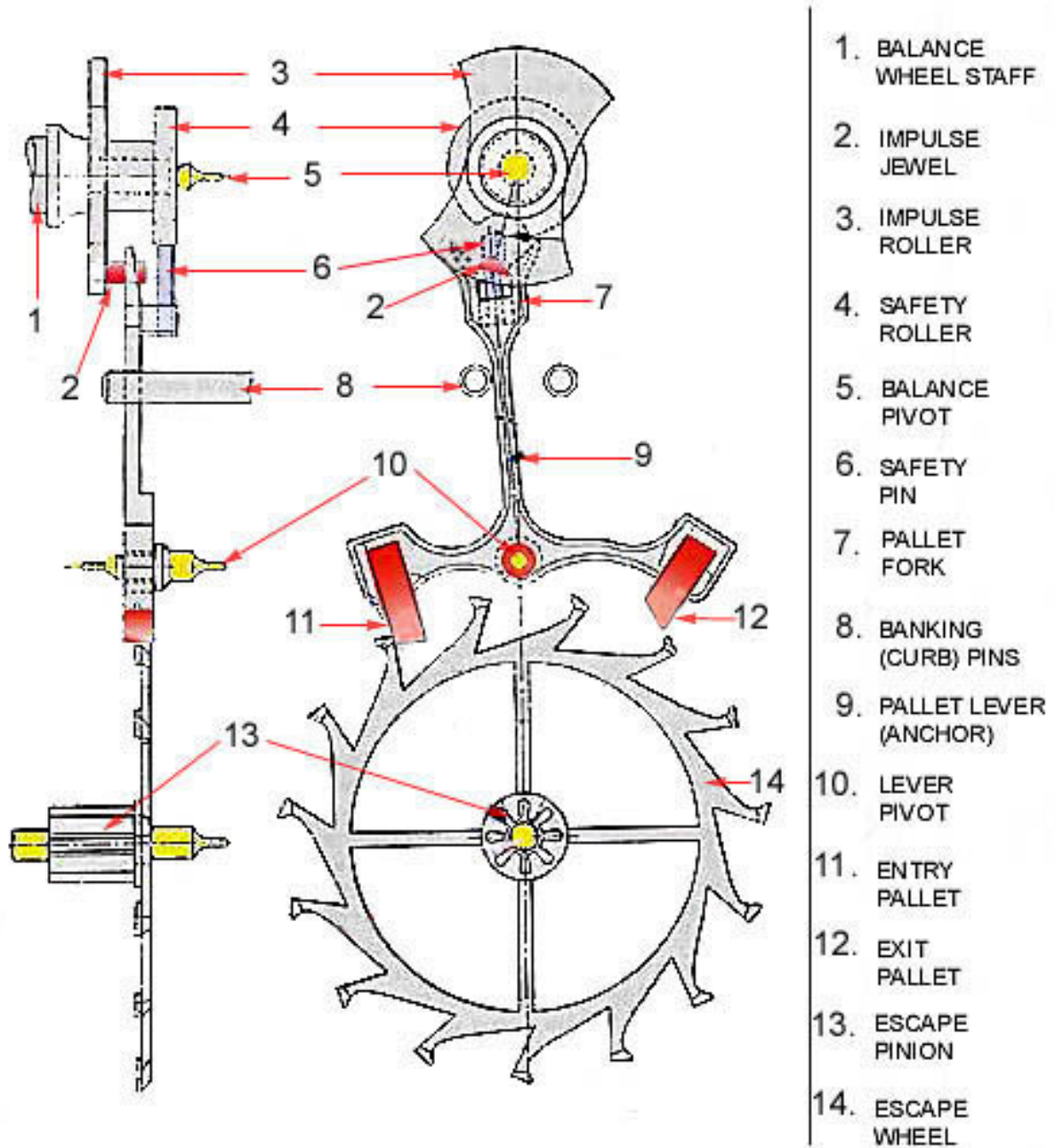

See Page 39 for an illustrated explanation of the escapement's function.

For info about...	See...
Balance Wheel Staff (1)	P. 18, The Balance Wheel in Detail
Impulse Jewel (2)	P. 18, The Balance Wheel in Detail
Impulse Roller (3)	P. 18, The Balance Wheel in Detail
Safety Roller (4)	P. 38, The Escapement: The Pallet Lever Safety

	Pin
Balance Pivot (5)	P. 51, The Conical Pivot and Jewel
Safety Pin (6)	P. 38, The Escapement: The Pallet Lever Safety Pin
Pallet Fork (7)	P. 36, The Escapement: The Pallet Lever
Banking (Curb) Pins (8)	P. 29, The Escapement: The Banking Pins
Pallet Lever (Anchor) (9)	P. 36, The Escapement: The Pallet Lever
Lever Pivot (10)	P. 36, The Escapement: The Pallet Lever
Entry Pallet (11)	P. 30, The Escapement: The Entry Pallet
Exit Pallet (12)	P. 32, The Escapement: The Exit Pallet
Escape Pinion (13)	P. 53, Wheels and Pinions
Escape Wheel (14)	P. 48, THE WHEEL TRAIN



## The Escapement: The Banking Pins

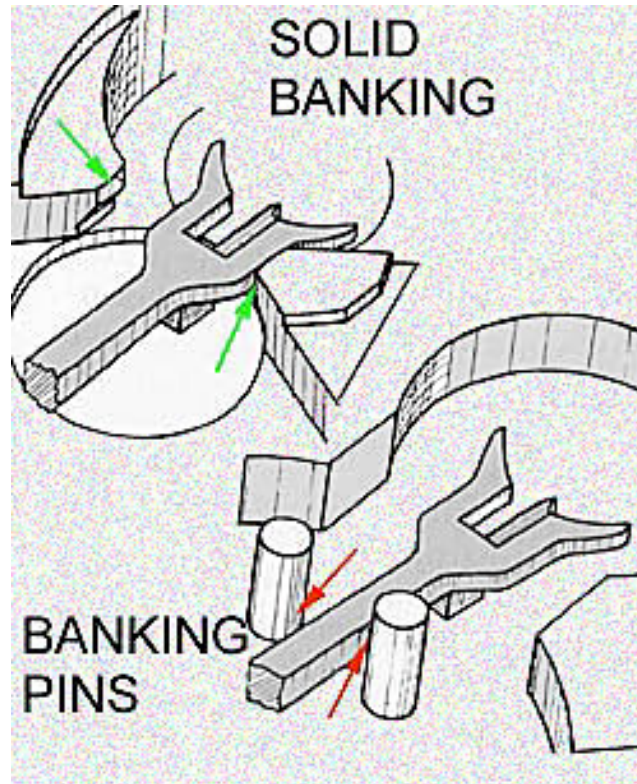

The banking pins—or solid bankings—limit the maximum travel of the pallet lever and thus assure the proper geometry between the pallets and escape wheel teeth.

## The Escapement: The Entry Pallet

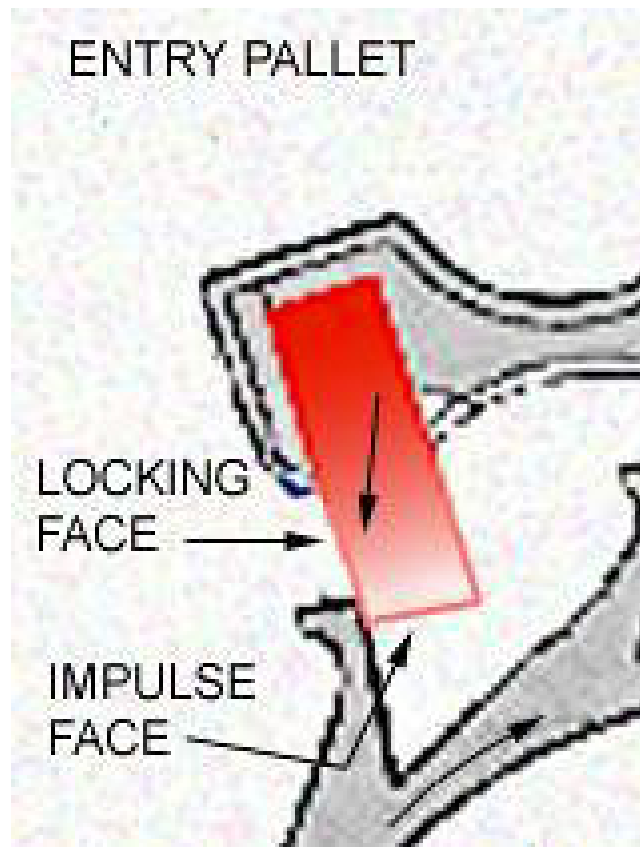

The escape wheel rotates clockwise, as seen from above in this view. The entry pallet is the first to meet an escape wheel tooth. As illustrated, the locking face of the pallet locks against the escape wheel tooth and the pressure of the escape wheel "draws" the pallet down against the tooth (this is called *locking to the draw*, see Page 34, The Escapement: The Exit Pallet During Locking). As the balance impulse jewel comes around, hitting the fork of the escape wheel, the escape tooth is released. The escape wheel tooth rides up the inclined impulse face of the pallet, impelling the pallet away. This is called the impulse (see Page 33, The Escapement: The Exit Pallet During Impulse).

The illustration below shows the entry pallet beginning to lock, the exit pallet just following an impulse (and unlocked).

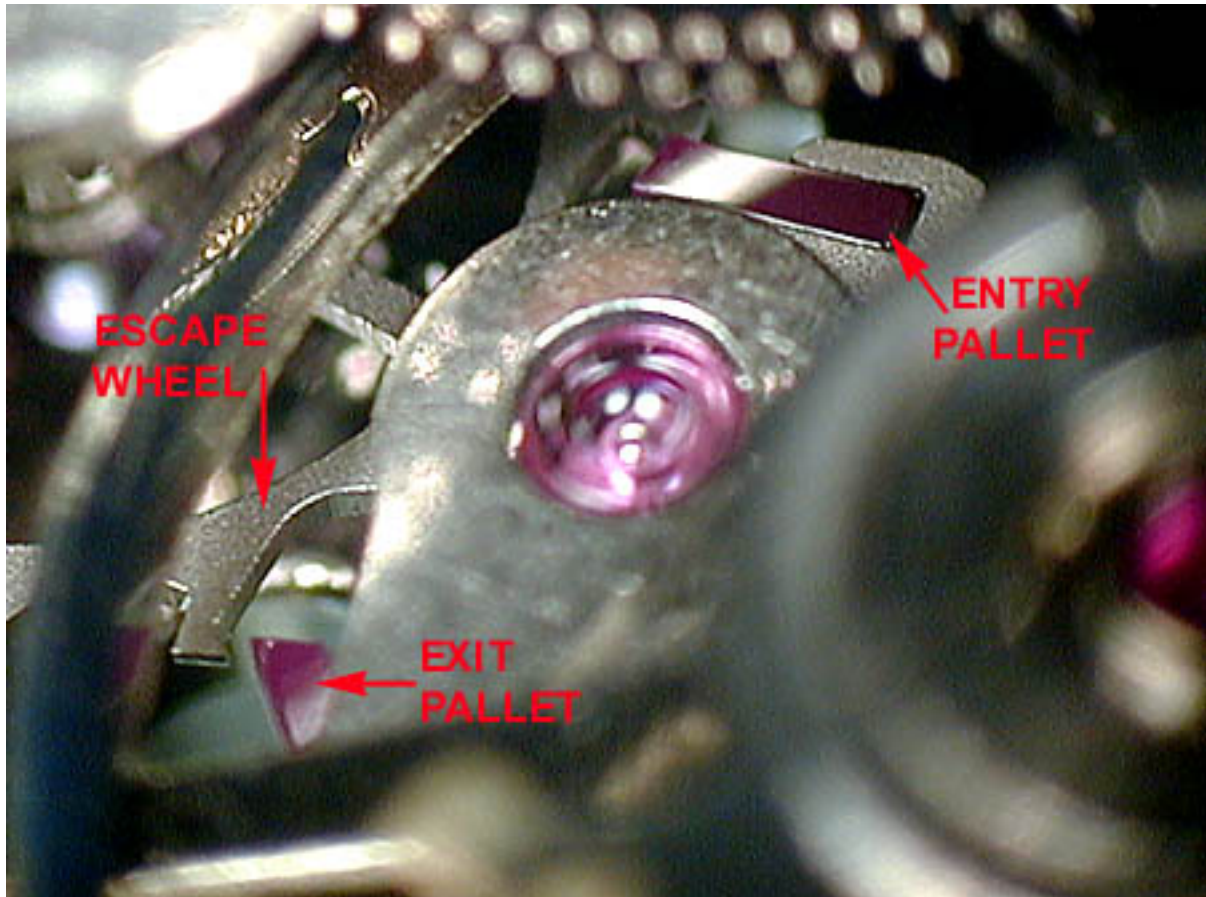

For info about...	See...
Escape Wheel	P. 48, THE WHEEL TRAIN
Entry Pallet	P. 30, The Escapement: The Entry Pallet
Exit Pallet	P. 32, The Escapement: The Exit Pallet

## The Escapement: The Exit Pallet



The escape wheel rotates clockwise, as seen from above in this view. The exit pallet is the last of the two pallets to meet an escape wheel tooth. The locking face of the pallet locks against the escape wheel tooth and the pressure of the escape wheel "draws" the pallet down against the tooth (this is called *locking to the draw*). As the balance impulse jewel comes around, hitting the fork of the escape wheel, the escape tooth is released. As illustrated, the escape wheel tooth rides up the inclined impulse face of the pallet, impelling the pallet away.

See page 33 for a photograph of the exit pallet during *impulse*. See page 34 for a photograph of the exit pallet during *locking*.

## The Escapement: The Exit Pallet During Impulse

As the end of the escape wheel tooth rides along the inclined impulse face of the pallet, the pallet is impelled away (**blue arrow**) and the pallet lever rocks, forcing the opposite pallet into locking the escape wheel.

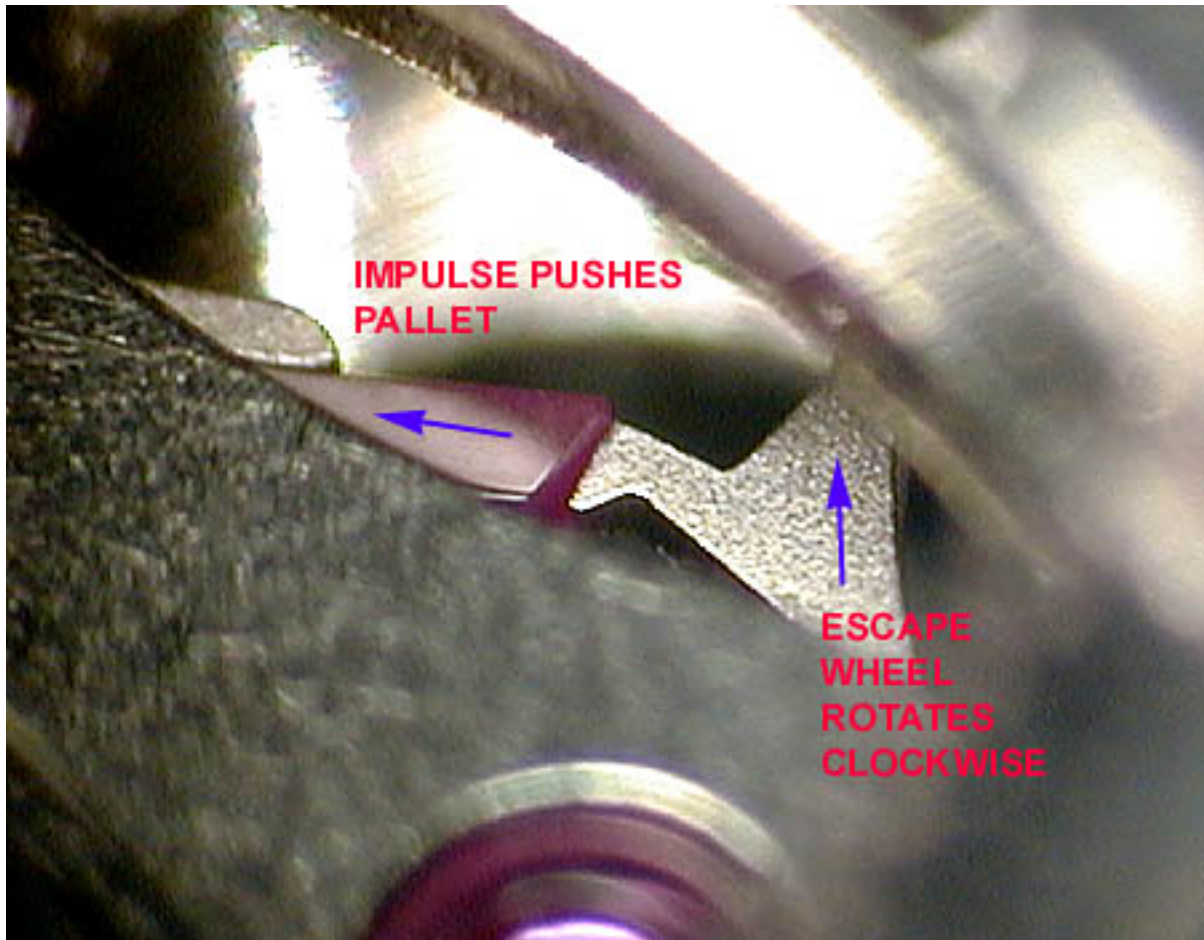

See page 34 for a photograph of the exit pallet during locking.

For info about...	See...
Exit Pallet	P. 32, The Escapement: The Exit Pallet
Escape Wheel	P. 48, THE WHEEL TRAIN
Pallet Lever	P. 36, The Escapement: The Pallet Lever
Exit Pallet During Locking	P. 34, The Escapement: The Exit Pallet During Locking

## The Escapement: The Exit Pallet During Locking

The geometry of the pallets, pallet lever, and escape wheel teeth assure that the pressure of the escape wheel tooth will deepen and maintain the lock of the pallet. The escape wheel pressure is referred to as "draw." Draw keeps the pallet lever firmly against its banking pin.

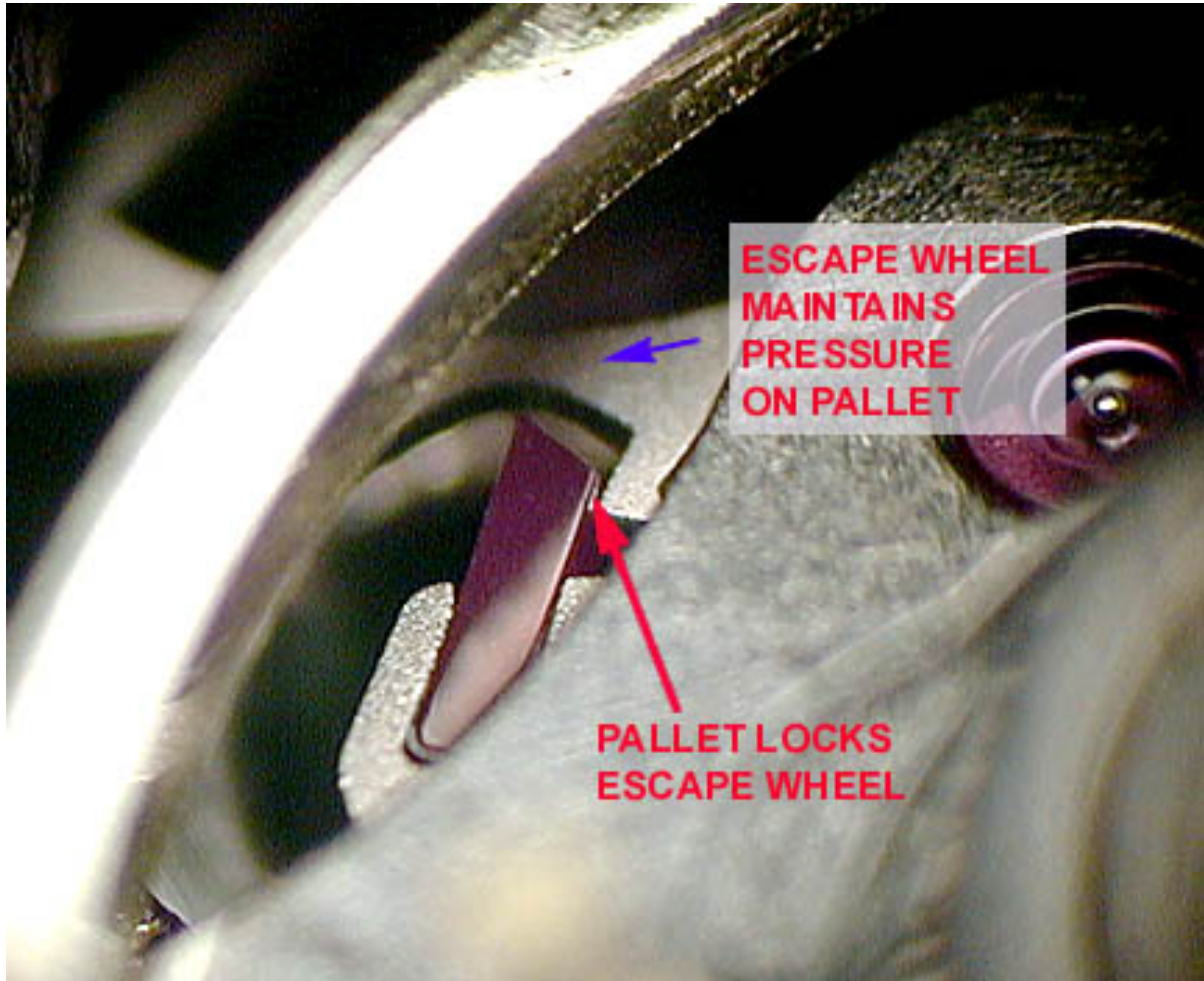

For info about...	See...
Pallet Lever	P. 36, The Escapement: The Pallet Lever
Escape Wheel	P. 48, THE WHEEL TRAIN
Banking Pin	P. 29, The Escapement: The Banking Pins

## The Escapement: The Pallet Lever Geometry

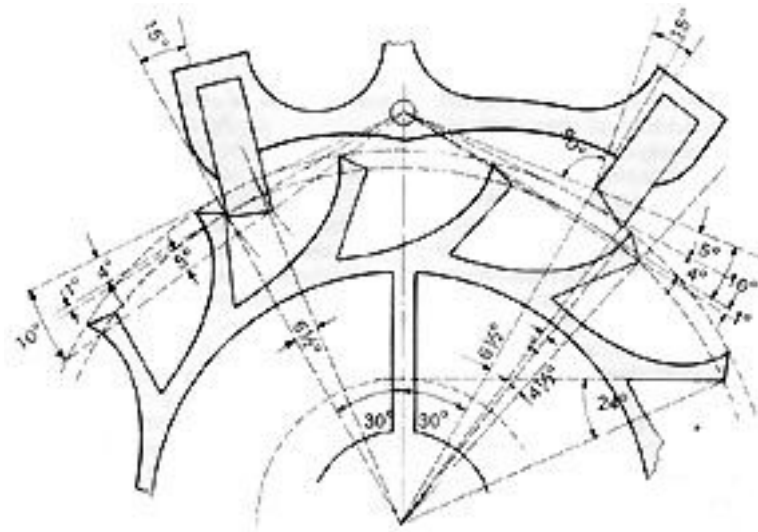

A very precise geometry of the pallet lever (and escape wheel teeth) is required to assure proper locking and impulse of the two pallets on escape wheel teeth. In the 28,800 beats per hour (bph) watch, each pallet executes both operations 14,400 times per hour. The Swiss success with the anchor escapement is attributable to careful attention to this geometry and to precision of manufacture.

## The Escapement: The Pallet Lever

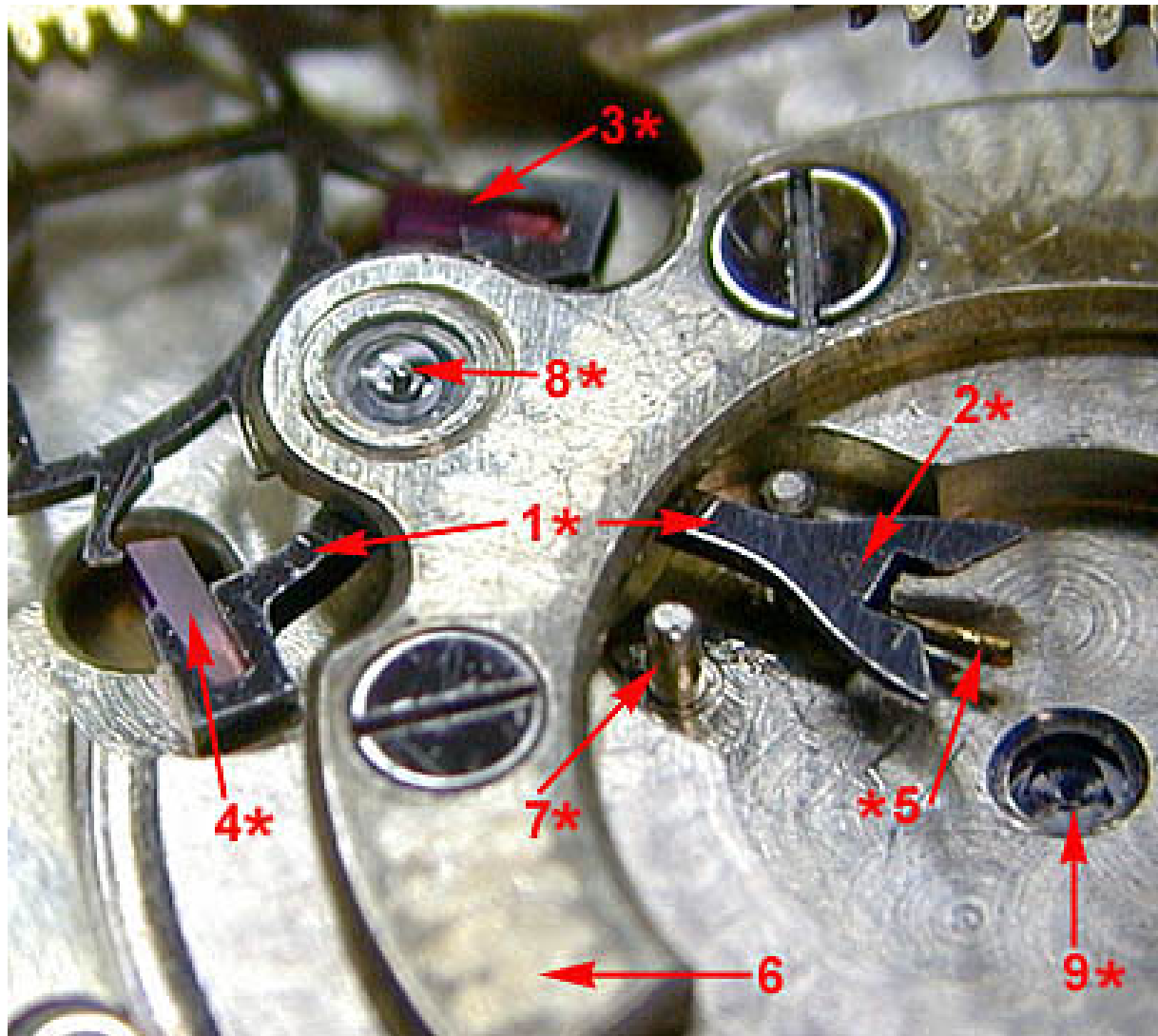

The pallet lever, timed by the balance wheel, alternately stops and releases the escape wheel and is thus responsible for actually carrying out the timing function of the balance. As shown at left, the parts of the pallet are (1) the pallet lever, (2) the pallet fork, (3) the entry pallet, (4) the exit pallet, (5) the safety pin, (6) the pallet lever bridge, (7) the banking pins (two), (8) the upper pallet staff jewel, (9) the lower balance jewel.

For info about...	See...
Pallet Lever (1)	P. 35, The Escapement: The Pallet Lever Geometry
Pallet Fork (2)	P. 38, The Escapement: The Pallet Lever Safety Pin
Entry Pallet (3)	P. 30, The Escapement: The Entry Pallet
Exit Pallet (4)	P. 32, The Escapement: The Exit Pallet
Safety Pin (5)	P. 38, The Escapement: The Pallet Lever Safety Pin



Banking Pins (7)	P. 29, The Escapement: The Banking Pins
Upper Pallet Staff Jewel (8)	P. 52, The Cylindrical Pivot and Jewel
Lower Balance Jewel (9)	P. 24, The Anti-Shock Mechanism

## The Escapement: The Pallet Lever Safety Pin

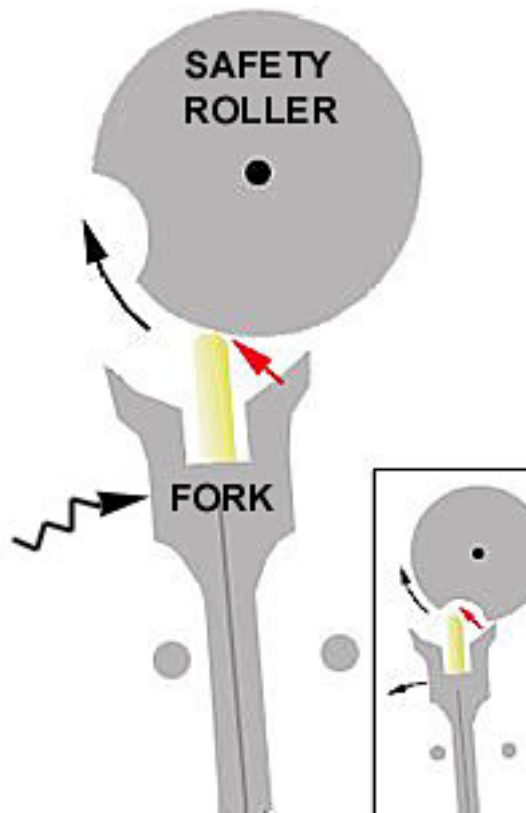

The safety pin (illustrated in **yellow**) allows unlocking of the escape wheel only when the balance wheel is centered (and the impulse jewel is inside the pallet fork). When a physical shock to the watch unlocks a pallet from the escape wheel accidentally, the safety pin hits the safety roller (large illustration, **red** arrow) and prevents movement of the pallet lever. When the pallet is supposed to unlock—with the impulse jewel within the lever fork—the crescent in the safety roller clears the safety pin and allows movement of the lever (small illustration, **red** arrow).

For info about...	See...
Pallet Fork	P. 36, The Escapement: The Pallet Lever
Banking Pins	P. 29, The Escapement: The Banking Pins

## The Escapement: An Illustrated Explanation of Function

In the below sequence of pictures, the escapement is shown moving through two complete *beats*: a balance swing 280 degrees counterclockwise (one beat) and 280 degrees clockwise (second beat). This 280 degree rotation is called the *amplitude* of the balance. In a well-serviced watch, the amplitude should be between approximately 275 and 315 degrees (dial up or down).

If a watch is specified as "21,600 beats per hour," the escapement completes 21,600 "half" (one direction) or 10,800 full swings each hour. While the most common frequencies for contemporary wristwatches are 21,600 and 28,800, some swing as slowly as 18,000 and some as fast as 36,000 beats per hour. Any watch swinging more than 18,000 (the traditional frequency) is considered "fast beat."

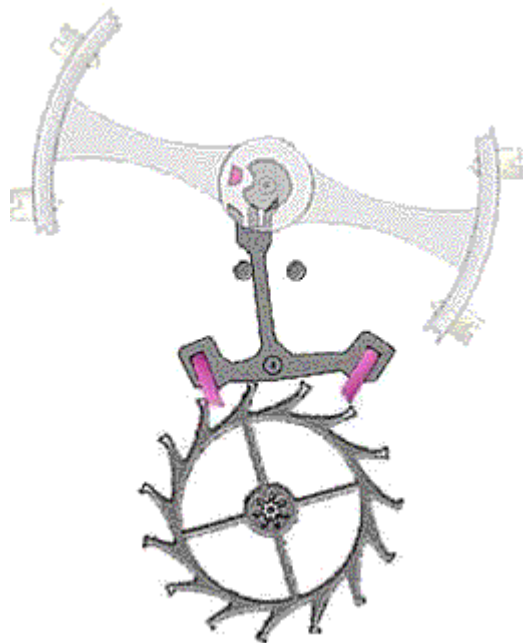

In the illustration, at each of the three critical operations a colored arrow is shown to point to the operation:

### BLUE ARROW

The impulse jewel makes contact with the pallet fork and starts to move the pallet lever off its banking pin.

### GREEN ARROW

The entry pallet releases the escape wheel tooth and the tooth slides up the face of the pallet providing an *impulse* to the balance wheel.

### RED ARROW

The pallet lever rocks to its opposite banking pin and the exit pallet locks the next tooth on the escape wheel.

The same sequence of operations will occur with the opposite-direction swing of the balance and the sequence will then repeat.

The following pages show snapshots of the counter-clockwise and clockwise balance swings.

For info about...	See...
Impulse Jewel	P. 18, The Balance Wheel in Detail
Pallet Fork	P. 36, The Escapement: The Pallet Lever
Banking Pin	P. 29, The Escapement: The Banking Pins
Entry Pallet	P. 30, The Escapement: The Entry Pallet
Escape Wheel	P. 48, THE WHEEL TRAIN
Exit Pallet	P. 32, The Escapement: The Exit Pallet

**Counter-clockwise balance swing:**

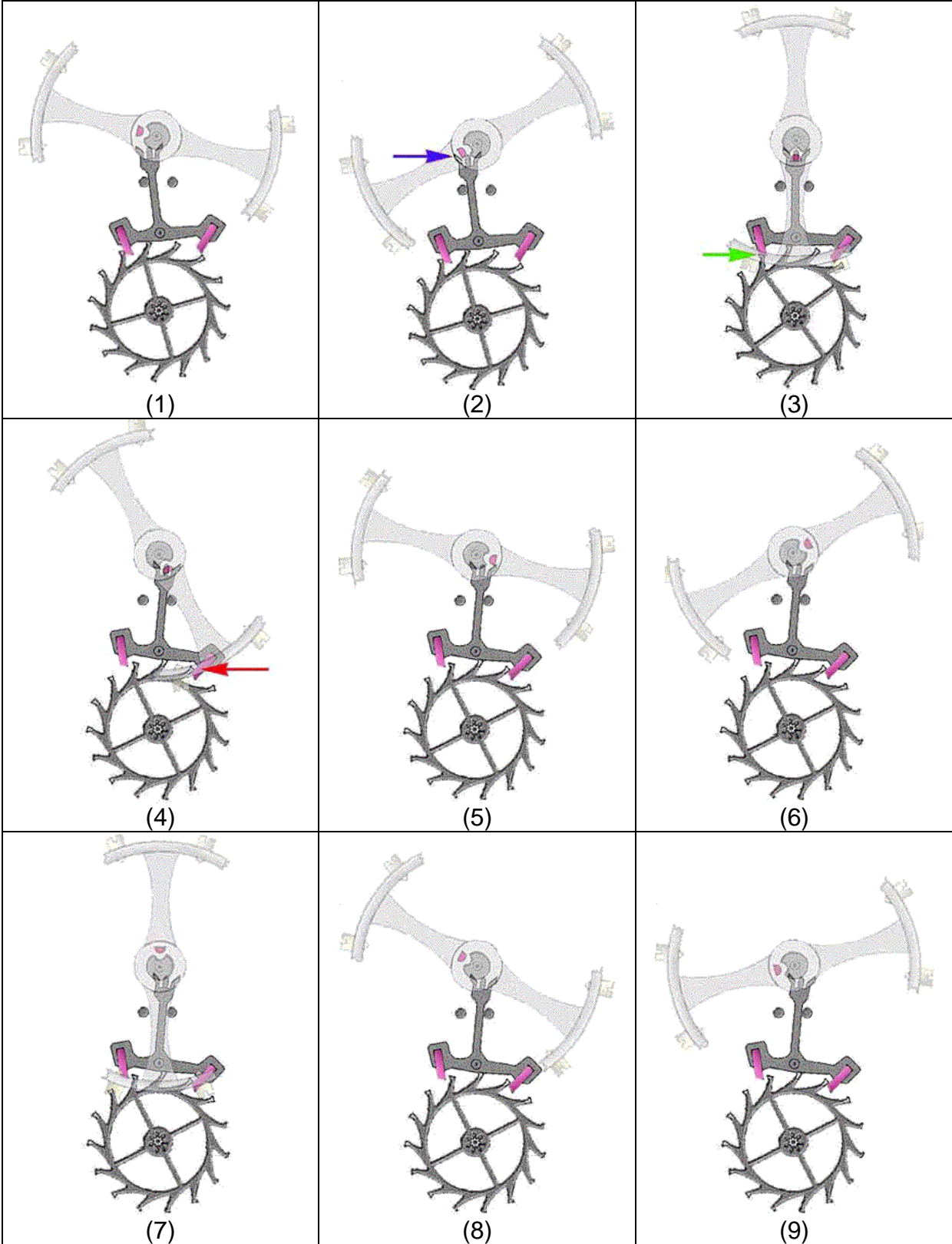

**Clockwise balance swing:**

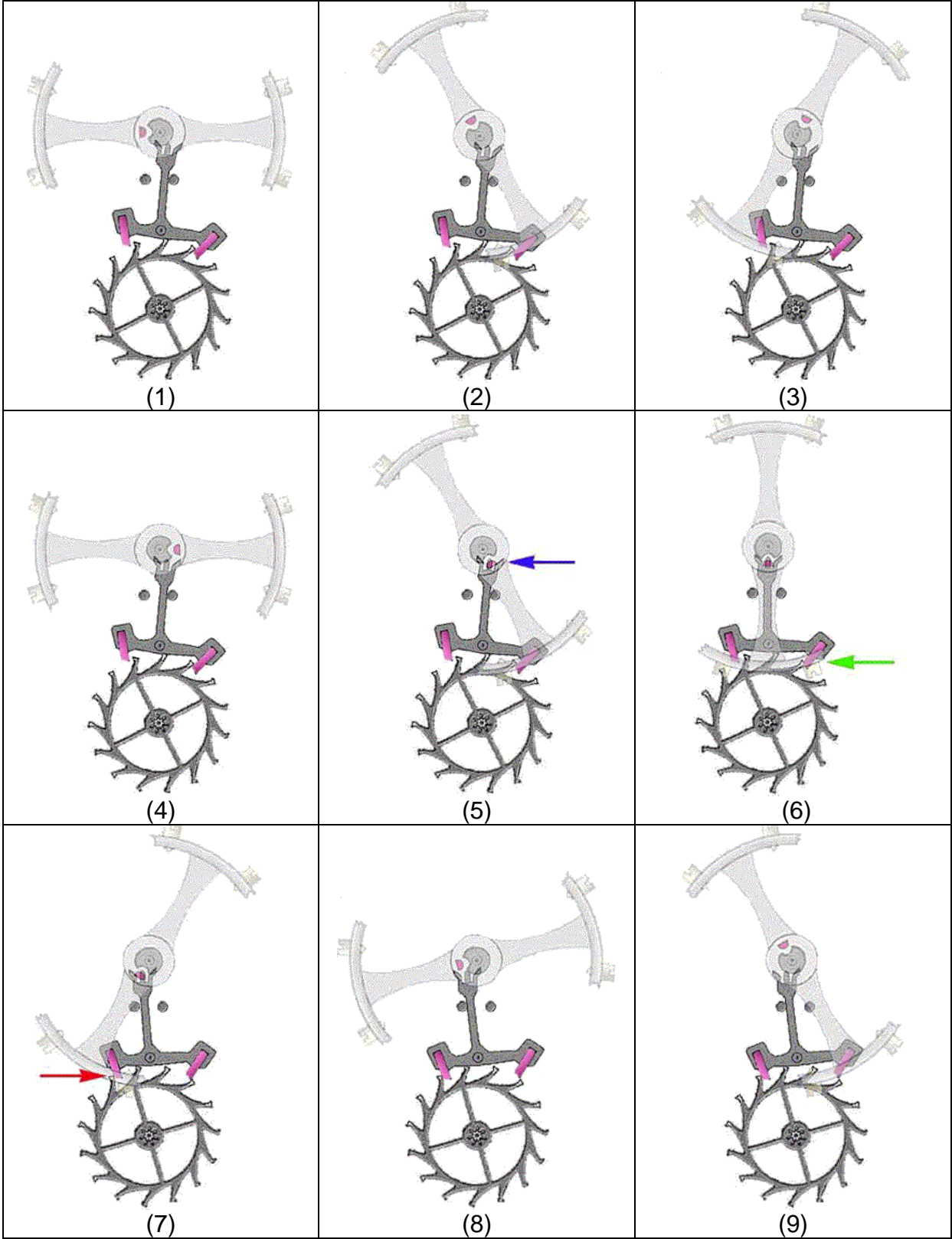

# THE MAINSPRING AND BARREL

The Mainspring, Mainspring Barrel, Barrel Arbor, Ratchet and Crown Wheel:

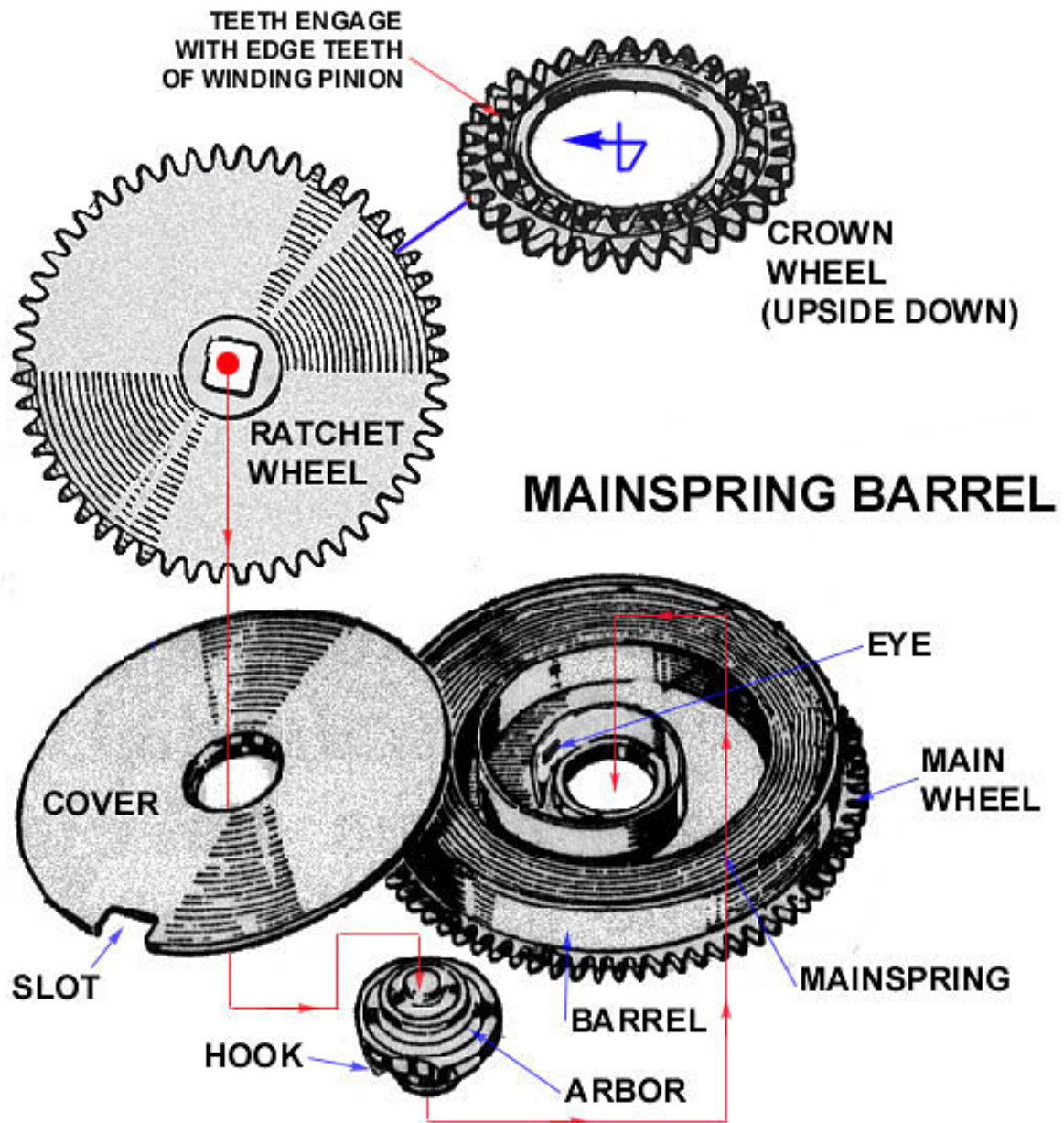

See page 47 to view the mainspring of an automatic winding watch.

For info about...	See...
Crown Wheel	P. 48, THE WHEEL TRAIN
Winding Pinion	P. 5, THE KEYLESS WORKS
Ratchet Wheel	P. 44, The Click
Arbor	P. 44, The Click
Barrel	P. 48, THE WHEEL TRAIN
Mainspring	P. 47, The Mainspring of an Automatic Winding Watch

Main Wheel	P. 48, THE WHEEL TRAIN
Eye	P. 44, The Click

## The Click

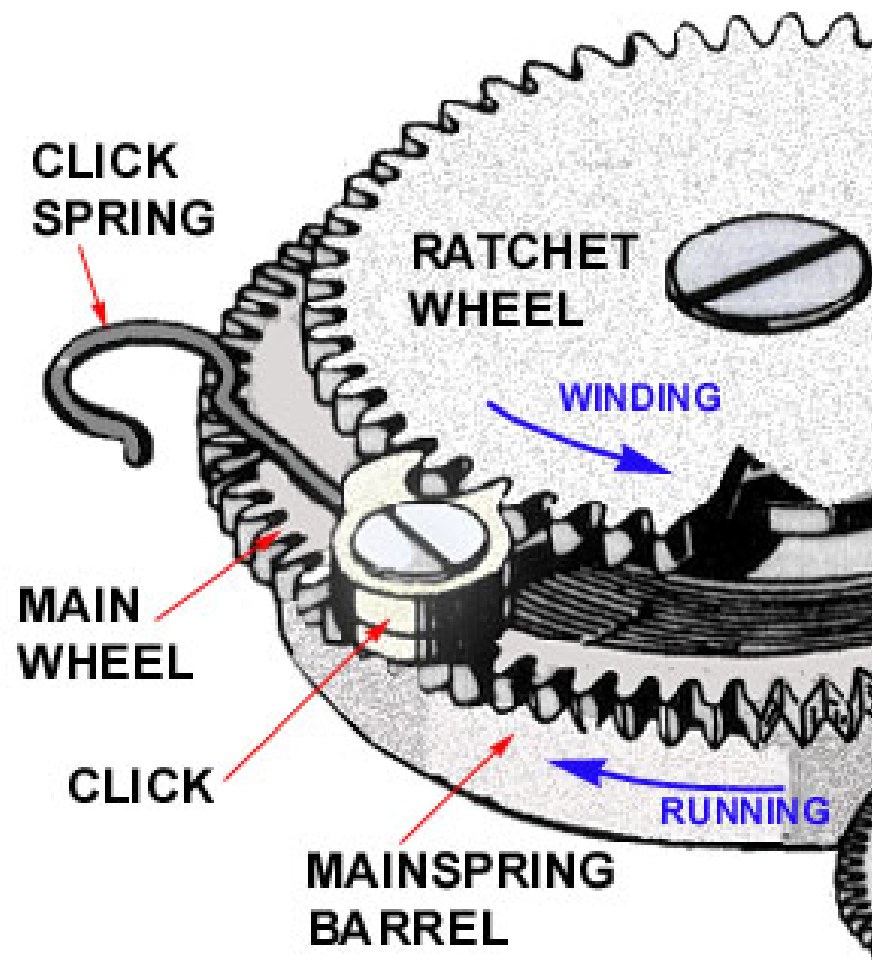

During winding, the mainspring barrel is stationary and the ratchet wheel winds the inner end of the mainspring counter-clockwise around the arbor in the center of the barrel. When the movement is running, the ratchet wheel is stationary and the outer end of the spring rotates the barrel clockwise. The barrel (and integral main wheel) drives the center wheel pinion gear.

While the movement itself prevents the mainspring unwinding from the outer (barrel) end, the ratchet prevents unwinding from the inner (arbor) end. The click is thus designed to prevent the ratchet wheel from rotating clockwise while allowing counter-clockwise movement (for winding).

The click spring maintains tension on the click in the clockwise direction. The very typical two-toothed click design, illustrated, prevents the click from holding the mainspring at absolute full tension. When the crown is released after winding, the click is rocked counter-clockwise (against the click spring) by the large tooth and the small tooth engages and locks the ratchet wheel. This allows the ratchet wheel and arbor to rotate slightly clockwise. This action relieves a bit of tension in the mainspring and prevents excessive tension that might cause the transmission of too much power to the gear train and, thus, knocking of the balance wheel.



See page 46 for a photograph of a typical barrel click mechanism.

<b>For info about...</b>	<b>See...</b>
Ratchet Wheel	P. 42, THE MAINSPRING AND BARREL
Main Wheel	P. 48, THE WHEEL TRAIN
Mainspring Barrel	P. 42, THE MAINSPRING AND BARREL

## The Click and Related Parts

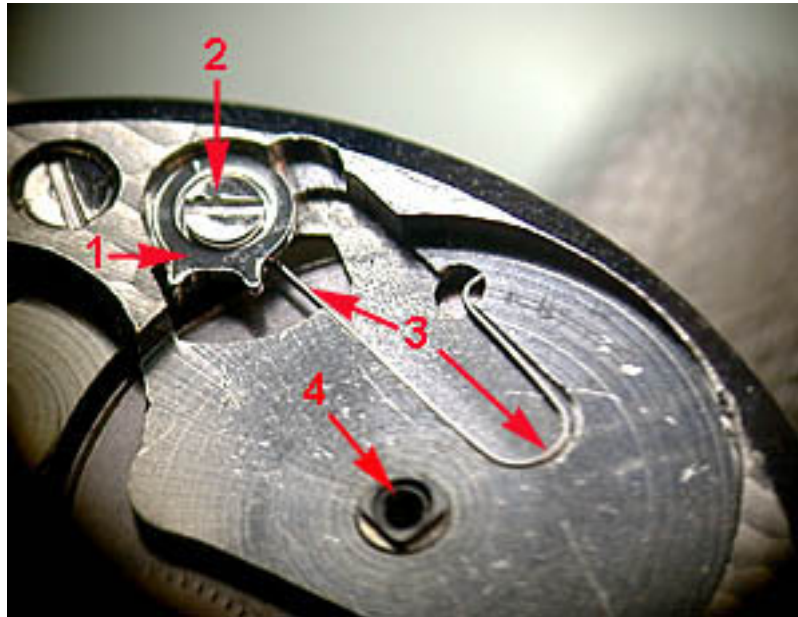

The click (1), click screw (2), click spring (3), and mainspring barrel arbor (4) of a Fontainemelon caliber 97 are illustrated **above**. As illustrated **below**, the end of the click spring acts on a post on the underside of the click (**red arrow**) to keep the click engaged with the ratchet wheel.



For info about...	See...
Click Screw	P. 54, SCREWS
Ratchet Wheel	P. 48, THE WHEEL TRAIN

## The Mainspring of an Automatic Winding Watch

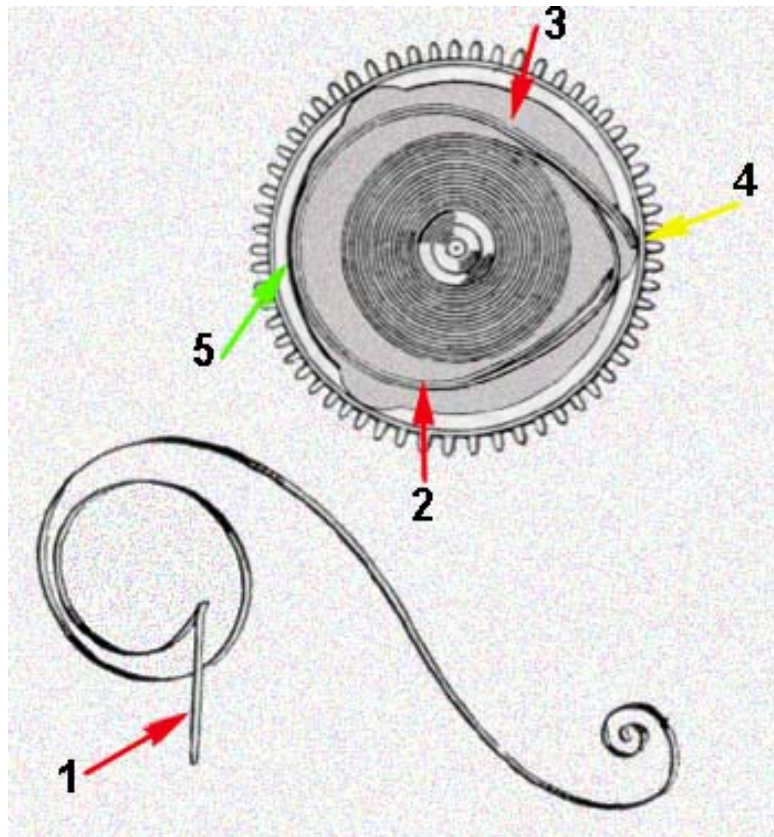

In the automatic winding watch, the mainspring must be designed to prevent overwinding (with continuation of automatic winding) when the spring is fully wound.

This is usually accomplished in contemporary watches with a slipping *bridle* on the outer end of the mainspring as illustrated above (1). The bridle (in the barrel, 2) maintains outward pressure on the outermost coil of the mainspring (3). At less than full wind, the bridle pressure causes the outer tip of the spring to catch in a notch in the barrel wall (4) and maintain its position. As the mainspring reaches full wind, the outer end of the spring jumps out of the notch and releases tension by slipping across the smooth section of the barrel wall (5) until it catches in the next notch.

To see the complete mechanism in an automatic winding watch, see page 7.

# THE WHEEL TRAIN

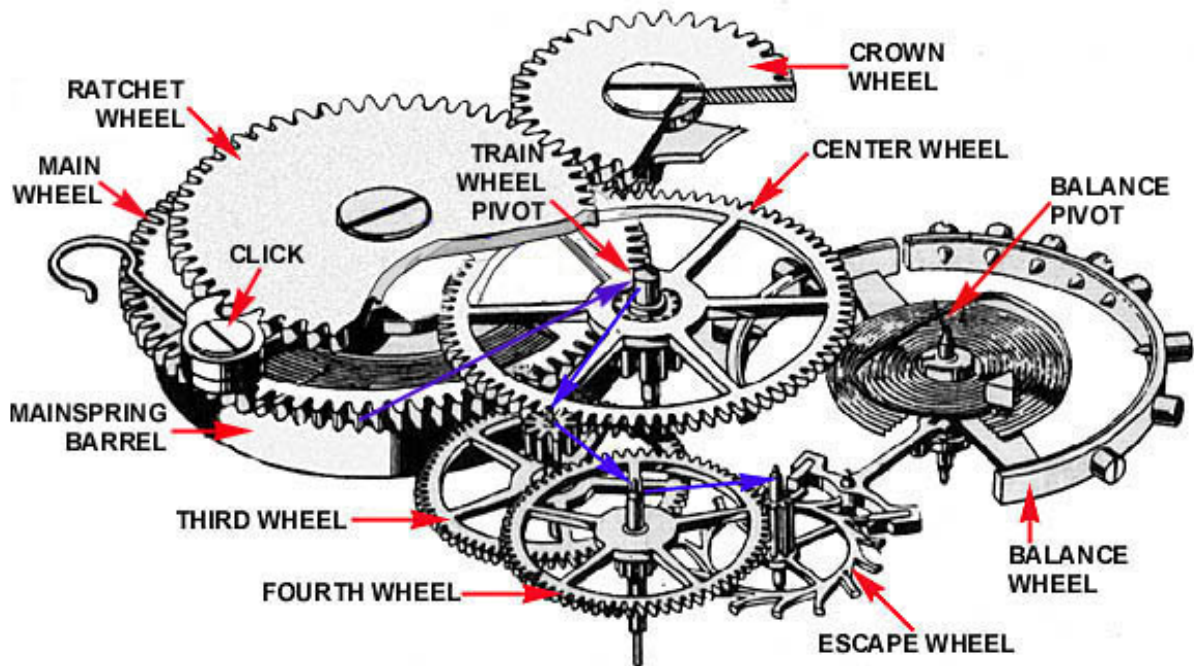

The power flow through the movement is shown by the blue arrows: the main wheel (integral to the mainspring barrel), center wheel, third wheel, fourth wheel, and escape wheel. Each wheel drives the pinion gear of the following wheel.

Many contemporary watches with center seconds use a modified gear train layout to drive the seconds hand in the center of the dial. See page 49 for a photograph of the Fontainemelon caliber 97 center seconds gear train.

For info about...	See...
Ratchet Wheel	P. 42, THE MAINSPRING AND BARREL
Click	P. 44, The Click
Train Wheel Pivot	P. 52, The Cylindrical Pivot and Jewel
Crown Wheel	P. 42, THE MAINSPRING AND BARREL
Center Wheel	P. 53, Wheels and Pinions
Third Wheel	P. 53, Wheels and Pinions
Fourth Wheel	P. 53, Wheels and Pinions
Escape Wheel	P. 53, Wheels and Pinions
Balance Pivot	P. 51, The Conical Pivot and Jewel
Balance Wheel	P. 18, The Balance Wheel in Detail
Pinion Gear	P. 53, Wheels and Pinions

## The Center-Seconds Gear Train: The Fontainemelon Caliber 97



Because the Fontainemelon caliber 97 is a center seconds design and uses a directly driven design, the layout of the wheels varies from the classic wheel train. As illustrated, the center wheel (1) lies at the bottom of the train, in the center of the movement. The center wheel drives the third wheel (2) pinion. The third wheel drives the fourth wheel (3) pinion. And the third wheel drives the escape wheel (4).

For info about...	See...
Center Wheel (1)	P. 53, Wheels and Pinions
Third Wheel (2)	P. 53, Wheels and Pinions
Fourth Wheel (3)	P. 53, Wheels and Pinions
Escape Wheel (4)	P. 53, Wheels and Pinions
Crown Wheel (5)	P. 6, Winding
Click (6)	P. 44, The Click
Ratchet Wheel (7)	P. 42, THE MAINSPRING AND BARREL
Anti-Shock Assembly (8)	P. 24, The Anti-Shock Mechanism
Bridge Screw (9)	P. 54, SCREWS

The fourth wheel, as in all watch movements, makes one full rotation each minute. A movement that has a "directly driven" center seconds, has a seconds hand driven directly by the fourth wheel. (Indirect center seconds usually drives the seconds hand off of the third wheel with appropriate reduction to rotate the seconds hand once per minute.) The unusual layout of the FM-97 allows the fourth wheel to remain in the center of the movement. The long pinion of the fourth wheel (**below left, red arrow**) extends through the hollow pinion of the center wheel (**2, below right**) and carries the seconds hands. The illustration **below right** also shows the center wheel itself (**1**) and the mainspring barrel (**3**).



For info about...	See...
Fourth Wheel (above left, 1)	P. 53, Wheels and Pinions
Center Wheel (above right, 1)	P. 53, Wheels and Pinions
Center Wheel Pinion (above right, 2)	P. 53, Wheels and Pinions
Mainspring Barrel (above right, 3)	P. 42, THE MAINSPRING AND BARREL

## The Conical Pivot and Jewel

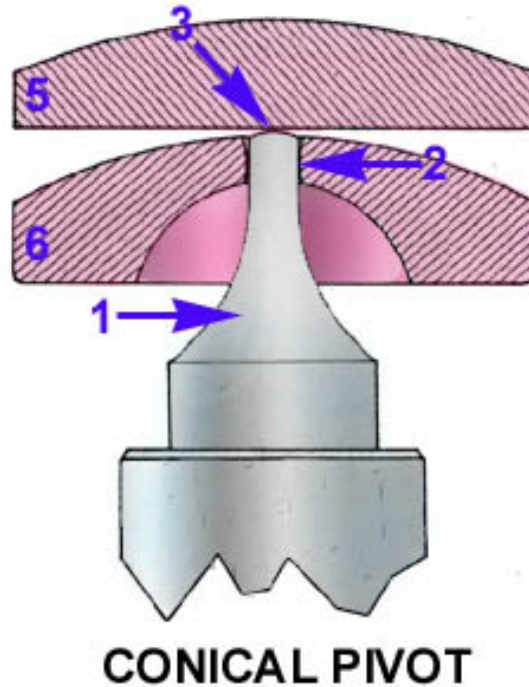

The conical pivot (1) requires two jewels for a bearing, a cap jewel (5) and pierced jewel (6). Unlike the cylindrical pivot, the conical pivot has no "shoulder" and uses the cap jewel to determine end-shake of the wheel pinion (2). This arrangement provides lower friction than the single-jewel cylindrical pivot arrangement. Generally, friction on the conical pivot occurs only at the tip of the pinion on the lower cap jewel (3) or, in a vertical position of the watch (a horizontal position of the pinion) on the thin edges of the holes in the two pierced jewels (6).

The conical pivot is usually used on the balance wheel and, sometimes, on the escape wheel. The balance (and, when provided, escape wheel) anti-shock assembly uses a conical pivot with cap and pierced jewel.

For info about...	See...
Cylindrical Pivot	P. 52, The Cylindrical Pivot and Jewel
Anti-Shock Assembly	P. 24, The Anti-Shock Mechanism

## The Cylindrical Pivot and Jewel

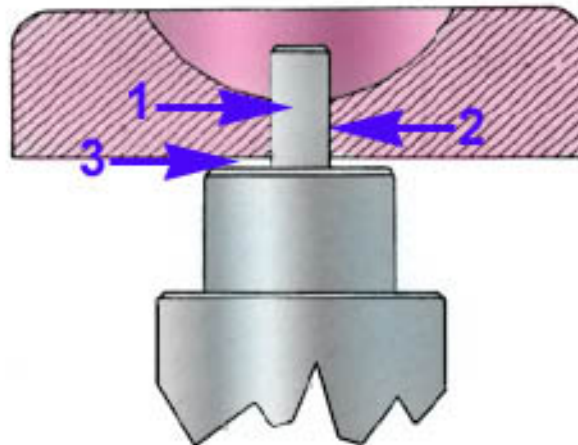

**CYLINDRICAL PIVOT**

The cylindrical pivot (1) has the advantage of simplicity, robustness, and low cost. The friction of the cylindrical pivot is relatively high compared to the two-jewel arrangement used with the conical pivot. This friction results from the relatively thick jewel hole (2) and the pivot shoulder rubbing on the backside of the jewel (3) on the lower pivot (depending on the position of the watch).

The cylindrical pivot is used for the mainspring barrel and gear train of the watch. The balance wheel usually uses a conical pivot, as does the escape wheel in many finer watches.

<b>For info about...</b>	<b>See...</b>
Conical Pivot	P. 51, The Conical Pivot and Jewel
Balance Wheel	P. 18, The Balance Wheel in Detail
Escape Wheel	P. 27, THE ESCAPEMENT



## Wheels and Pinions

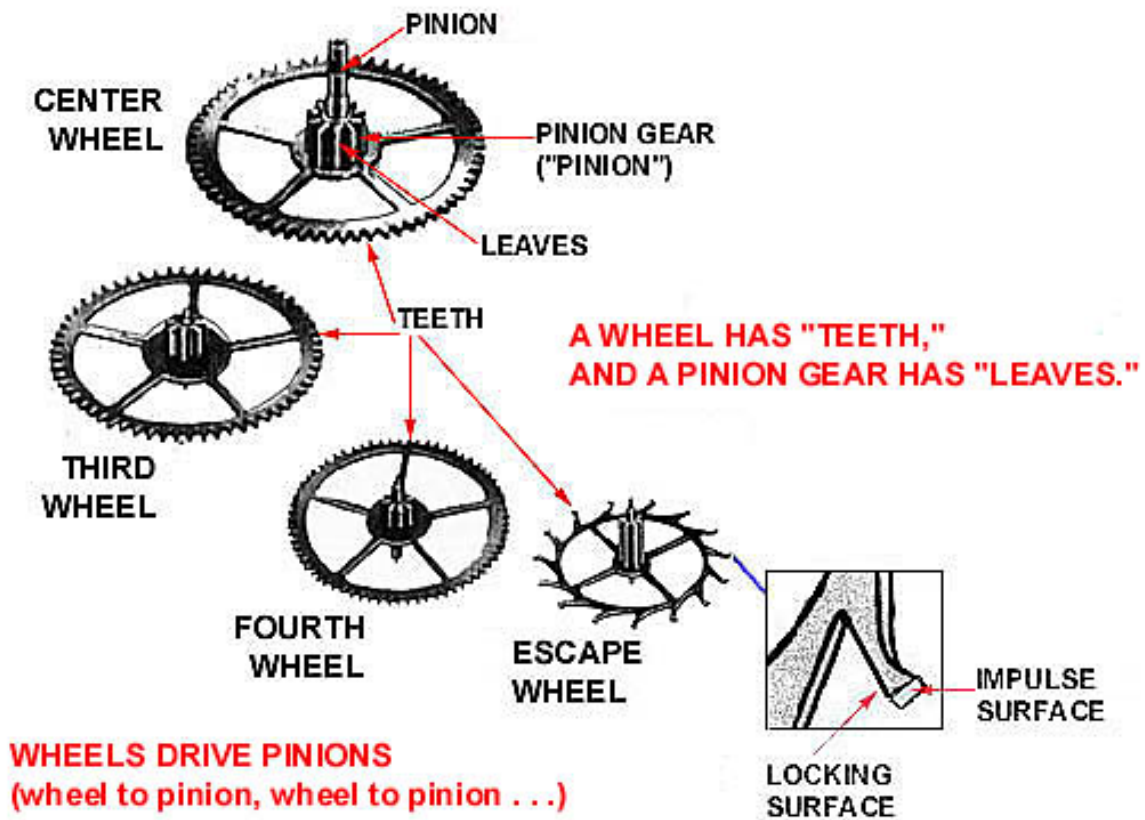

For info about...	See...
Pinion	P. 52, The Cylindrical Pivot and Jewel
Escape Wheel	P. 27, THE ESCAPEMENT
Impulse Surface	P. 32, The Escapement: The Exit Pallet
Locking Surface	P. 30, The Escapement: The Entry Pallet

# SCREWS

The various screws used in the watch:

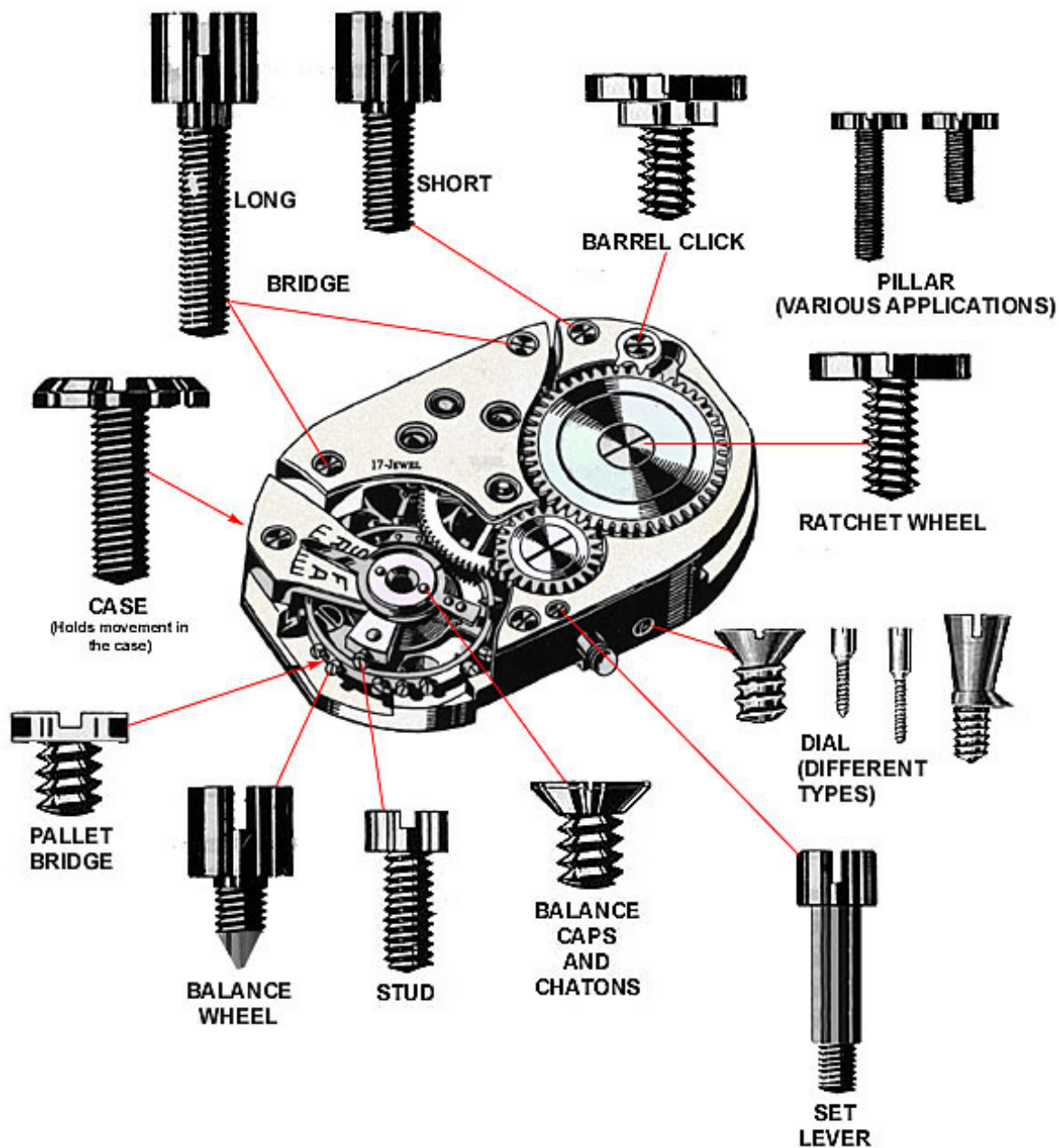

For info about...	See...
Long	P. 48, THE WHEEL TRAIN
Short	P. 48, THE WHEEL TRAIN
Barrel Click	P. 44, The Click
Ratchet Wheel	P. 42, THE MAINSPRING AND BARREL
Set Lever	P. 5, THE KEYLESS WORKS
Balance Caps and Chatons	P. 24, The Anti-Shock Mechanism
Stud	P. 23, The Regulator, Spring Stud, and Anti-Shock

	Mechanism
Balance Wheel	P. 18, The Balance Wheel in Detail
Pallet Bridge	P. 36, The Escapement: The Pallet Lever
Balance Assembly	P. 14, THE BALANCE ASSEMBLY
Spring Stud	P. 17, The Balance Cock and Balance Assembly